

SEADOO®

SP
5879

SPX
5834
5661

GS
5621

GSI
5622

GSX
5624

GTS
5818

GTI
5641

GTX
5642

XP
5662

HX
5882

Shop MANUAL



1997



SEA·DOO®

**SHOP
MANUAL**



Legal deposit:

National Library of Quebec
National Library of Canada

All rights reserved. No parts of this manual may be reproduced in any form without the prior written permission of Bombardier Inc.

©Bombardier Inc. 1996

Printed in Canada

®*Registered trademarks of Bombardier Inc.

Loctite® is a trademark of Loctite Corporation

Snap-on® is a trademark of Snap-on Tools Corporation

Gelcote® is a trademark of Gelcote International Limited

TABLE OF CONTENTS

SECTION	SUB-SECTION	PAGE
SAFETY NOTICE		II
INTRODUCTION		III
01 MAINTENANCE	01 - Table of Contents	01-01-1
	02 - Periodic Inspection Chart	01-02-1
	03 - Flushing and Lubrication	01-03-1
	04 - Water-Flooded Engine	01-04-1
	05 - Storage	01-05-1
02 TROUBLESHOOTING		02-01-1
03 ENGINE	01 - Table of Contents	03-01-1
	02 - Engine Leak Test	03-02-1
	03 - Removal and Installation	03-03-1
	04 - Magneto System	03-04-1
	05 - Top End	03-05-1
	06 - Bottom End	03-06-1
	07 - Rotary Valve	03-07-1
	08 - Exhaust System	03-08-1
04 COOLING SYSTEM	01 - Table of Contents	04-01-1
	02 - Components	04-02-1
	03 - Circuit	04-03-1
05 FUEL SYSTEM	01 - Table of Contents	05-01-1
	02 - Fuel Circuit	05-02-1
	03 - Air Intake	05-03-1
	04 - Carburetors	05-04-1
06 LUBRICATION SYSTEM	01 - Table of Contents	06-01-1
	02 - Oil Injection System	06-02-1
	03 - Oil Injection Pump	06-03-1
07 ELECTRICAL SYSTEM	01 - Table of Contents	07-01-1
	02 - Ignition System	07-02-1
	03 - Charging System	07-03-1
	04 - Starting System	07-04-1
	05 - Instruments and Accessories	07-05-1
	06 - Digitally Encoded Security System	07-06-1
08 PROPULSION SYSTEM	01 - Table of Contents	08-01-1
	02 - Jet Pump	08-02-1
	03 - Drive System	08-03-1
	04 - Reverse System	08-04-1
	05 - Variable Trim System	08-05-1
09 STEERING SYSTEM	01 - Table of Contents	09-01-1
	02 - SP and SPX Models	09-02-1
	03 - GTS Model	09-03-1
	04 - GS, GSI, GSX, GTI and GTX Models	09-04-1
	05 - XP and HX Models	09-05-1
	06 - Alignment	09-06-1
10 SUSPENSION	01 - Table of Contents	10-01-1
	02 - Direct Action Suspension	10-02-1
11 HULL/BODY	01 - Table of Contents	11-01-1
	02 - Adjustment and Repair	11-02-1
12 TECHNICAL DATA	01 - SP and SPX Models	12-01-1
	02 - GS and GSI Models	12-02-1
	03 - GSX Model	12-03-1
	04 - GTS Model	12-04-1
	05 - GTI and GTX Models	12-05-1
	06 - HX and XP Models	12-06-1
13 WIRING DIAGRAMS		13-01-1

SAFETY NOTICE

SAFETY NOTICE

This manual was primarily published to be used by watercraft technicians trained by the manufacturer who are already familiar with all service and maintenance procedures relating to Bombardier made Sea-Doo watercraft.

Please note that the instructions will apply only if proper hand tools and special service tools are used.

It is understood that this manual may be translated into another language. In the event of any discrepancy, the English version shall prevail.

The content depicts parts and/or procedures applicable to the particular product at its time of manufacture. It does not include dealer modifications, whether authorized or not by Bombardier, after manufacturing the product.

The use of Bombardier parts is most strongly recommended when considering replacement of any component. Dealer and / or distributor assistance should be sought in case of doubt.

Torque wrench tightening specifications must be strictly adhered to. Locking devices (ex.: locking disk, lock nut) must be installed or replaced with new ones, where specified. If the efficiency of a locking device is impaired, it must be renewed.

This manual emphasizes particular information denoted by the wording and symbols;

 WARNING

Identifies an instruction which, if not followed, could cause serious personal injury including possibility of death.

 CAUTION

Denotes an instruction which, if not followed, could severely damage watercraft components.

NOTE: Indicates supplementary information needed to fully complete an instruction.

Although the mere reading of such information does not eliminate the hazard, your understanding of the information will promote its correct use. Always use common shop safety practice.

This information relates to the preparation and use of Bombardier watercraft and has been utilized safely and effectively by Bombardier Inc. However, Bombardier Inc. disclaims liability for all damages and/or injuries resulting from the improper use of the contents. We strongly recommend that any services be carried out and/or verified by a highly skilled professional technician. It is understood that certain modifications may render use of the watercraft illegal under existing federal, provincial and state regulations.

1997 BOMBARDIER WATERCRAFT SHOP MANUAL

INTRODUCTION

This *Shop Manual* covers BOMBARDIER made SEA-DOO® watercraft models SP 5879, SPX 5834/5661, XP 5662, GS 5621, GSI 5622, GSX 5624, GTS 5818, GTI 5641, GTX 5642 and HX 5882.

HULL IDENTIFICATION NUMBER (H.I.N.)

SP, SPX, GTS and HX Models

It is located at right rear side of hull.

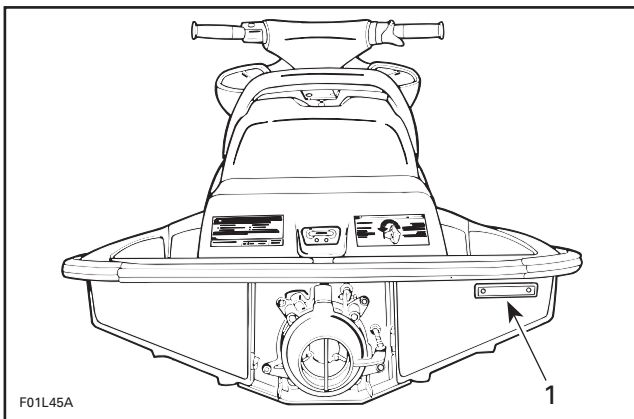

1. Hull Identification Number (H.I.N.)

XP, GS, GSI, GSX, GTI and GTX Models

It is located on floorboard at the rear of the watercraft.

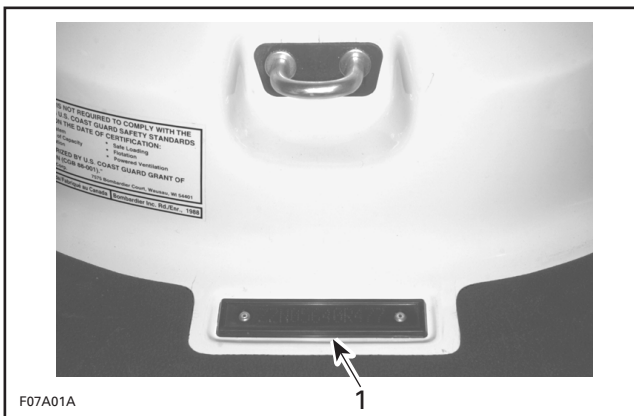

1. Hull Identification Number (H.I.N.)

All Models

The Hull Identification Number is composed of 9 digits:

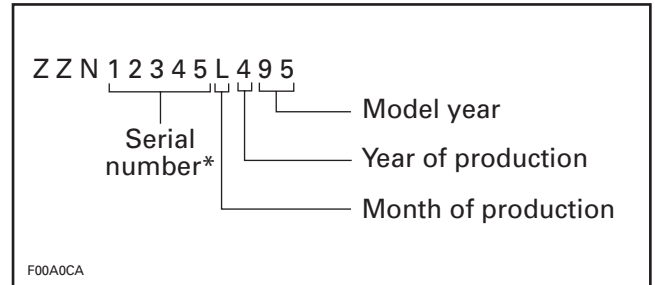

*A letter may also be used as a digit.

ENGINE IDENTIFICATION NUMBER (H.I.N.)

717 Engines

The Engine Identification Number is located on the upper side of the magneto housing.

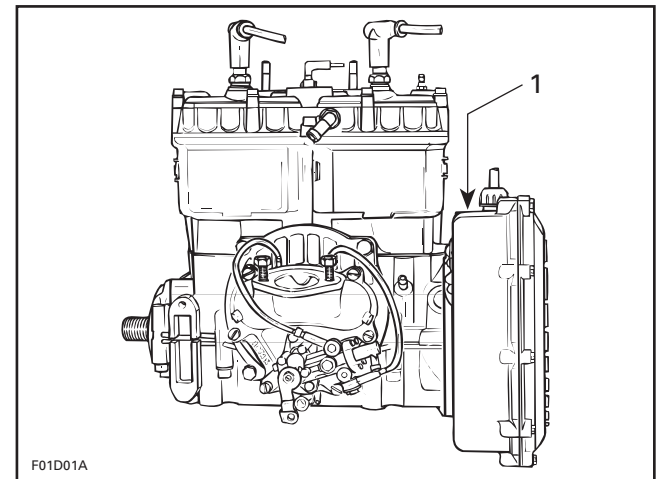

TYPICAL

1. Engine Identification Number (E.I.N.)

1997 BOMBARDIER WATERCRAFT SHOP MANUAL

787 Engine

The Engine Identification Number is located on the crankcase on PTO side.

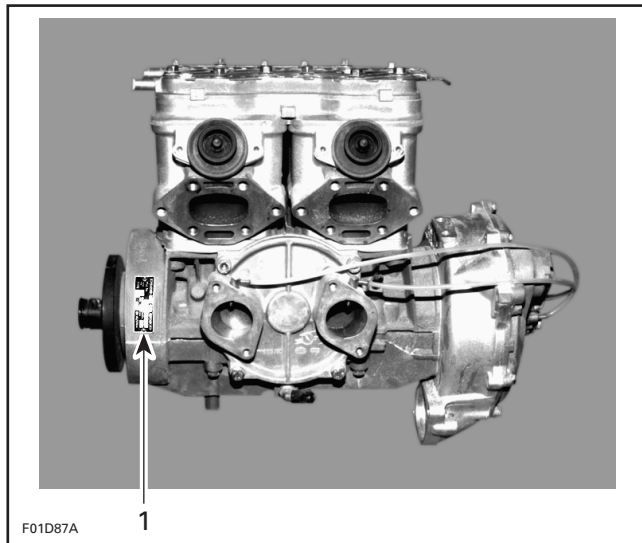

1. Engine Identification Number (E.I.N.)

ARRANGEMENT OF THIS MANUAL

The manual is divided into 13 major sections:

- 01 MAINTENANCE
- 02 TROUBLESHOOTING
- 03 ENGINE
- 04 COOLING SYSTEM
- 05 FUEL SYSTEM
- 06 LUBRICATION SYSTEM
- 07 ELECTRICAL SYSTEM
- 08 PROPULSION SYSTEM
- 09 STEERING SYSTEM
- 10 SUSPENSION
- 11 HULL/BODY
- 12 TECHNICAL DATA
- 13 WIRING DIAGRAMS

Several sections are divided in various sub-sections. There is a table of contents at the beginning of many sections.

TYPICAL PAGE

Page heading indicates section and sub-section detailed.

Sub-section title indicates beginning of the sub-section.

MAGNETO SYSTEM

717 Engine

Italic sub-title above exploded view indicate pertaining models.

Section 03 ENGINE
Sub-Section 04 (MAGNETO SYSTEM)

MAGNETO SYSTEM

717 Engine

Drop represents a liquid product to be applied to a surface. In this case Loctite 242 to screw threads.

Explored view assists you in identifying parts and related positions.

Bold face number indicates special procedure concerning this part.

Illustration number for publishing process.

Dotted box contains parts of a particular model or an exploded view.

Tightening torque nearby fastener. In this case, nut must be torqued to 145 N·m (107 lbf·ft).

▼ CAUTION

Pay attention to torque specifications. Some of these are in **lbf·in** instead of **lbf·ft**. Use appropriate torque wrench.

Page numbering system:
03: ENGINE section
04: MAGNETO SYSTEM sub-section
1: First page of this sub-section

F01A09S

TYPICAL PAGE

Sub-title with part number(s) from exploded view followed by part name(s).

Section 06 FUEL SYSTEM Sub-Section 03 (CARBURETORS)

Title indicates main procedure to be carried-out.

CARBURETOR REMOVAL

To remove carburetors from engine, proceed as follows:
Remove air vent tube support.
Unlock retaining slides holding air intake silencer base.
Remove air intake silencer base from watercraft.
Remove screws holding flame arrester base support to cylinder head cover.
Unscrew base retaining screws then remove base from carburetors and move to front of watercraft.
Turn the valve to OFF position.

Service tool to be used to perform a certain procedure.

NOTE: For fuel line removal, use pliers (P/N 295 000 054).

Disconnect pulse line from fuel pump.
Disconnect fuel supply line from fuel pump.
Disconnect fuel return line.
Disconnect oil injection pump cable, throttle cable and choke cable.

Title in italic indicates a particular procedure concerning a model.

XP Model Only

Remove screws no. 6 and lock washers no. 7 retaining carburetors.

Sub-sub-title in this case indicates that particular procedure for XP is finished, so from this point, all others models are concerned.

All Others Models

Remove 4 bolts no. 8 and lock washers no. 12 from rotary valve cover then move carburetors and rotary valve cover on top of engine.

NOTE: When removing rotary valve cover, pay attention that the rotary valve stay in place, otherwise it must be timed.

Remove carburetors from intake manifold.
Disconnect fuel bypass line between carburetors (twin carburetors).
Remove carburetor(s) from rotary valve cover.

DISASSEMBLY AND INSPECTION

Inspect parts for corrosion damage (shaft, butterfly, spring, etc., check valve housing, etc.).

3, Diaphragm

PUMP DIAPHRAGM LEAK TEST

Using a suitable pump gauge tester, perform the following test proceeding as follows:

- Install pump gauge tester (P/N 295 000 083) on pulse nipple.
- Pump tester until it reaches 28 kPa (4 PSI).

Sub-sub-title in capital indicates a particular testing, adjustment or repair procedure.

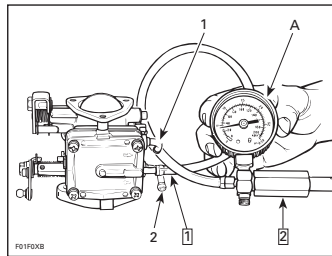

Illustration always follows text it is pertained to.

TYPICAL
Step 1: Install pump gauge tester to pulse nipple
Step 2: Pump tester until it reaches the desired pressure
1. Fuel outlet nipple
2. Fuel inlet nipple
A. 28 kPa (4 PSI)

"TYPICAL" mention indicates a general view which does not represent full detail.

Diaphragm must stand pressure for 10 seconds. If pressure drops, replace diaphragm.

Numbers in a frame are used to give a sequence to be performed.

Letters are used for any measures.

Bold numbers in the text refer to the parts shown in the exploded view at the beginning of the sub-section.

Numbers are used for description of components.

06-03-4

GENERAL INFORMATION

The use of RIGHT and LEFT indications in the text, always refers to driving position (when sitting on watercraft).

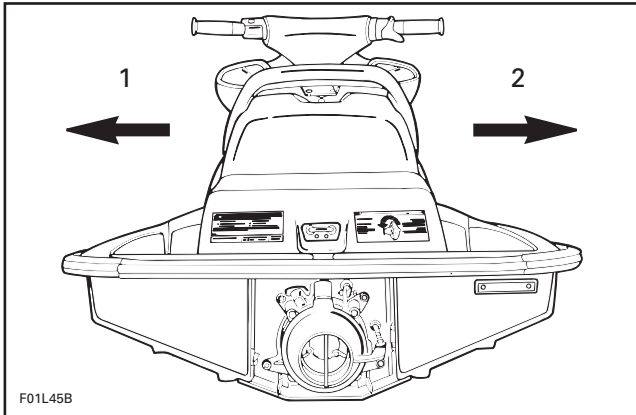

1. Left (port)
2. Right (starboard)

The information and component/system descriptions contained in this manual are correct at time of publication. Bombardier Inc. however, maintains a policy of continuous improvement of its products without imposing upon itself any obligation to install them on products previously manufactured.

Bombardier Inc. reserves the right at any time to discontinue or change specifications, designs, features, models or equipment without incurring obligation.

This *Shop Manual* uses technical terms which may be different from the ones of the *Parts Catalogs*.

When ordering parts always refer to the specific model *Parts Catalogs*.

ILLUSTRATIONS AND PROCEDURES

The illustrations show the typical construction of the different assemblies and, in all cases, may not reproduce the full detail or exact shape of the parts shown, however, they represent parts which have the same or a similar function.

▼ CAUTION

These watercraft are designed with parts dimensioned in both the metric and the imperial systems. When replacing fasteners, make sure to use only those recommended by Bombardier.

As many of the procedures in this manual are interrelated, we suggest, that before undertaking any task, you read and thoroughly understand the entire section or sub-section in which the procedure is contained.

A number of procedures throughout the book require the use of special tools. Before undertaking any procedure, be sure that you have on hand all the tools required, or approved equivalents.

Technical Publications
Bombardier Inc.
Valcourt (Quebec), Canada

TABLE OF CONTENTS

PERIODIC INSPECTION CHART	01-02-1
<hr/>	
FLUSHING AND LUBRICATION	01-03-1
GENERAL	01-03-1
PROCEDURE	01-03-1
<hr/>	
WATER-FLOODED ENGINE	01-04-1
GENERAL	01-04-1
PROCEDURE	01-04-1
<hr/>	
STORAGE	01-05-1

PERIODIC INSPECTION CHART

NOTE: Servicing period is given in hours. Shaded area shows the maintenance frequency.

DESCRIPTION	FREQUENCY			
	Every 10 hours	Every 25 hours	Every 50 hours	Every 100 hours or seasonally
Lubrication/corrosion protection of metallic components	①			
Engine ignition timing				
Spark plug replacement				
Throttle/choke cables, inspection/lubrication	①			
Flame arrester inspection				
Carburetor adjustment including choke/throttle cable adjustments and linkage				
RAVE valve cleaning (787 engine)				
Water flow regulator valve inspection (787 engine)				
Oil injection pump adjustment				
Fuel filter and oil filter inspection				
Fuel filter and oil filter replacement				
Engine head bolts, retorque				
Steering system inspection				
Reverse system/reverse cable adjustment (if applicable)				
Variable trim system (if applicable)				
Fastener tightening (flame arrester support, carburetor(s), engine mount, exhaust system, etc).				
Muffler, battery and reservoir fastening devices				
Fuel/oil lines, check valve and hose inspection, fuel system pressurization				
Fuel/vent line pressure relief valve inspection				
Inspect/clean engine drain hose	①			
Water tank trap drain inspection (GTS)				
Bailer pick up inspection				
Battery condition				
Electrical connections (starter, battery, etc.)				
Monitoring beeper				
Impeller shaft reservoir oil level/oil condition				Replace
Impeller condition and impeller/wear ring clearance		②		
Drive shaft boot/spline condition (both ends)		②		
PTO flywheel and mid bearing (HX/XP models only) lubrication				
Water intake grate condition		②		
Hull condition				
Cooling system flushing	③			

① Every 10 hours in salt water use.

② These items have to be initially checked after 25 hours. Thereafter, servicing to be made as specified in this chart.

③ Daily flushing in salt water or foul water use.

FLUSHING AND LUBRICATION

GENERAL

Flushing the cooling system with fresh water is essential to neutralize corroding effects of salt or other chemical products present in water. It will help to clean up sand, salt, shells or other particles in water jackets (engine, exhaust manifold, tuned pipe) and/or hoses.

Flushing and engine lubrication should be performed when the watercraft is not expected to be used further the same day or when the watercraft is stored for any extended time.

▼ CAUTION
Failure to flush cooling system, when necessary, will severely damage engine and/or exhaust system. Never flush a hot engine. Make sure engine operates during entire procedure.

PROCEDURE

◆ WARNING
Perform this operation in a well ventilated area. Do not touch any electrical parts or jet pump area when engine is running.

Clean jet pump by spraying water in its inlet and outlet and then spray BOMBARDIER LUBE lubricant.

◆ WARNING
Always remove safety lanyard cap from switch to prevent accidental engine starting before cleaning the jet pump area. Engine must not be running for this operation.

SP, SPX and GTS Models

Remove seat to allow access of cooling system.

XP Model

Remove rear access cover.

SP, SPX, GTS and XP Models

Remove dust cap from fitting spigot and attach coupler hose (P/N 295 500 258). Make sure coupler hose is properly locked to fitting spigot.

Install a hose pincher on water outlet hose.

▼ CAUTION
This prevents water from exiting through outlet socket. Remove hose pincher after flushing operation.

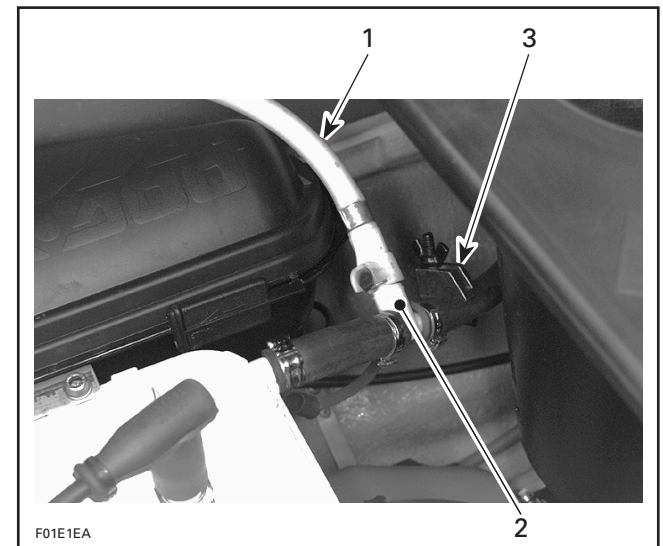

TYPICAL

1. Coupler hose
2. Fitting spigot
3. Hose pincher

Attach other end of coupler hose to a garden hose.

▼ CAUTION
Do not open water tap yet.

GS Series, GTI and GTX Models

Connect a garden hose to the water outlet located at the rear of the watercraft.

Section 01 MAINTENANCE

Sub-Section 03 (FLUSHING AND LUBRICATION)

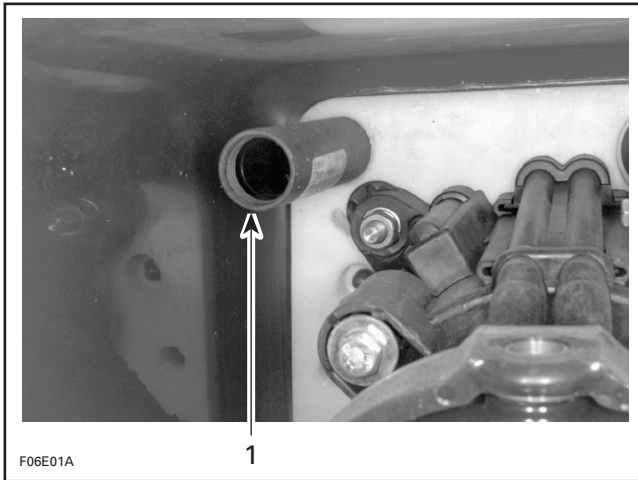

F06E01A

1

1. Water outlet

NOTE: A quick hose connector can be used to ease garden hose installation.

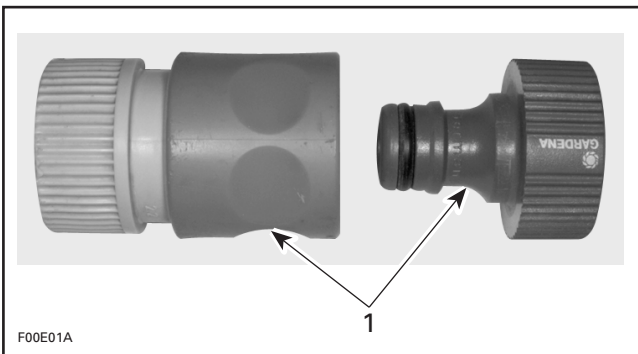

F00E01A

1

1. Quick hose connector

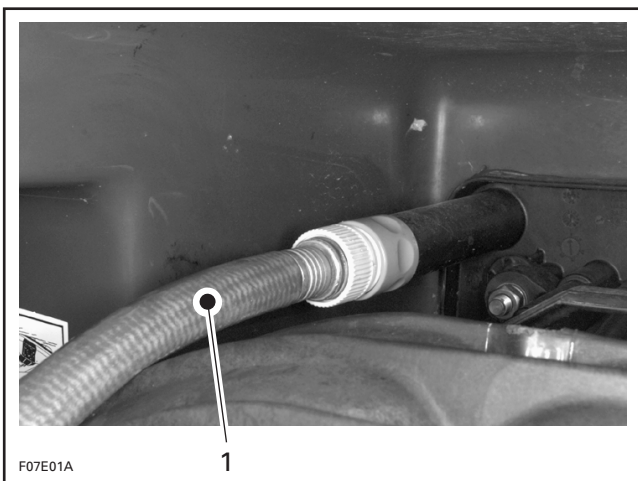

F07E01A

1

1. Garden hose installed

All Models

Start the engine then immediately open the water tap.

▼ CAUTION

Always start the engine before opening the water tap. Open water tap immediately after engine is started to prevent overheating.

Run the engine about 3 minutes at a fast idle around 3500 RPM.

Pull plug from air intake silencer cover.

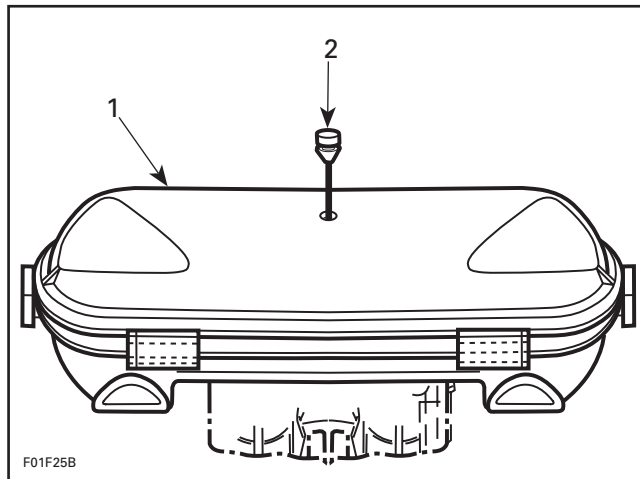

F01F25B

1. Air intake silencer cover
2. Pull plug

Spray BOMBARDIER LUBE lubricant through air intake silencer cover keeping engine at fast idle.

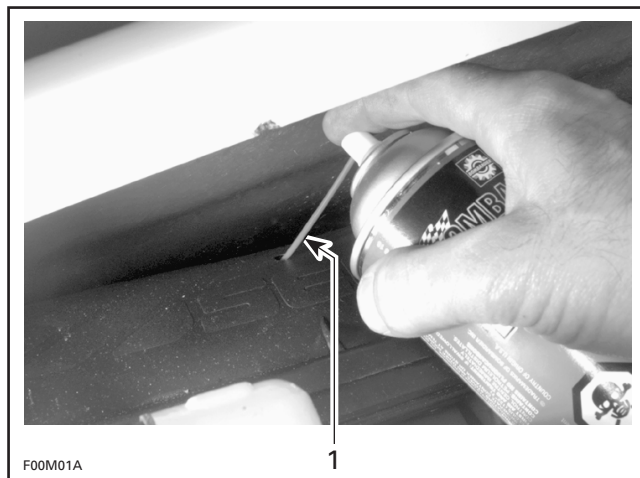

F00M01A

1

1. Spray Bombardier Lube

NOTE: Lubrication of engine should be done at least for one minute.

Section 01 MAINTENANCE

Sub-Section 03 (FLUSHING AND LUBRICATION)

After approximately half a minute, close fuel valve to run engine out of fuel while lubricating.

▼ CAUTION

When engine begins to run irregularly, immediately close the water tap to stop water flow before engine dies.

Disconnect the garden hose.

▼ CAUTION

If used, remove the quick hose connector from watercraft.

SP, SPX, GTS and XP Models

Unlock and remove coupler hose. Reinstall dust cap over fitting spigot.

Remove hose pincher from water outlet hose.

All Models

Wipe up any residual water from the engine.

Remove spark plug cables and connect them on the grounding device.

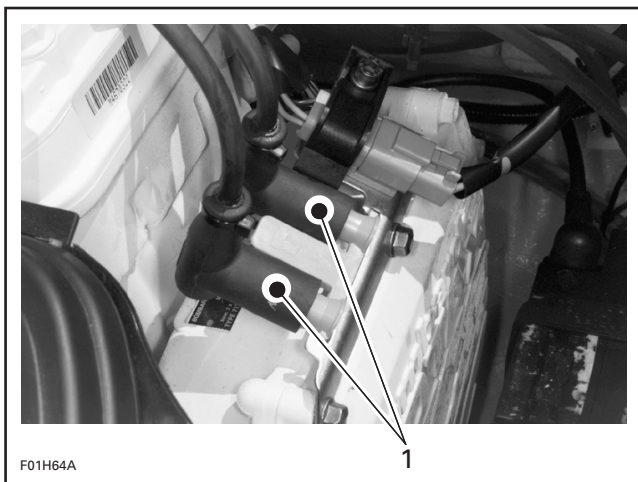

SP, GTS AND HX MODELS

1. Spark plug cables on grounding device

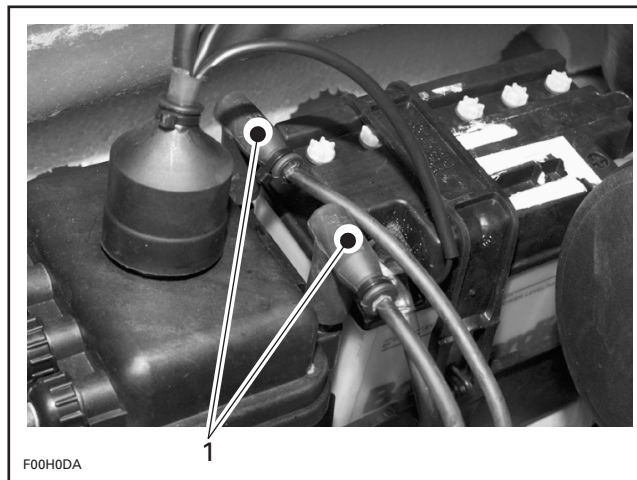

SPX, GS, GSI, GSX, GTI AND GTX MODELS

1. Spark plug cables on grounding device

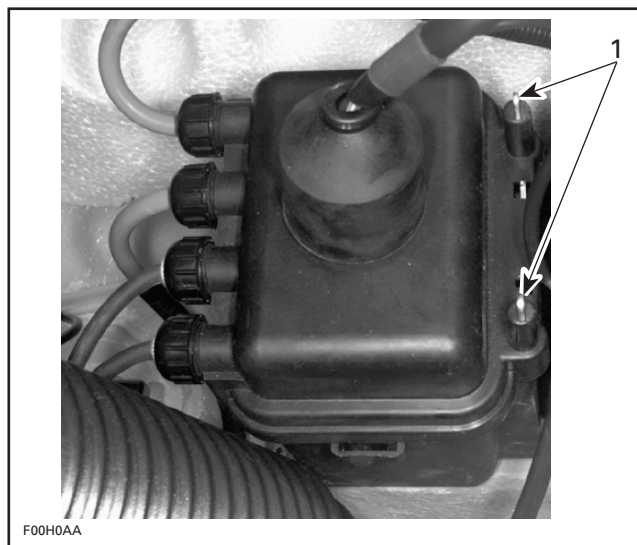

XP MODEL

1. Grounding device

Remove both spark plugs and spray BOMBARDIER LUBE lubricant into each cylinder.

Crank the engine a few turns to distribute the oil onto cylinder wall.

Apply anti-seize lubricant on spark plug threads then reinstall them.

Reinstall plug on air intake silencer cover.

Section 01 MAINTENANCE

Sub-Section 03 (FLUSHING AND LUBRICATION)

NOTE: Engine fogging should be done with BOMBARDIER LUBE lubricant whenever the watercraft is to be stored for a few days or a long period.



CAUTION

Never leave rags or tools in the engine compartment or in the bilge.

WATER-FLOODED ENGINE

GENERAL

If engine is water-flooded, it must be serviced within a few hours after the event. Otherwise engine will have to be overhauled.

▼ CAUTION

A water-flooded engine must be properly lubricated, operated then lubricated again, otherwise parts will be seriously damaged.

PROCEDURE

Check fuel and oil reservoirs for water contamination. If necessary, siphon and refill with fresh fluids.

Turn fuel valve to OFF position then drain fuel filter bowl. Refer to FUEL SYSTEM 05-02.

Drain bilge if water is present.

Remove spark plug cables and connect them on the grounding device.

◆ WARNING

Never crank engine with spark plugs removed unless spark plug cables are connected to the grounding device.

SP, GTS and HX Models

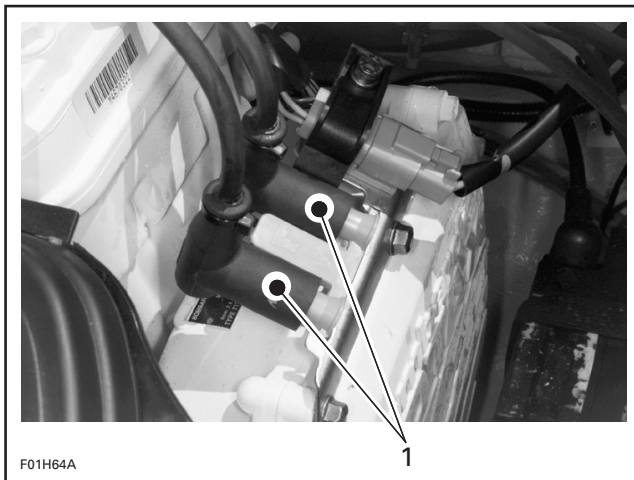

1. Spark plug cables on grounding device

SPX, GS, GSI, GSX, GTI and GTX

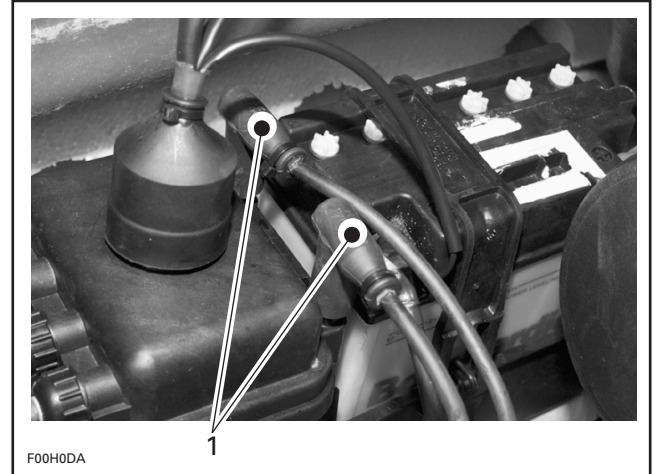

1. Spark plug cables on grounding device

XP Model

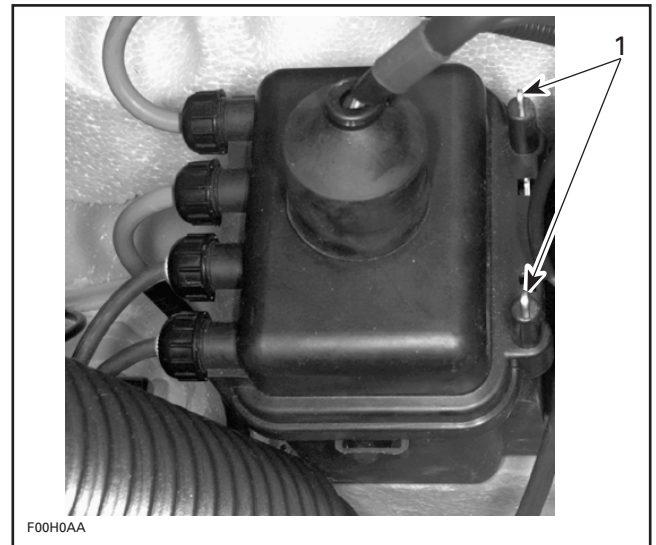

1. Grounding device

All Models

Remove spark plugs and dry them with a clean cloth. A contact cleaner spray can be used. It may be preferable to replace spark plugs. Do NOT install spark plugs on engine.

Crank engine to drain crankcase.

▼ CAUTION

Be careful when cranking engine, water will spray out from spark plug holes.

Section 01 MAINTENANCE

Sub-Section 04 (WATER-FLOODED ENGINE)

Spray BOMBARDIER LUBE lubricant (P/N 293 600 016) into spark plug holes.

Crank engine again.

Reinstall spark plugs and spark plug cables.

SPX, GSX, GTX and XP Models

On the 787 engine, remove the drain plug of the counterbalance shaft located on the PTO side of the lower crankcase.

Drain completely the crankcase oil of the counterbalance shaft. Reinstall drain plug.

Remove the filling plug located on the upper crankcase.

Add 30 mL (1 oz) of SAE 30 motor oil.

Reinstall filling plug.

All Models

Turn fuel valve to ON position.

Start engine; It may be necessary to use the choke. If engine does not start, repeat previous steps as necessary.

▼ CAUTION

To avoid starting motor overheating, the cranking period should not exceed 5-10 seconds and a rest period of 30 seconds should be observed between cranking cycles.

NOTE: If engine does not start after several attempts, check ignition system for spark occurrence. Refer to ELECTRICAL SYSTEM 07-02.

Check crankshaft if needed, it may be misaligned or deflected. Refer to ENGINE 03-06.

After engine has started, spray BOMBARDIER LUBE lubricant through air intake silencer while engine is running.

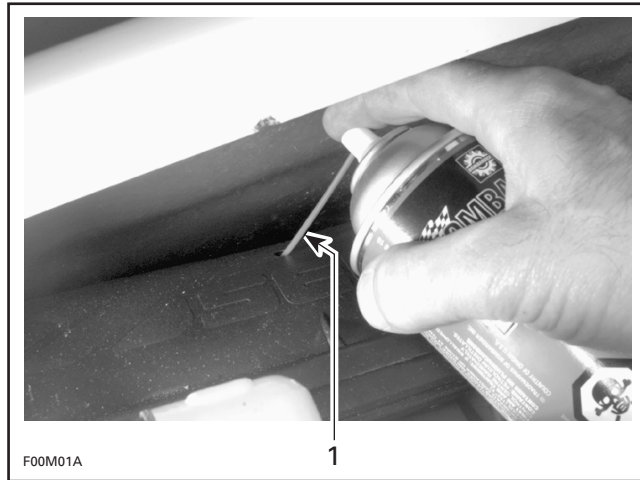

1. Spray Bombardier Lube

Run engine until it reaches its normal operating temperature.

▼ CAUTION

Engine must be cooled using the flush kit.

STORAGE

Engine Draining

Check engine drain hose. Make sure there is no sand or other particles in it and that it is not obstructed so that water can leave the engine. Clean hose and fitting as necessary.

▼ CAUTION

Water in engine drain hose must be free to flow out, otherwise water could be trapped in engine. Should water freeze in engine, severe damage will occur. Check engine drain hose for obstructions.

All Models Except XP and HX

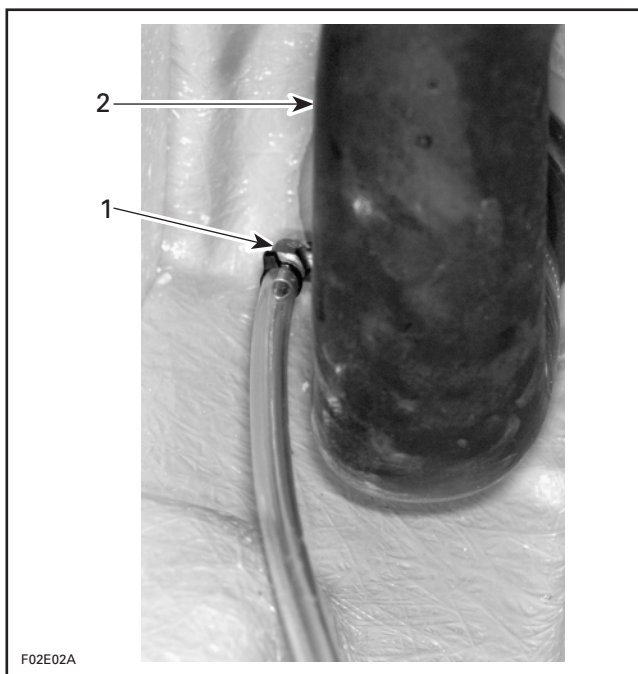

TYPICAL

- 1. Engine drain hose
- 2. Exhaust outlet

XP and HX Models



TYPICAL

- 1. Engine drain hose

Fuel System

Sea-Doo Fuel Stabilizer (P/N 413 408 600) should be added in fuel tank to prevent fuel deterioration and carburetor gumming. Follow manufacturer's instructions for proper use.

NOTE: Fuel stabilizer should be added prior engine lubrication to ensure carburetor protection against varnish deposit.

◆ WARNING

Fuel is flammable and explosive under certain conditions. Always work in a well ventilated area.

Always turn the fuel valve to OFF position when storing the watercraft.

Cooling System Flushing and Engine Internal Lubrication

Cooling system has to be flushed with fresh water to prevent salt, sand or dirt accumulation which will clog water passages.

Engine must be lubricated to prevent corrosion on internal parts.

For proper procedure, refer to MAINTENANCE 01-03.

Section 01 MAINTENANCE

Sub-Section 05 (STORAGE)

Propulsion System

Lubricant in impeller shaft reservoir should be drained. Reservoir should be cleaned and refilled with SEA-DOO synthetic 75W90 GL5 polyolester oil. Refer to PROPULSION SYSTEM 08-02.

▼ CAUTION

Use only SEA-DOO jet pump oil or equivalent synthetic gear oil, otherwise component life span could be reduced. Do not mix oil brands or types.

All Models Except XP and HX

Lubricate PTO flywheel at grease fitting with synthetic grease (P/N 293 550 010).

▼ CAUTION

Do not lubricate excessively. Immediately stop when a slight movement is noticed on rubber boot.

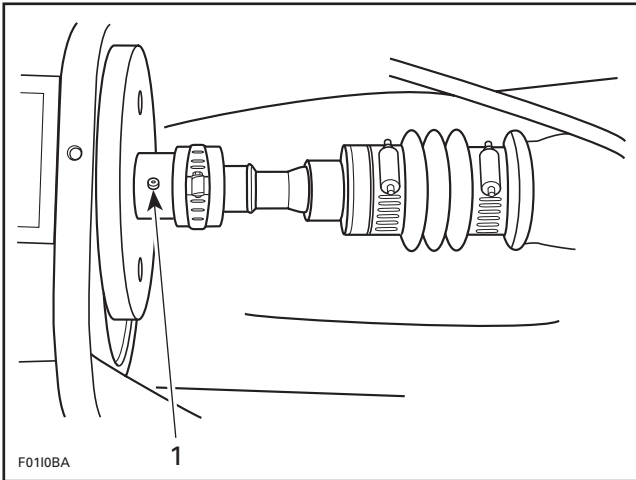

1. Grease PTO flywheel

▼ CAUTION

Never leave any clothing, tool or other objects near PTO flywheel and drive shaft.

XP and HX Models

Lubricate mid bearing of drive system at seal carrier grease fitting with synthetic grease.

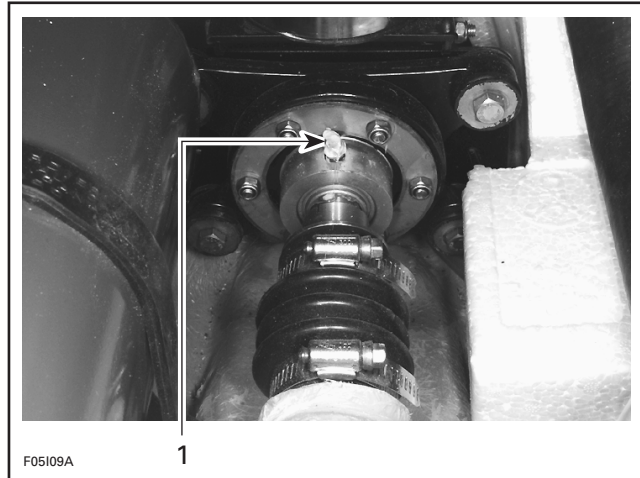

1. Grease fitting

Battery

For battery removal, cleaning and storage, refer to ELECTRICAL 07-03.

Watercraft Cleaning

Clean the bilge with hot water and mild detergent or with bilge cleaner. Rinse thoroughly. Lift front end of watercraft to completely drain bilge. If any repairs are needed to body or to the hull, touch up paint and Gelcote® repair kit are available. Replace damaged labels/decals.

Wash the body with soap and water solution (only use mild detergent). Rinse thoroughly with fresh water. Remove marine organisms from the hull. Apply a nonabrasive wax.

▼ CAUTION

Never clean apparent fiberglass and plastic parts with strong detergent, degreasing agent, paint thinner, acetone, etc.

If the watercraft is to be stored outside, cover it with an opaque tarpaulin to prevent sun rays and grime from affecting the plastic components, watercraft finish as well as preventing dust accumulation.

▼ CAUTION

The watercraft must never be left in water for storage. Never leave the watercraft stored in direct sunlight.

Anticorrosion Treatment

Wipe off any residual water in the engine compartment.

Spray BOMBARDIER LUBE lubricant over all metallic components in engine compartment.

Lubricate the throttle cable with BOMBARDIER LUBE lubricant.

NOTE: A cable luber can be used on throttle cable end to inject BOMBARDIER LUBE lubricant.

The seat should be partially left opened during storage (the engine cover for the XP and HX models). This will avoid engine compartment condensation and possible corrosion.

NOTE: If the watercraft is stored outside with seat (or the engine cover for the XP and HX models) partially opened and without a tarpaulin, unscrew the rear drain plug(s) in order to avoid water build up in the bilge during rainfall. Tilt the watercraft to the rear so that water can flow out.

Additional Recommended Protection

In cool regions (where freezing point temperature may be encountered), cooling system should be filled with water and antifreeze solution.

▼ CAUTION

Always use ethylene-glycol antifreeze containing corrosion inhibitors specifically recommended for aluminum engines.

NOTE: The engine will not have to run during this operation.

All Models Except XP and HX

Three hoses have to be disconnected to allow air to escape and antifreeze solution to completely fill cooling system water jackets.

Disconnect drain hose.

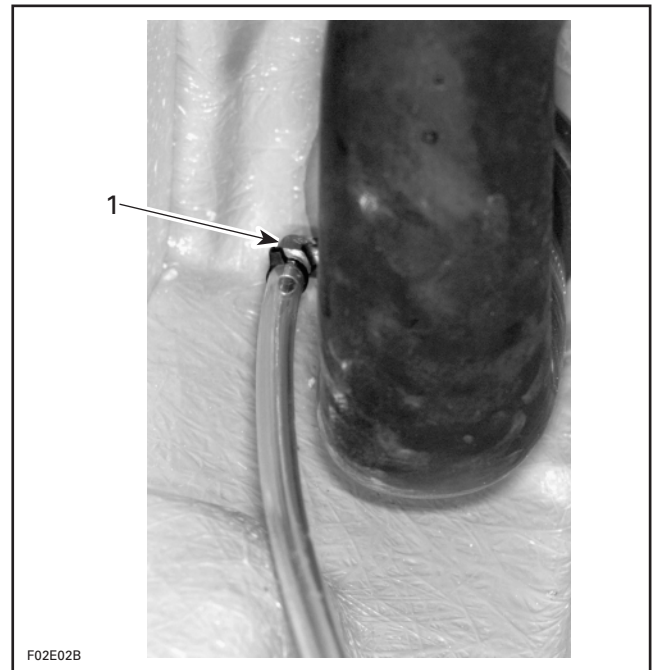

TYPICAL

1. Drain hose

Disconnect engine water supply hose and engine water return hose.

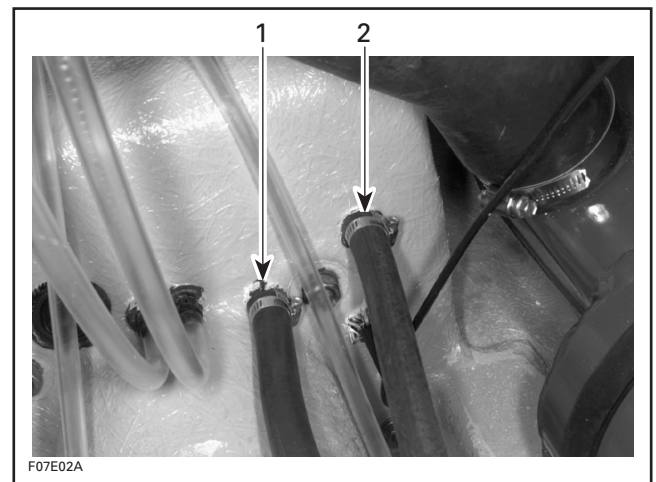

TYPICAL

1. Engine water supply hose
2. Engine water return hose

Raise all hoses above the highest point of tuned pipe and tie them together.

Insert a funnel into the engine water supply hose. Pour about 1 liter (1 quart) of antifreeze mixed with water in the engine.

Section 01 MAINTENANCE

Sub-Section 05 (STORAGE)

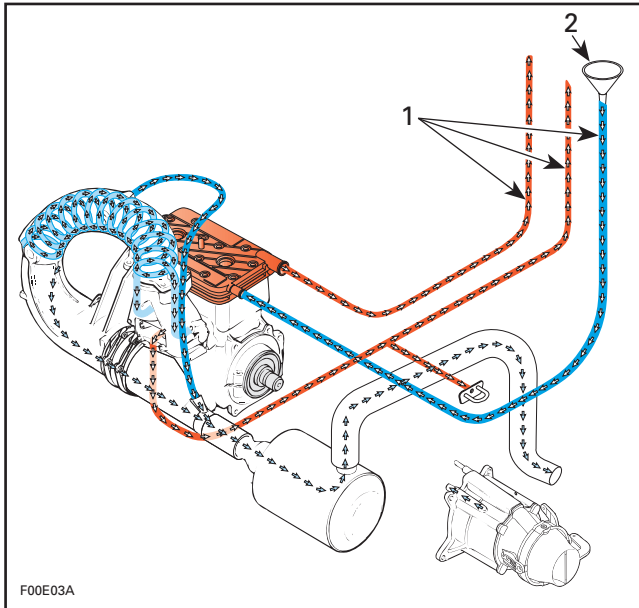

TYPICAL

1. Hold hoses higher than tuned pipe
2. Insert funnel into engine water supply hose

NOTE: If hoses are not attached higher than tuned pipe, coolant will drain out.

XP and HX Models

Install a hose pincher to engine drain hose.

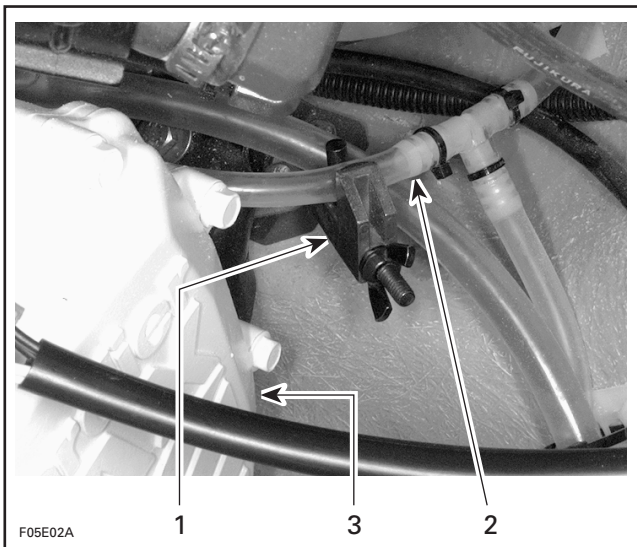

TYPICAL

1. Hose pincher
2. Drain hose
3. Magneto housing cover

Disconnect engine water supply hose and engine water return hose.

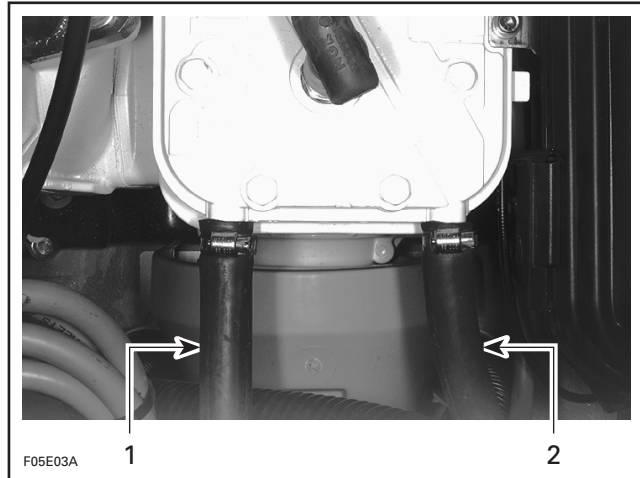

TYPICAL

1. Engine water supply hose
2. Engine water return hose

Install temporarily one hose to engine water inlet at cylinder head.

Insert a funnel into hose and pour about 1 liter (1 qt) of antifreeze mixed with water in engine.

Remove temporary hose and reconnect engine water supply hose and engine water return hose.

Remove hose pincher.

All Models

Most of the antifreeze will drain out when removing hose pinchers. Use a container to recover it. Dispose antifreeze as per your local laws and regulations.

NOTE: Although antifreeze will mainly drain out, the antifreeze has flowed to mix with water that was possibly trapped in cooling system cavities and thus preventing freezing problems.

NOTE: For pre-season preparation, drain antifreeze from cooling system prior to launching boat in water as explained above.

Section 02 TROUBLESHOOTING

Sub-Section 01 (TROUBLESHOOTING CHART)

ENGINE MISFIRES, RUNS IRREGULARLY

OTHER OBSERVATION	POSSIBLE CAUSE	REMEDY
Weak spark	<ul style="list-style-type: none">Fouled, defective, worn spark plugsFaulty rev limiter or ignition moduleSheared flywheel key	<ul style="list-style-type: none">Check/verify heat range/gap/replaceCheck, refer to section 07-02Check timing mark, refer to section 07-02
Lean fuel mixture Dry spark plug (except when water fouled)	<ul style="list-style-type: none">Low fuel levelStale or water fouled fuelFuel filter dirty or restrictedCarburetion dirty or out of adjustmentLeaking crankshaft seal(s), intake or rotary valve cover O-ringRestricted fuel valveLoose carburetor	<ul style="list-style-type: none">Check/refillCheck/siphon and refillCheck/clean/replaceCheck/clean/adjust, refer to section 05-04Pressure check engine, refer to 03-02 Check/replaceTighten carburetor(s)
Rich fuel mixture Fouled spark plug	<ul style="list-style-type: none">Partially closed chokeFlame arrester dirty or restrictedCarburetor adjustment or settingLoose main jet (if applicable)Rotary valve shaft seal leakingOil pump adjustmentWorn needle(s) and seal(s)Excessive rotary valve clearance	<ul style="list-style-type: none">Check/adjust choke cableCheck/clean/replaceCheck/clean/adjust, refer to section 05-04Check, refer to section 05-04Check/replace, refer to section 03-07Check/adjust, refer to section 06-03Check, refer to section 05-04Check, refer to section 03-07
Difficult to start	<ul style="list-style-type: none">Incorrect rotary valve timingExcessive rotary valve clearance	<ul style="list-style-type: none">Check/adjust, refer to section 03-07Check, refer to section 03-07

ENGINE OVERHEATS

OTHER OBSERVATION	POSSIBLE CAUSE	REMEDY
Monitoring beeper sounds continuously	<ul style="list-style-type: none">Restricted jet pump water intakeCooling system restrictionGrounded temperature sensor or sensor wire	<ul style="list-style-type: none">Check/cleanCheck/flush, refer to section 01-03Check/repair/replace

ENGINE CONTINUALLY BACKFIRES

OTHER OBSERVATION	POSSIBLE CAUSE	REMEDY
Weak spark	<ul style="list-style-type: none">Fouled, defective spark plugsMalfunction of rev limiter	<ul style="list-style-type: none">Clean/replaceClean/replace, refer to section 07-02
Ignition timing	<ul style="list-style-type: none">Incorrect settingSheared flywheel key	<ul style="list-style-type: none">Check/reset, refer to section 07-02Check/replace, refer to section 07-02 and 03-04
Rotary valve	<ul style="list-style-type: none">Incorrect timing	<ul style="list-style-type: none">Check/reset, refer to section 03-07
Carburetor	<ul style="list-style-type: none">Carburetion to lean	<ul style="list-style-type: none">Check/adjust, refer to section 05-04
Engine	<ul style="list-style-type: none">Intake leak/crankshaft seal failure	<ul style="list-style-type: none">Pressure check engine, refer to 03-02

Section 02 TROUBLESHOOTING
Sub-Section 01 (TROUBLESHOOTING CHART)

ENGINE DETONATION OR PINGING

OTHER OBSERVATION	POSSIBLE CAUSE	REMEDY
Ignition	<ul style="list-style-type: none"> Timing too far advanced Spark plug heat range too high Defective ignition module 	<ul style="list-style-type: none"> Check/reset Check/change to correct range Check/replace, refer to section 07-02
Engine temperature	<ul style="list-style-type: none"> Engine overheats Fuel of poor quality 	<ul style="list-style-type: none"> Check, refer to engine overheats Use good quality fuel

ENGINE LACKS ACCELERATION OR POWER

OTHER OBSERVATION	POSSIBLE CAUSE	REMEDY
<p>Engine revs lower than its maximum operational RPM (787 engine)</p> <p>Peak performance is delayed until higher RPM range is reached (787 engine)</p>	<ul style="list-style-type: none"> Weak spark Carburetion, jetting too rich/lean Throttle does not open fully Low compression Exhaust system restriction Water in fuel or oil Debris in carburetor needle valve Impeller leading edge damaged Twisted crankshaft RAVE valve does not open RAVE valve is stuck opened 	<ul style="list-style-type: none"> Check/replace, refer to section 07-02 Check/adjust, refer to section 05-04 Check/readjust, refer to section 05-04 Check/repair, refer to section 03-05 Check/clean Check/siphon/replace Check/clean, refer to section 05-04 Check/replace, refer to section 08-02 Check, refer to section 03-06 Check, refer to section 03-05 Check, refer to section 03-05

ENGINE RUNS TOO FAST

OTHER OBSERVATION	POSSIBLE CAUSE	REMEDY
Engine RPM too high	<ul style="list-style-type: none"> Faulty rev limiter Improper impeller pitch (too low) 	<ul style="list-style-type: none"> Check, refer to section 07-02 Check/replace, refer to section 08-02
Jet pump cavitation	<ul style="list-style-type: none"> Damaged leading or trailing edge of impeller Sealing of ride shoe or jet pump support/jet pump 	<ul style="list-style-type: none"> Check/replace <p>NOTE: Leading edge damage contributes to poor performance from start. Trailing edge damage contributes to poor top performance and stator vanes erosion.</p> <ul style="list-style-type: none"> Check/reseal, refer to section 08-02 or 11-02

ABNORMAL NOISE FROM PROPULSION SYSTEM

OTHER OBSERVATION	POSSIBLE CAUSE	REMEDY
	<ul style="list-style-type: none"> Weeds/debris caught in intake grate or impeller Low oil level in pump housing Worn anti-knocking system Damaged or bent drive shaft Broken motor mounts 	<ul style="list-style-type: none"> Check/clean Check/troubleshoot source of leak/refill supply, refer to section 08-02 Check/replace pusher in cover, refer to section 08-02 Check/replace, refer to section 08-03 Check/replace, refer to section 03-03

TABLE OF CONTENTS

LEAK TEST	03-02-1
GENERAL	03-02-1
PREPARATION	03-02-1
TESTING PROCEDURE	03-02-1
ENGINE LEAKAGE DIAGNOSTIC FLOW CHART	03-02-6

REMOVAL AND INSTALLATION	03-03-1
GENERAL	03-03-1
ENGINE REMOVAL	03-03-1
CLEANING	03-03-4
INSTALLATION	03-03-4

MAGNETO SYSTEM	03-04-1
GENERAL	03-04-3
REMOVAL	03-04-3
CLEANING	03-04-6
DISASSEMBLY	03-04-6
ASSEMBLY	03-04-8
INSTALLATION	03-04-9

TOP END	03-05-1
GENERAL	03-05-3
DISASSEMBLY	03-05-5
CLEANING	03-05-7
INSPECTION	03-05-8
ASSEMBLY	03-05-11
ADJUSTMENT	03-05-18

BOTTOM END	03-06-1
CRANKSHAFT MISALIGNMENT AND DEFLECTION	03-06-3
DISASSEMBLY	03-06-4
CLEANING	03-06-7
INSPECTION	03-06-7
ASSEMBLY	03-06-9

ROTARY VALVE	03-07-1
GENERAL	03-07-2
INSPECTION ON WATERCRAFT	03-07-2
DISASSEMBLY	03-07-4
CLEANING	03-07-5
INSPECTION	03-07-6
ASSEMBLY	03-07-6

Section 03 ENGINE

Sub-Section 01 (TABLE OF CONTENTS)

EXHAUST SYSTEM	03-08-1
TUNED PIPE REMOVAL	03-08-4
EXHAUST MANIFOLD REMOVAL.....	03-08-6
MUFFLER REMOVAL.....	03-08-6
TUNED PIPE REPAIR	03-08-6
INSTALLATION	03-08-7

LEAK TEST

GENERAL

A Sea-Doo Engine Leak Test Kit (P/N 295 500 352) is available to help diagnose engine problems such as engine seizure, poor performance, oil leakage, etc.

Before disassembling any components of the engine, it is important to perform a leakage test to determine which part is defective.

It is also very important after servicing the engine, even for a complete engine rebuilt, to perform another leakage test; at this stage, it may avoid further engine problems and minimizing the risk of having to remove and reinstall the engine again.

Static bench testing is the most effective way to conduct a leakage test. Inboard testing does not allow complete access to, and observation of all engine surfaces and should be avoided whenever possible.

On 717 engines, cylinders can not be verified individually due to leakage from one cylinder to another through a common intake manifold.

When installing hoses of the Engine Leak Test Kit, use the collars provided in the kit to ensure a proper sealing.

When pressurizing the engine, first confirm that the components of the Engine Leak Test Kit are not leaking by spraying a solution of soapy water on all hoses, connections, fittings, plates, etc. If there is a leak, bubbles will indicate leak location.

Three areas of the engine will be tested in sequence as per the diagnostic flow chart (see the end of this sub-section).

1. Engine Cooling System
2. Bottom End and Top End
3. Rotary Valve Shaft

NOTE: If a leak is found, it is important to continue testing as there is the possibility of having more than one leak. Continue pumping to compensate for the air lost to find another leak.

PREPARATION

Verify fuel system for leaks.

◆ WARNING

If any fuel leak is found, do not start the engine. Correct the leak and wipe off any fuel spillage. Do not use electric powered tools unless fuel system has passed pressure test.

Disconnect battery BLACK negative cable.

◆ WARNING

Always disconnect battery cables in the specified order, BLACK negative cable first.

Disconnect battery RED positive cable.

TESTING PROCEDURE

Engine Cooling System

Remove the tuned pipe.

Remove the exhaust manifold gasket and ensure the surface is cleaned.

Disconnect engine cooling hoses.

Install the appropriate exhaust manifold plate (**no. 1** for the 787 engine and **no. 2** for 717 engines) from the Engine Leak Test Kit. Tighten plate using fasteners provided in the kit.

Use hoses provided in the kit and install them on the engine.

Install pump using reducer and appropriate tube(s) as necessary.

Section 03 ENGINE

Sub-Section 02 (LEAK TEST)

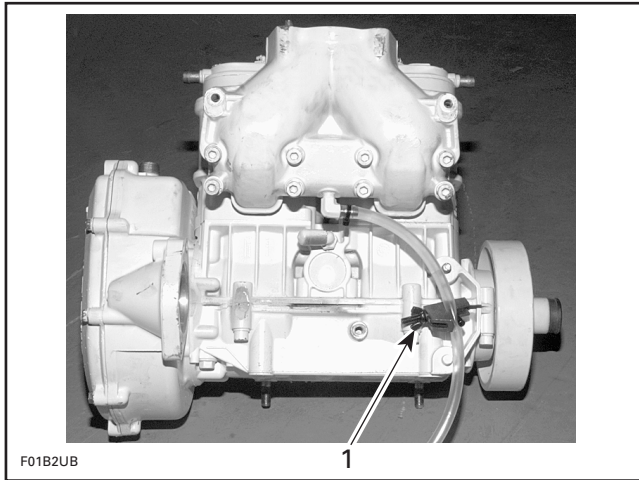

717 ENGINES — REAR VIEW

1. Engine drain hose blocked with a hose pincher

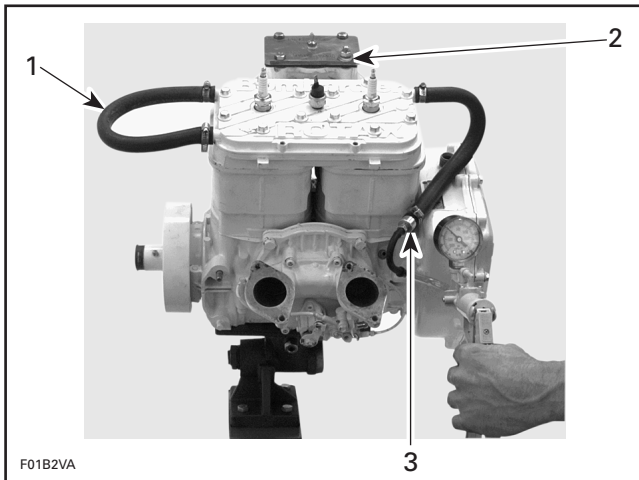

717 ENGINES — FRONT VIEW

1. Loop hose and use clamps
2. Use 2 washers with exhaust manifold stud
3. Hose with adapter and nipple

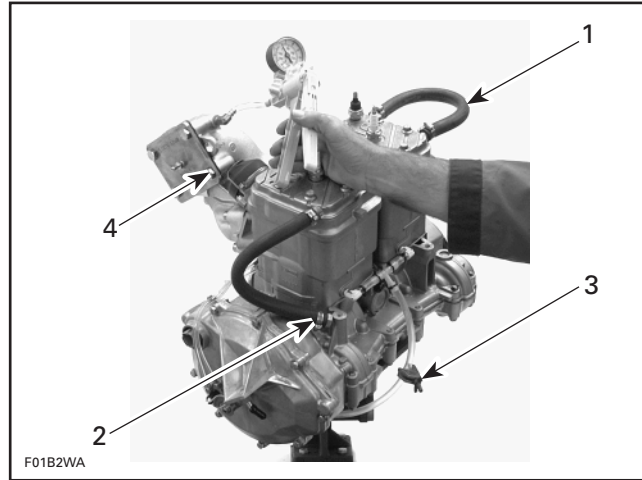

787 ENGINE

1. Loop hose and use clamps
2. Hose with clamps. Plug end with a screw
3. Block engine drain hose with a hose pincher
4. Use 2 washers with exhaust manifold stud

NOTE: Water is not required for testing.

Activate pump and pressurize engine cooling system to 34 kPa (5 PSI).

Wait 3 minutes and check if pressure drops; if so, verify all testing components.

- If kit components are not leaking and pressure drops, verify all external jointed surfaces, temperature sensor and the O-ring between the spark plug area and the engine cylinder head cover. If none of these components are leaking, there is an internal leak and it can be detected with Bottom End and Top End testing.

Bottom End and Top End

Remove the carburetor(s) and gasket(s). Make sure the surface of the intake manifold (717 engines) or rotary valve cover (787 engine) are clean.

NOTE: With the BN-38 carburetor, intake manifold must be removed first to withdraw carburetor; Then, reinstall intake manifold to proceed with testing.

Install the intake plate(s) **no. 3** with fasteners from the kit and tighten adequately.

On engines with the RAVE system, remove the RAVE valves and gaskets.

Install plates **no. 4** with fasteners from the kit and tighten adequately.

NOTE: On engines with the RAVE system, the boot and O-ring can be checked for leakage with the valve in place. Simply remove the cover to expose the boot.

Make sure the spark plugs are installed and tightened.

Block pulse hose using a hose pincher.

NOTE: Do not block the rotary valve shaft hoses.

Install pump to the exhaust plate fitting.

Activate pump and pressurize engine to 34 kPa (5 PSI).

▼ CAUTION
Do not exceed this pressure.

Wait 3 minutes and check if pressure drops; if so, verify all testing components.

If kit components are not leaking, verify engine jointed surfaces as per following areas:

- spark plugs
- cylinder head gasket
- cylinder base gasket
- crankcase halves
- rotary valve cover
- engine plugs
- exhaust manifold
- intake manifold (717 engines)
- oil injection pump (717 engines)

Check also small oil injection pump lines and fittings; check for air bubbles or oil column going toward pump, which indicate a defective check valve.

If the above mentioned components are not leaking, block both oil hoses of the rotary valve shaft using hose pinchers.

NOTE: If leakage stops at this point, proceed with **Rotary Valve Shaft** testing.

If there is still some leakage, remove the PTO flywheel to verify outer seal.

If no leak is found on the PTO side outer seal, remove magneto flywheel and verify crankshaft outer seals.

Proceed with the **Rotary Valve Shaft** testing if the crankshaft outer seals are not leaking.

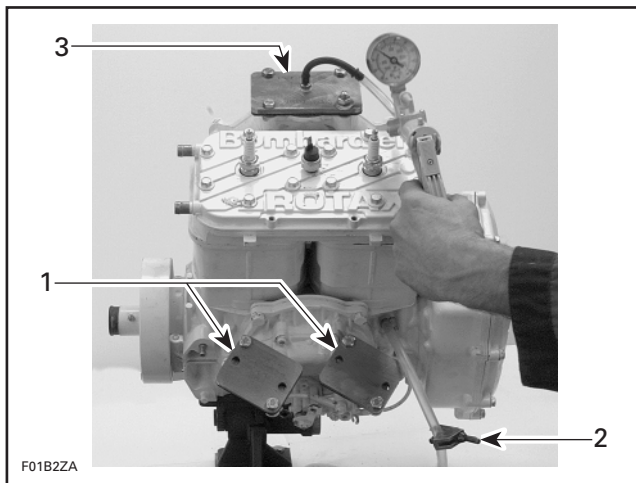

717 ENGINES

1. Intake plates
2. Pulse hose blocked with a hose pincher
3. Exhaust plate

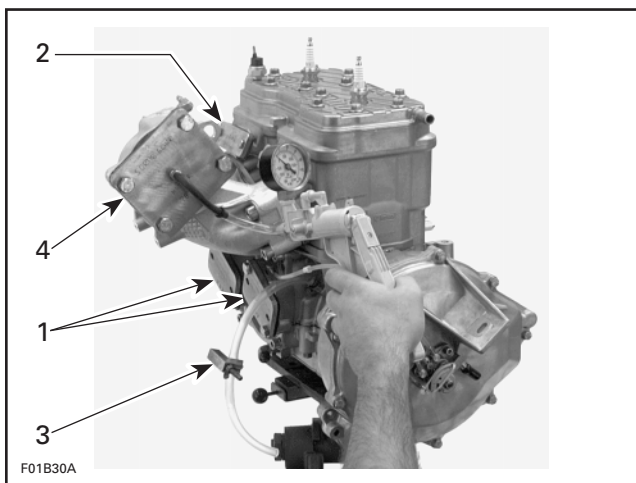

787 ENGINE

1. Intake plates
2. RAVE valve plates
3. Pulse hose blocked with a hose pincher
4. Exhaust plate

Section 03 ENGINE

Sub-Section 02 (LEAK TEST)

Rotary Valve Shaft

NOTE: It is preferable to drain the injection oil from the rotary valve shaft, but it is not mandatory.

Block oil return hose of the rotary valve shaft with a hose pincher.

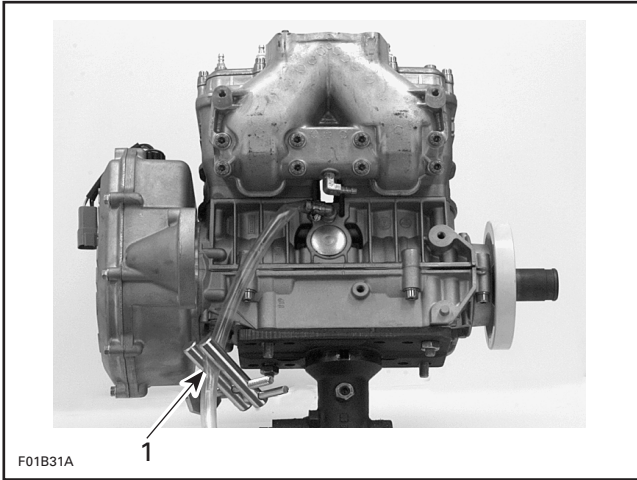

717 ENGINES

1. Oil return hose blocked with hose pincher

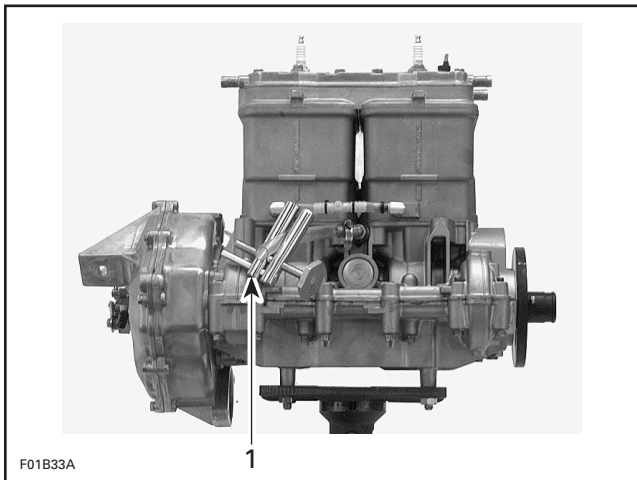

787 ENGINE

1. Oil return hose blocked with hose pincher

Install pump with reducer and nipple to the oil supply hose of the rotary valve shaft.



717 ENGINES

1. Pump with reducer and nipple

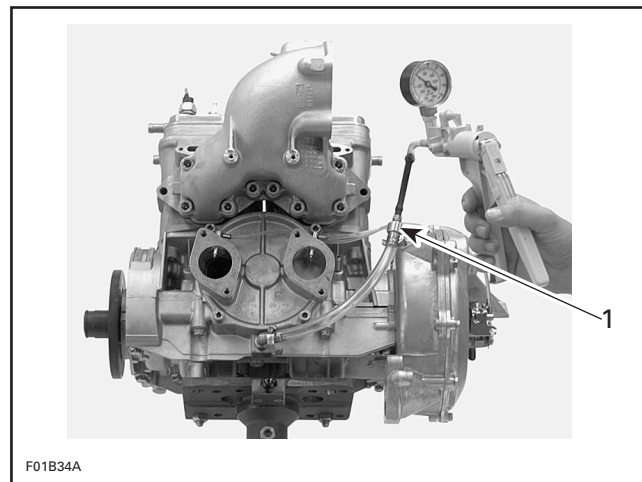

787 ENGINE

1. Pump with reducer and nipple

Activate pump and pressurize to 5 PSI (34 kPa).

Check plug of the rotary valve shaft in crankcase.

Remove PTO side spark plug. If pressure drops, it indicates a defective PTO side crankshaft inner seal.

Remove MAG side spark plug. If pressure drops, it indicates a defective MAG side crankshaft inner seal.

If the above mentioned components are not leaking and there is a pressure drops, remove the rotary valve cover. Check the seal of the rotary valve shaft.

If the rotary valve shaft is not leaking, it could indicates a defective engine casting. Disassemble engine and carefully check for defects in castings. Pay attention to tapped holes which may go through sealed areas of engine and thus lead to leakage.

Section 03 ENGINE

Sub-Section 02 (LEAK TEST)

ENGINE LEAKAGE DIAGNOSTIC FLOW CHART

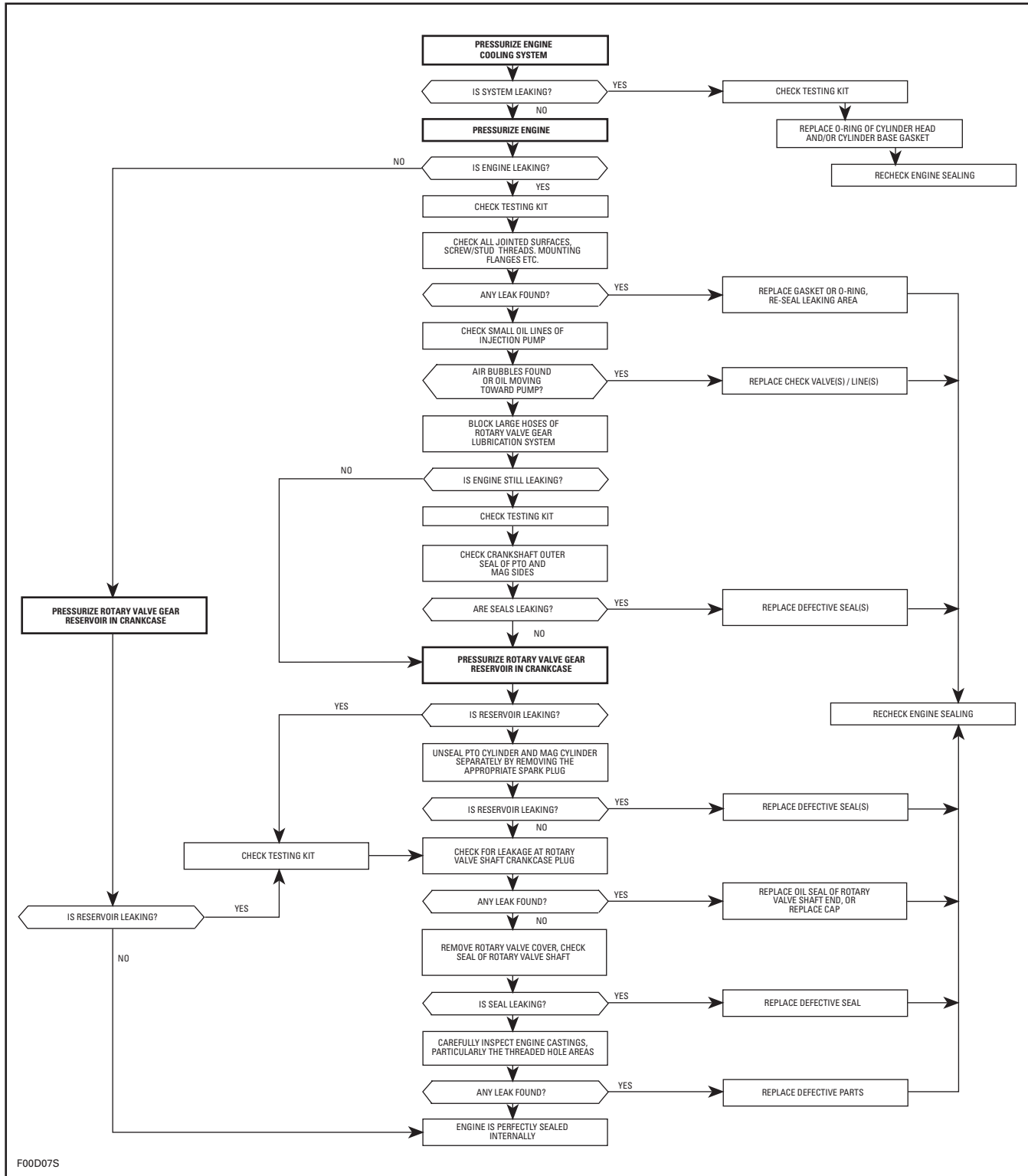

F00D07S

REMOVAL AND INSTALLATION

GENERAL

It is not necessary to remove engine from watercraft for TOP END nor PTO FLYWHEEL AND MAGNETO servicing. However engine removal is necessary to repair BOTTOM END.

ENGINE REMOVAL

In order to remove engine from watercraft proceed as follows.

▼ CAUTION

Whenever removing engine from watercraft, engine/jet pump alignment must be performed.

Jet Pump Removal

To withdraw jet pump, refer to PROPULSION SYSTEM 08-02.

Drive System

To withdraw driveshaft(s), refer to PROPULSION SYSTEM 08-03.

All Models

Electrical Connections

First, remove BLACK negative cable from battery, then RED positive cable.

◆ WARNING

Always disconnect starter or battery cables exactly in the specified order, BLACK negative cable first. It is recommended to disconnect electrical connections prior to disconnecting fuel lines.

SP and GTS Models

Remove battery holding straps and disconnect vent tube from battery.

Remove battery.

All Models

Disconnect temperature switch wire and spark plug cables.

Disconnect magneto wiring harness.

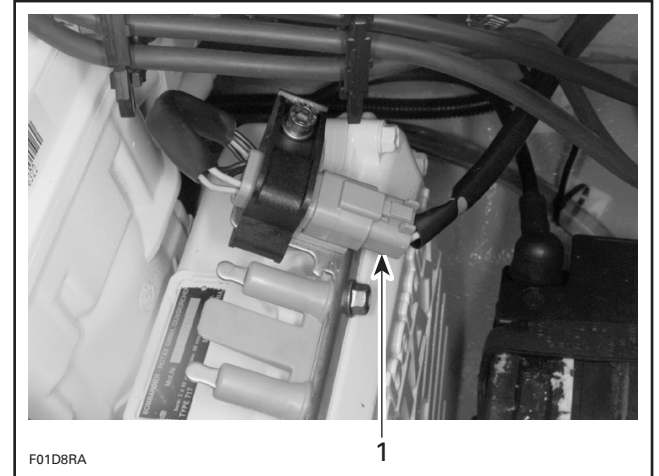

F01D8RA

TYPICAL — 717 ENGINES

1. Unplug connector

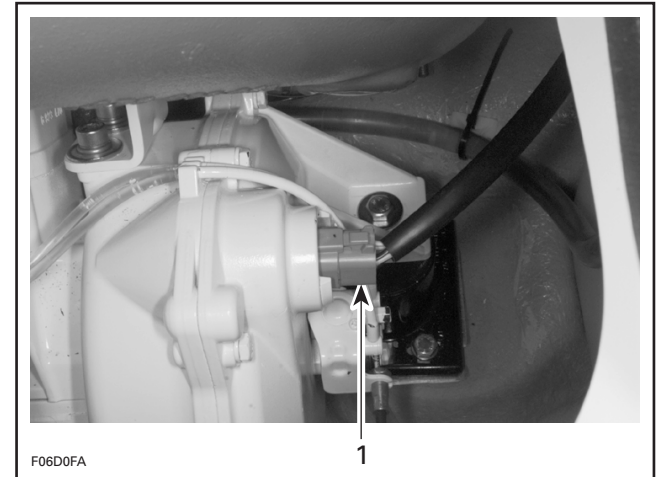

F06D0FA

787 ENGINE

1. Unplug connector

Tuned Pipe

To remove tuned pipe, refer to ENGINE 03-08.

Air Intake Silencer

To remove air intake silencer, refer to FUEL SYSTEM 05-03.

Carburetor(s)

All Models Except the XP and HX

To remove carburetor(s), refer to FUEL SYSTEM 05-04.

Section 03 ENGINE

Sub-Section 03 (REMOVAL AND INSTALLATION)

XP and HX Models Only

Disconnect choke and throttle cables from carburetor linkage.

Disconnect fuel supply and fuel return hoses.

Engine Support(s)

NOTE: Be careful when removing engine support(s) or rubber mount adapters, shims could have been installed underneath. Shims control engine/jet pump alignment. Always note position of shims for reinstallation, to avoid altering engine alignment.

Remove engine support mount screws.

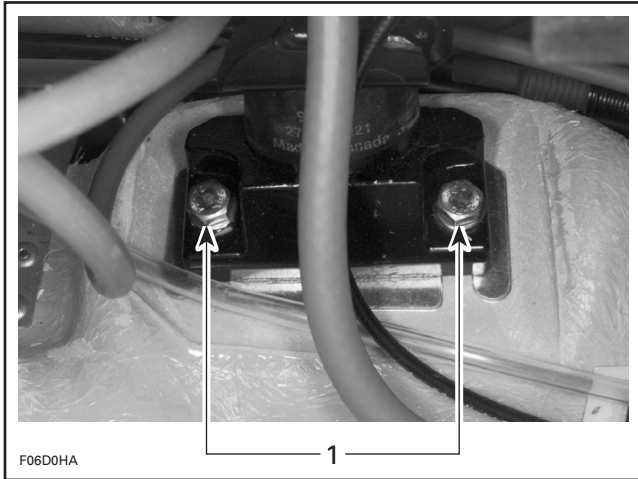

TYPICAL

1. Remove screws

Lifting Engine

717 Engines

Engine can be easily lifted using the following suggested tools:

- Cut porcelain from 2 old spark plugs.
- Weld a lock washer approximately 20 mm diameter on each spark plug as shown.

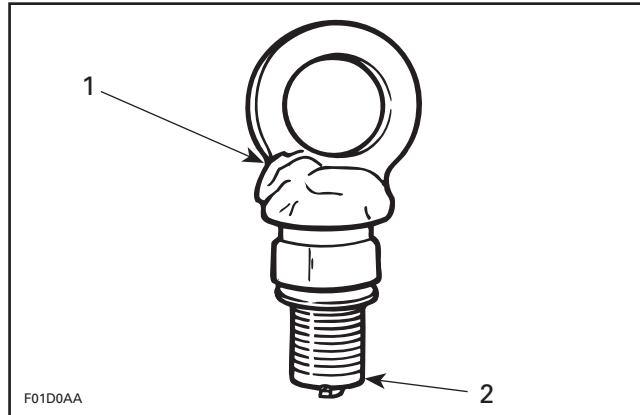

1. Weld a lock washer
2. Old spark plug

Remove spark plugs and replace by special tools. Hook a sling into holes of special tools.

Using a chain block, a hoist or other suitable equipment, slightly lift engine to ease the remaining component removal.

CAUTION

Take care not to damage cable or oil injection hoses.

787 Engine

Engine can be easily lifted by inserting a hook into exhaust manifold eyelet.

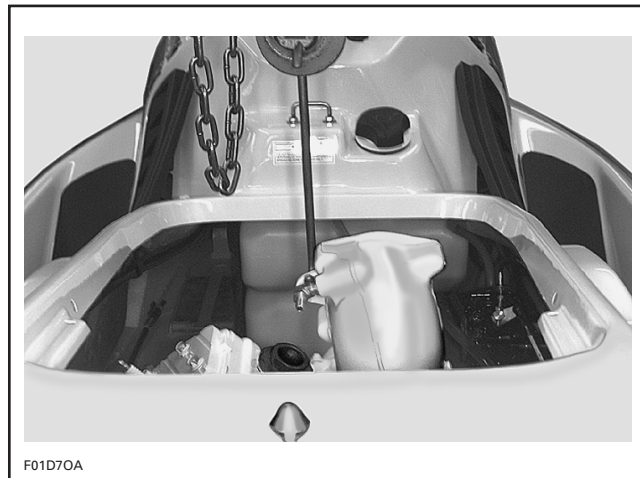

TYPICAL

Using a chain block, a hoist or other suitable equipment, slightly lift engine to ease the remaining component removal.

▼ CAUTION

Take care not to damage cable or oil injection hoses.

Remove rear engine support.

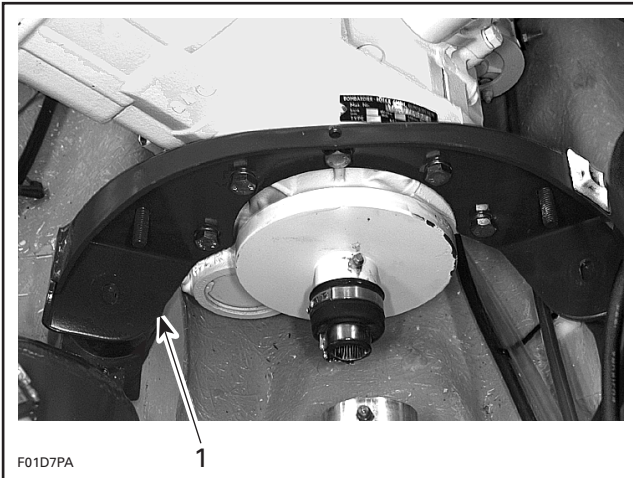

1. Rear support

All Engines

Install a hose pincher to oil supply hoses of oil injection pump and rotary valve shaft; then, disconnect hoses.

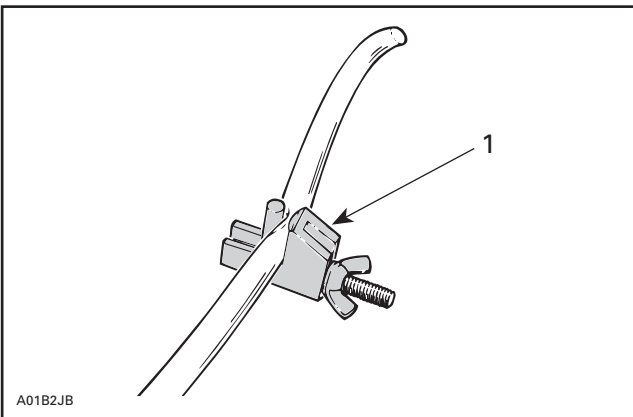

TYPICAL

1. Hose pincher (P/N 295 000 076)

Install a hose pincher to oil return hose of rotary valve shaft; then, disconnect hose.

Disconnect RED positive cable from starter post.

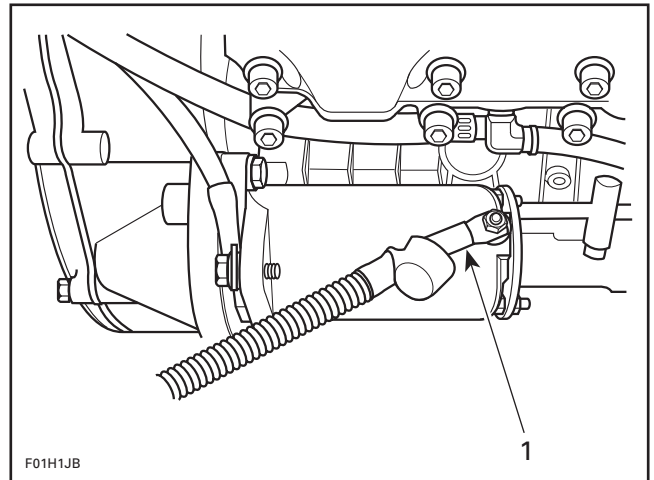

TYPICAL

1. Disconnect RED positive cable

Carry on engine lifting then tilt engine so that it can be removed from the body opening.

▼ CAUTION

Be careful not to scratch body or to hit any component.

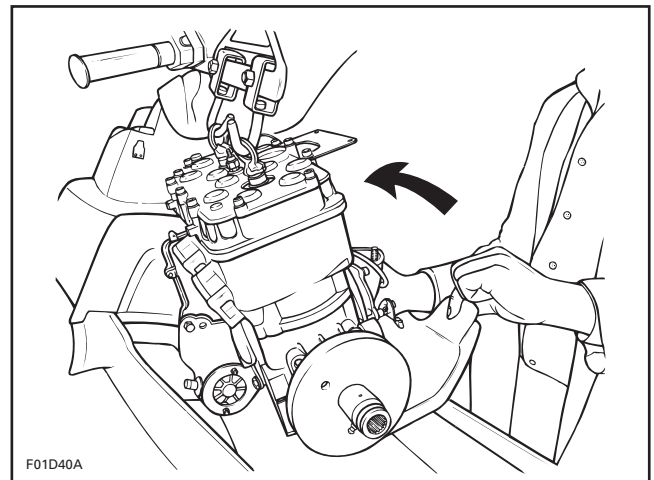

TYPICAL — ALL ENGINES EXCEPT THE 787

Section 03 ENGINE

Sub-Section 03 (REMOVAL AND INSTALLATION)

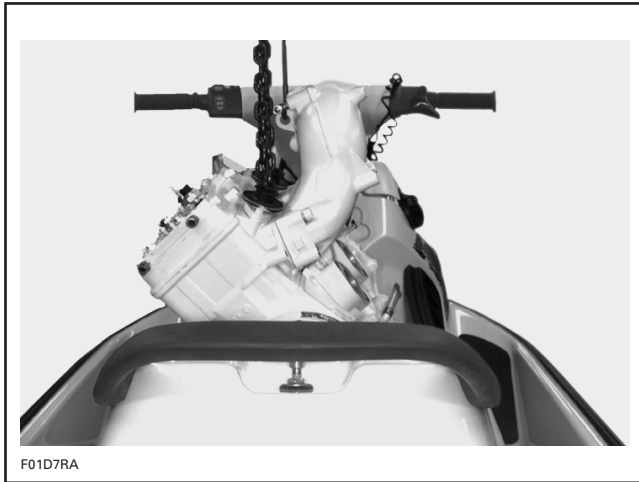

TYPICAL — 787 ENGINE

CLEANING

Wipe off any spillage in bilge. Clean with a bilge cleaner.

Clean external parts of engine.

INSTALLATION

Installation of engine in watercraft is essentially the reverse of removal procedures. However pay particular attention to the following.

Rubber Mount, Shim and Screw

Check tightness and condition of rubber mounts. If they have been removed, apply Loctite 242 (blue) on screw threads. Torque screws to 25 N•m (18 lbf•ft).

CAUTION

Strict adherence to this torque is important to avoid damaging threads of aluminum insert in bilge.

Engine Support(s)

717 Engines

One-Piece Engine Support

Properly install support on crankcase so that rounded portion of support matches with MAG side of crankcase. Apply Loctite 242 (blue) on threads then torque nuts in a criss-cross sequence to 35 N•m (26 lbf•ft).

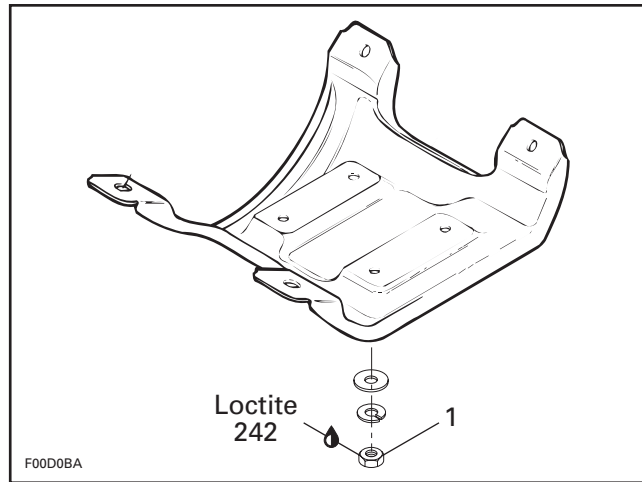

TYPICAL

1. Torque to 35 N•m (26 lbf•ft)

Four-Piece Engine Support

Torque front and rear engine supports as shown in the following illustration.

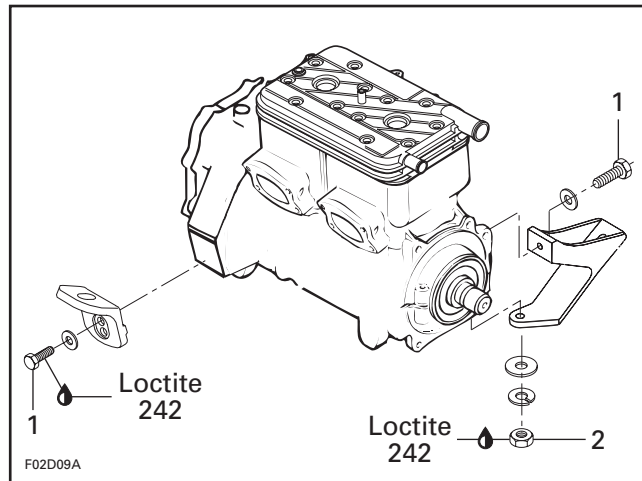

1. Torque screws to 22 N•m (16 lbf•ft)

2. Torque nuts to 39 N•m (29 lbf•ft)

Oil Injection Hoses

Make sure to reinstall hoses before completely lowering engine in bilge.

Positive Starter Cable

Torque nut of positive starter cable to 6 N•m (53 lbf•in). Apply dielectric grease on nut.

Engine/Jet Pump Alignment

Alignment is necessary to eliminate possible vibration and/or damage to components. Check alignment of engine using the following alignment tools.

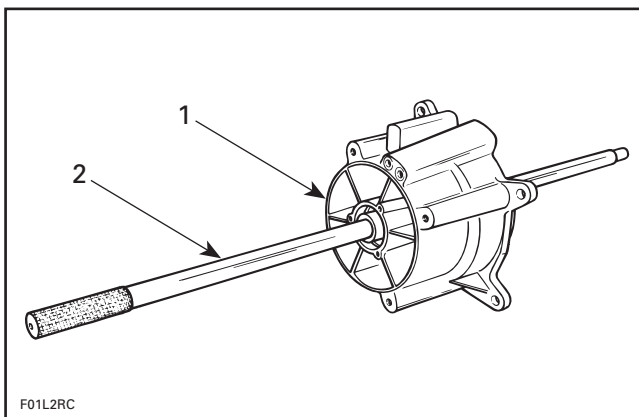

1. Housing (P/N 295 000 090)
 2. Alignment shaft (P/N 295 000 093) or (P/N 295 000 141) for the HX and XP models

HX and XP Models

On these models, the PTO flywheel adapter (P/N 295 000 157) must be used in conjunction with the alignment shaft.

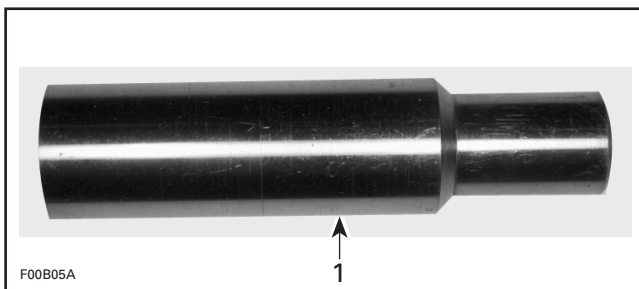

1. Adapter P/N 295 000 157

NOTE: Ensure the mid bearing is removed to check engine alignment.

All Models

To verify alignment proceed as follows:

- Install housing on hull with 4 nuts.
- Carefully slide shaft through housing.

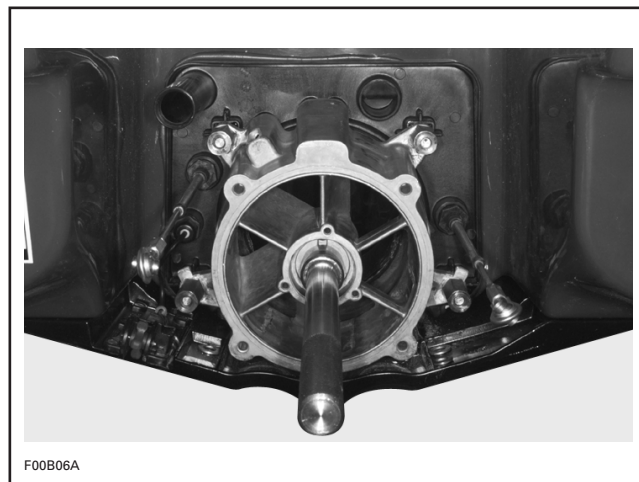

TYPICAL

- Insert shaft end into PTO flywheel.

NOTE: Ensure the protective hose and carbon ring is removed to check engine alignment. If the alignment is correct, the shaft will slide easily without any deflection in PTO flywheel.

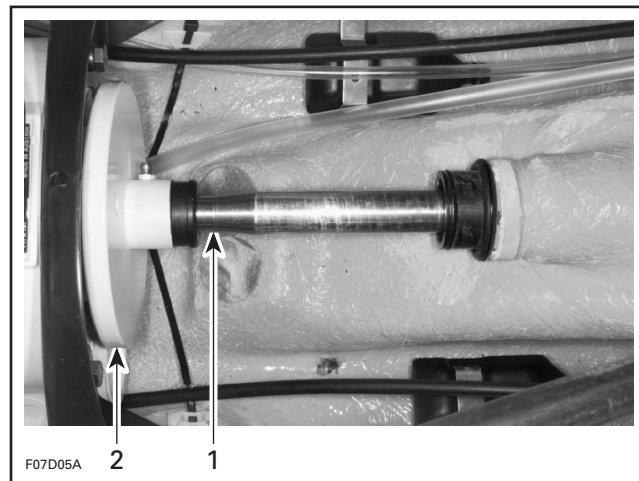

TYPICAL

- 1. Alignment shaft
- 2. PTO flywheel

If the alignment is incorrect loosen engine support screws to enable to align PTO flywheel with shaft end.

NOTE: Use shim(s) (P/N 270 000 024) or (P/N 270 000 025) as necessary between engine support and rubber mounts to correct alignment.

Section 03 ENGINE

Sub-Section 03 (REMOVAL AND INSTALLATION)

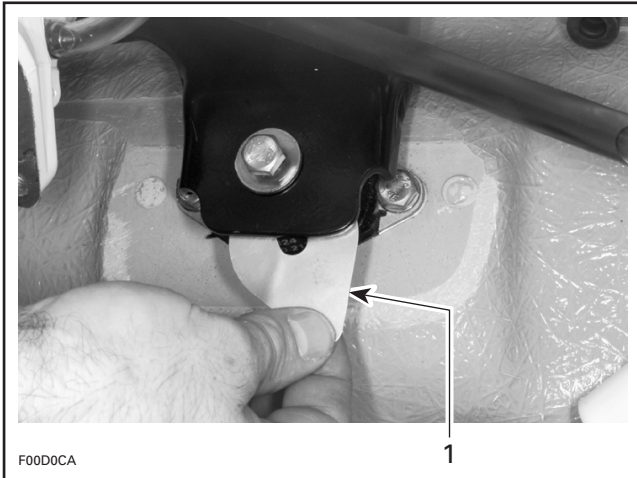

TYPICAL

1. Shim

▼ CAUTION

Whenever shims are used to correct alignment, never install more than 6 mm (0.240 in) shim thickness. If alignment cannot be obtained verify for engine support bending.

Engine Support Screws

Apply Loctite 242 (blue) on screw threads.

Torque engine support screws to 25 N•m (18 lbf•ft) when procedure is completed.

NOTE: Whenever alignment tool is not utilized, apply BOMBARDIER LUBE lubricant on its shaft and inside the housing to eliminate possible corrosion.

Final Inspection

Check throttle cable condition and lubricate cable with BOMBARDIER LUBE lubricant. After its installation, properly adjust and bleed oil injection pump as specified in LUBRICATION SYSTEM 06-03.

Check hose condition and pressure test fuel system, refer to FUEL SYSTEM 05-02.

Verify all electrical connections.

Run engine and ensure there is no leakage.

▼ CAUTION

If watercraft is out of water, engine must be cooled using the flush kit.

MAGNETO SYSTEM

717 Engines

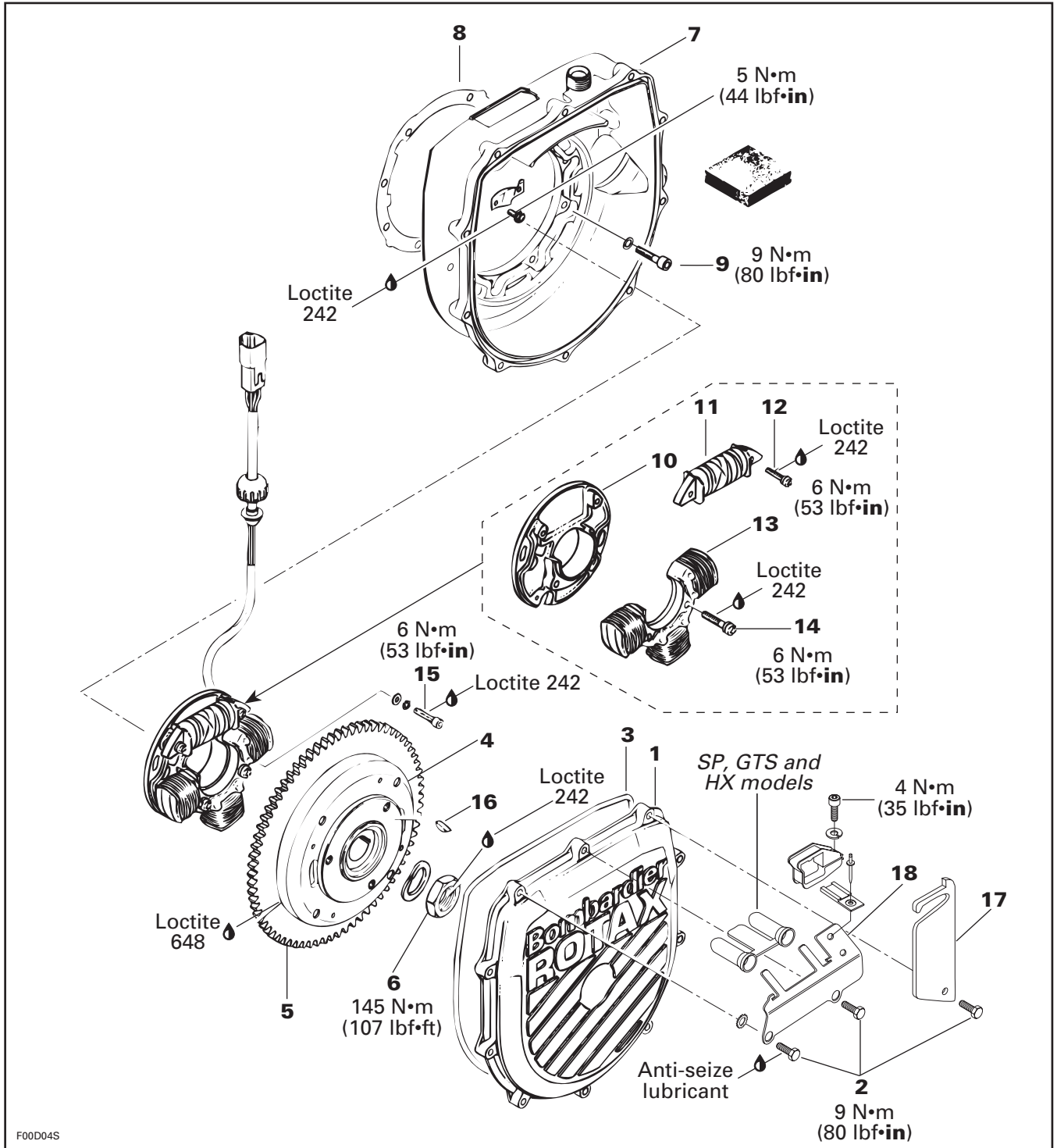

F00D04S

Section 03 ENGINE

Sub-Section 04 (MAGNETO SYSTEM)

787 Engine

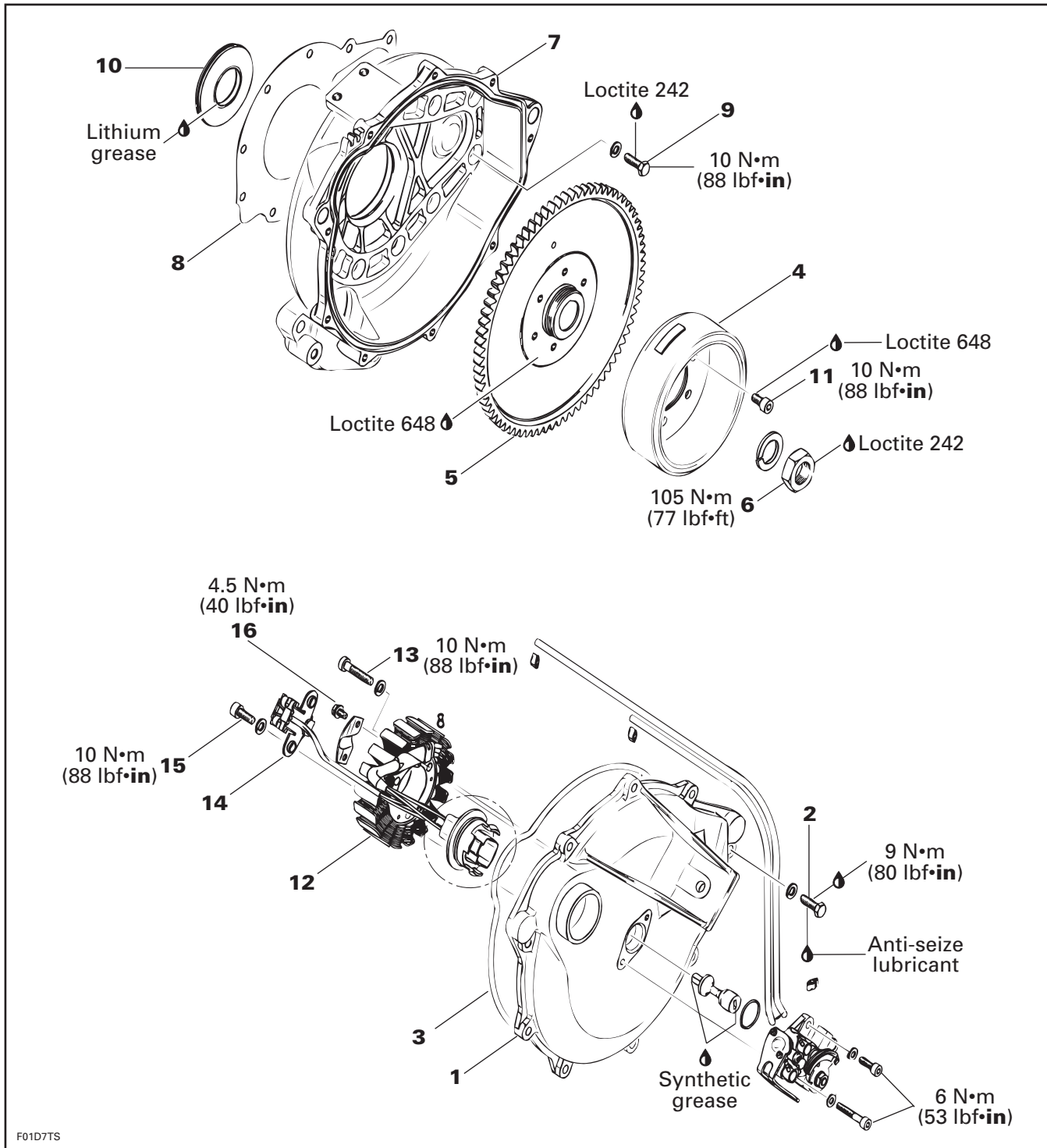

GENERAL

The following procedures can be performed without removing engine from watercraft. However, battery removal will be required on SP and GTS models.

REMOVAL

717 Engines

1, Magneto Housing Cover

Remove screws no. 2, wire supports no. 17 and no. 18, then withdraw cover.

4,5, Magneto Flywheel and Ring Gear

Magneto flywheel is locked with puller plate (P/N 290 876 080), sleeves (P/N 290 847 220) and extension handle (P/N 295 000 111).

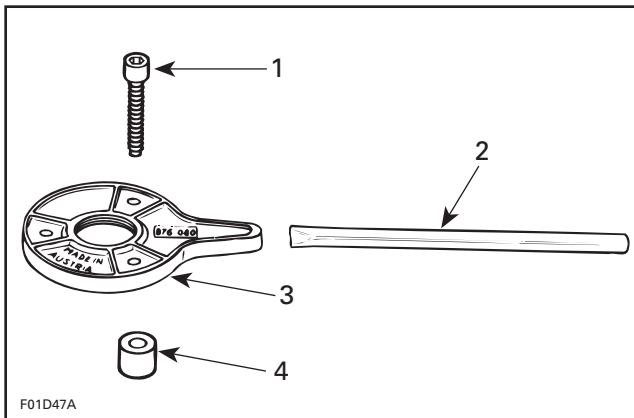

1. Screw
2. Extension handle
3. Puller plate
4. Sleeve

Using 3 M8 x 35 screws (P/N 290 841 591), install screws through puller plate and slide sleeves on screws then secure puller plate on magneto flywheel so that sleeves are against flywheel.

Install extension handle on end of puller plate.

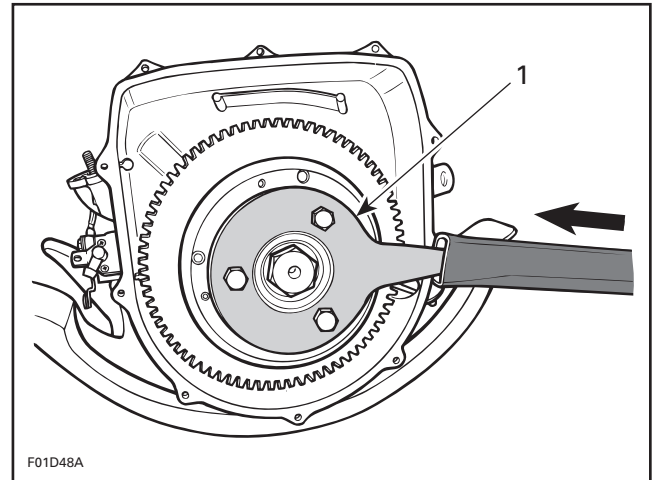

TYPICAL

1. Sleeves on opposite side

Using a suitable socket, unscrew retaining nut no. 6 COUNTERCLOCKWISE when facing it.

NOTE: If socket is found too large to be inserted in puller plate, machine or grind its outside diameter as necessary.

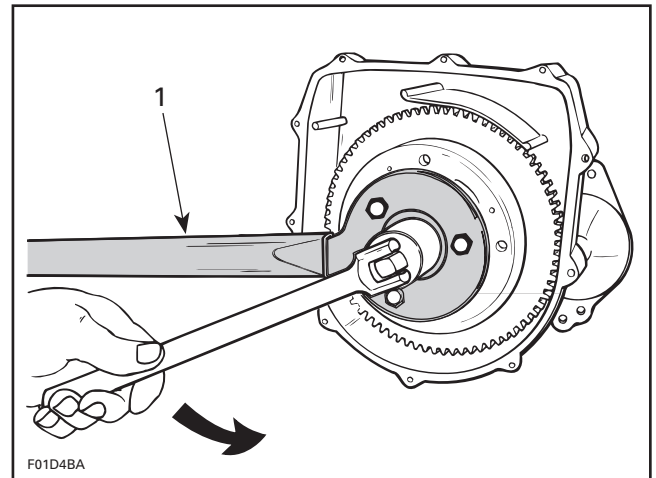

TYPICAL

1. Extension handle locking crankshaft

Remove nut and lock washer from magneto flywheel.

Magneto flywheel is easily freed from crankshaft with puller (P/N 295 000 106).

Section 03 ENGINE

Sub-Section 04 (MAGNETO SYSTEM)

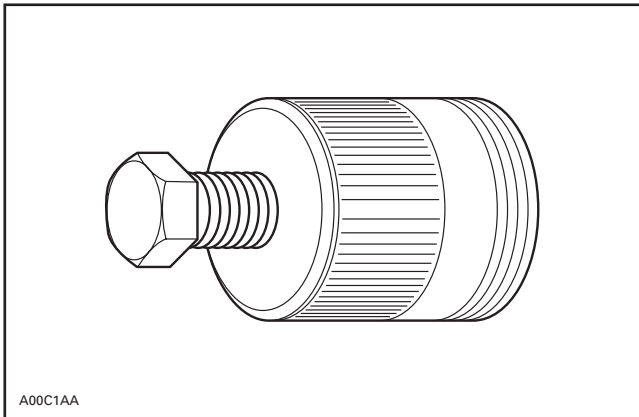

Fully thread on puller in puller plate.

Tighten puller bolt and at the same time, tap on bolt head using a hammer to release magneto fly-wheel from its taper.

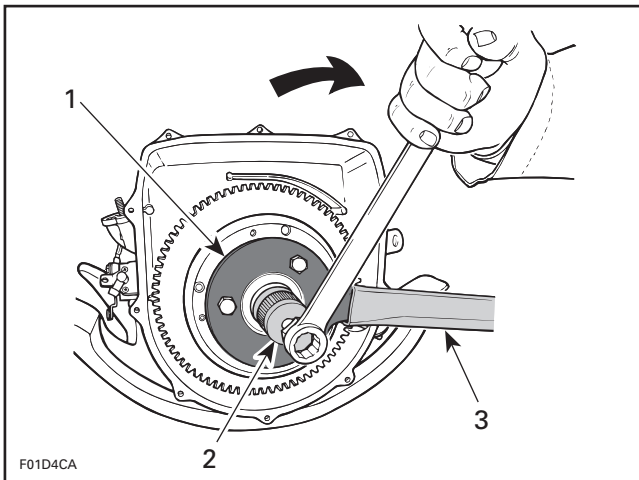

1. Puller plate
2. Puller
3. Extension handle

10, Armature Plate

Remove 3 retaining screws no. 15 and withdraw armature plate.

7, Magneto Housing

To remove magneto housing, starter has to be removed. Refer to ELECTRICAL SYSTEM 07-04.

Unscrew retaining screws no. 9, then withdraw housing.

Engine Crankcase Replacement

717 Engines

Since replacement crankcases do not have timing mark for armature plate location, indexing marks should be made on armature plate and crankcase to ease reassembly and further ignition timing.

The following procedure is to find a common reference point on both crankcases (old and new) to position armature plate.

Proceed as follows:

- Find a crankcase locating lug (the top one in this example).
- Place a cold chisel at the end of chosen lug, then punch a mark on armature plate at this point.

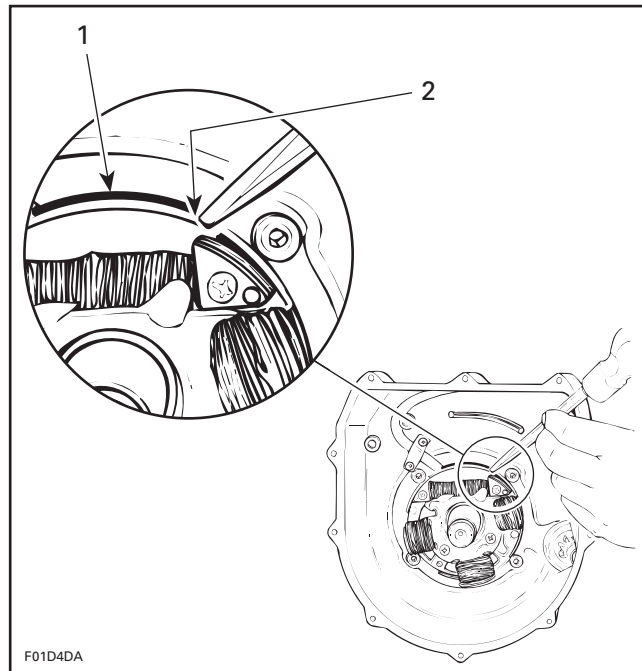

1. Crankcase locating lug
2. Mark armature plate at the end of lug

- At assembly, align armature plate mark (previously punched) with the end of the same locating lug on the new crankcase.

Section 03 ENGINE
Sub-Section 04 (MAGNETO SYSTEM)

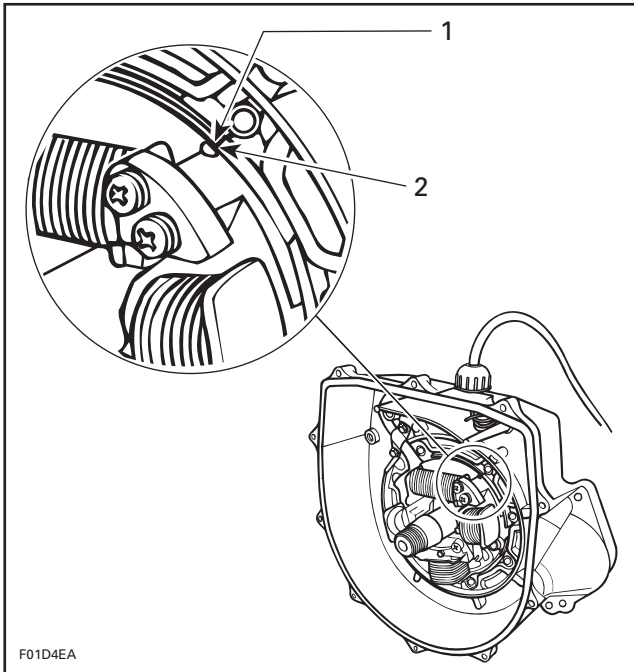

TYPICAL

1. Lug end of crankcase
2. Align mark and lug end here

– Find manufacturer's mark on armature plate. In line with this mark, punch another mark on adjacent crankcase lug.

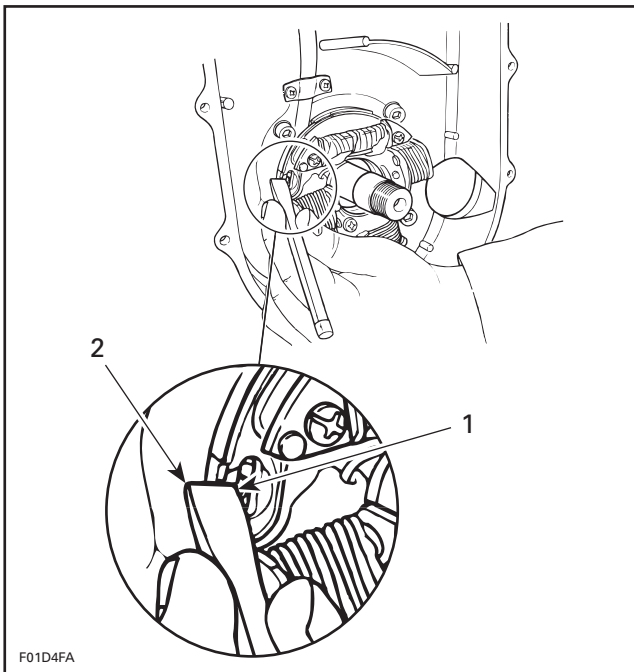

TYPICAL

1. Manufacturer's mark on armature plate
2. Punch a mark on crankcase lug aligned with plate mark

The new mark on crankcase will be used for further assembly positioning as a pre-timing position.

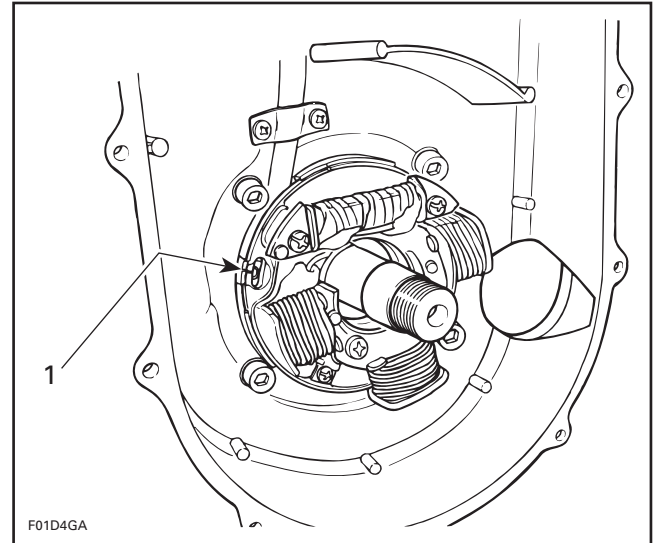

TYPICAL

1. For further assembly, use these marks

787 Engine

1, Magneto Housing Cover

Loosen screws no. 2. Remove engine magneto cover.

4,5, Rotor and Flywheel

Remove starter. Refer to ELECTRICAL SYSTEM 07-04.

Lock ring gear using special tool.

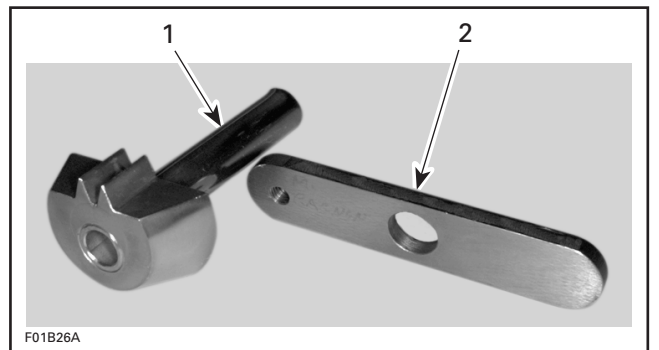

1. Ring gear blocking tool (P/N 295 000 134)
2. Retaining plate (P/N 295 000 154)

Section 03 ENGINE

Sub-Section 04 (MAGNETO SYSTEM)

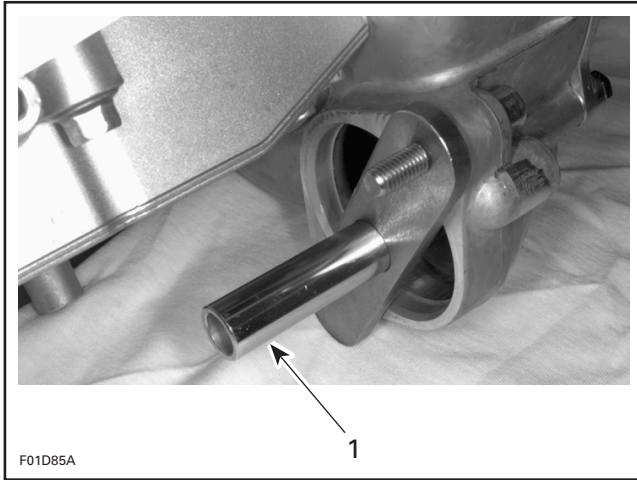

1. Ring gear blocking tool with retaining plate

If desired, magneto rotor can be removed without the engine flywheel. Remove the 6 screws no. 11.

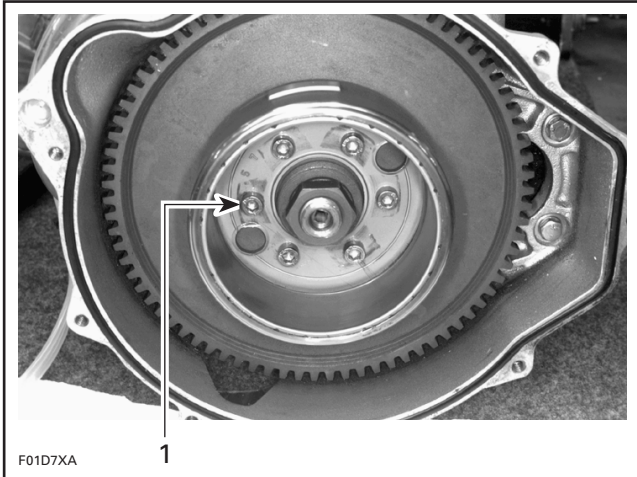

1. Screw

Using a suitable socket, unscrew retaining nut of engine flywheel COUNTERCLOCKWISE when facing it.

Remove special tool locking ring gear.

Engine flywheel is easily freed from crankshaft with puller (P/N 420 976 235) and crankshaft protective cap (P/N 290 876 557).

Insert crankshaft protector to outer end of crankshaft and fully thread puller in engine flywheel.

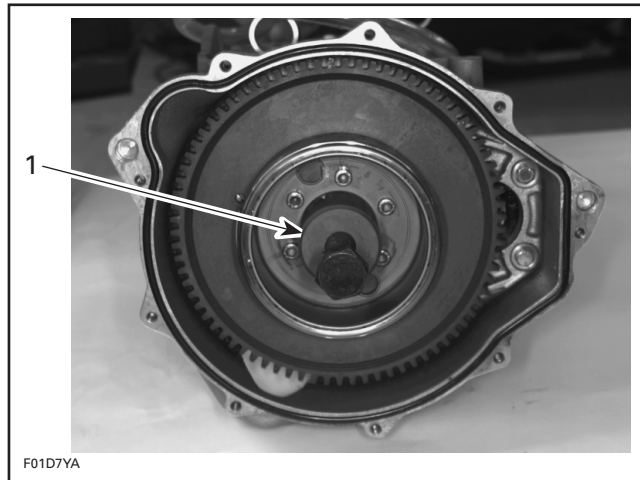

1. Puller

Tighten puller screw and at the same time, tap on screw head using a hammer to release engine flywheel from its taper.

CLEANING

Clean all metal components in a solvent.

▼ CAUTION

Clean coils and magnets using only a clean cloth.

Clean crankshaft taper and threads.

DISASSEMBLY

717 Engines

4,5, Magneto Flywheel and Ring Gear

Lay magneto flywheel on a steel plate. Tap lightly on ring gear using a hammer to release it from magneto flywheel.

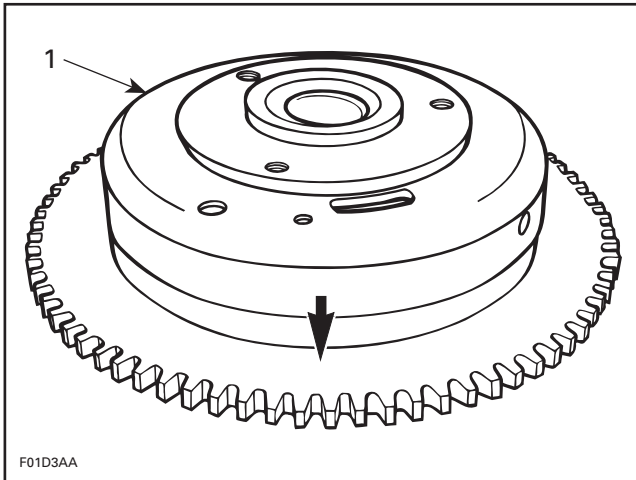

1. Magneto flywheel

11, Generating Coil

To replace generating coil:

- Heat the armature plate to 93°C (200°F) around the screw holes to break the threadlocker bond.

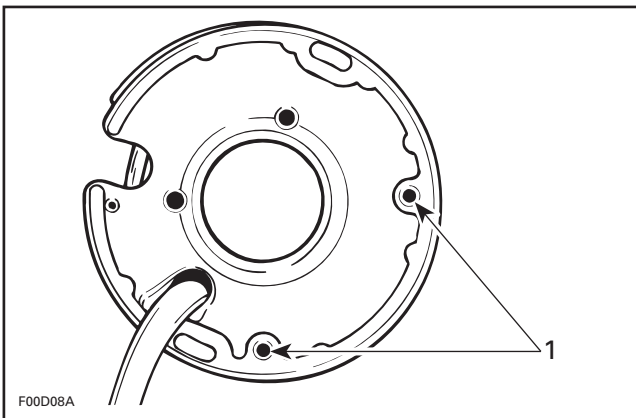

1. Heat the armature plate

▼ CAUTION

Protect harness from flame.

- Remove screws.
- Uncrimp and unsolder BLACK/RED wire from coil.

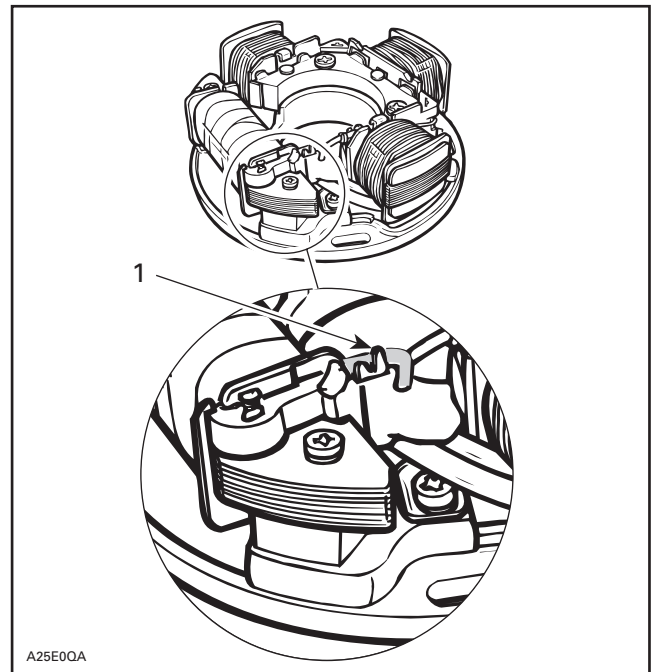

1. Uncrimp and unsolder wire here

13, Battery Charging Coil

To replace battery charging coil:

- Heat the armature plate to 93°C (200°F) around the screw holes to break the threadlocker bond.

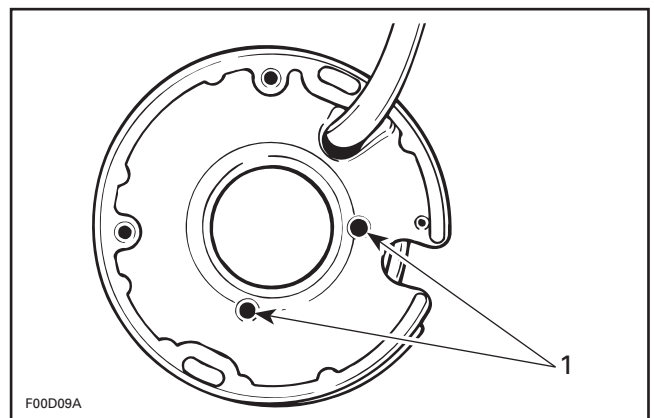

1. Heat the armature plate

▼ CAUTION

Protect harness from flame.

- Remove screws.
- Uncrimp and unsolder YELLOW and YELLOW/BLACK wires from coil.

Section 03 ENGINE

Sub-Section 04 (MAGNETO SYSTEM)

- Uncrimp and unsolder ground wire (BLACK) from coil core.

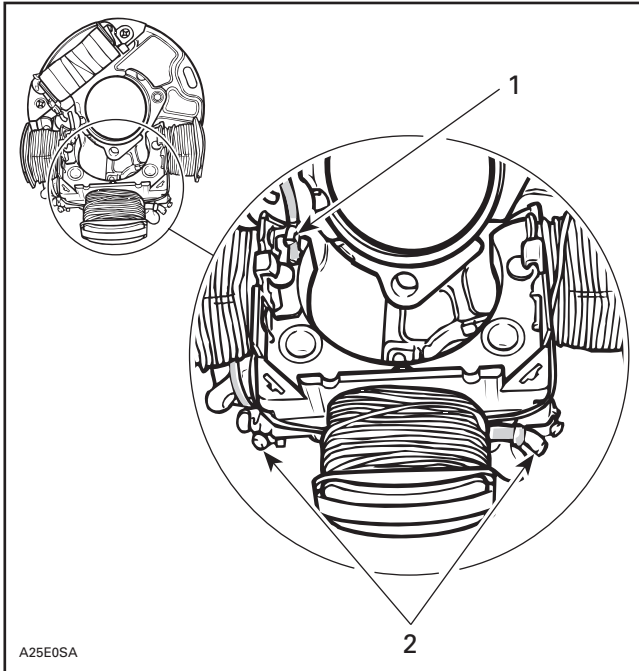

1. Uncrimp and unsolder ground wire (BLACK)
2. Uncrimp and unsolder YELLOW and YELLOW/BLACK wires

ASSEMBLY

717 Engines

11, Generating Coil

Strip end of old wire then crimp and solder on new coil.

Apply Loctite 242 (blue) to screws **no. 12** and install the new coil on armature plate.

Use magneto coil centering tool (P/N 290 876 922) and install so that it fits around armature plate before tightening screws.

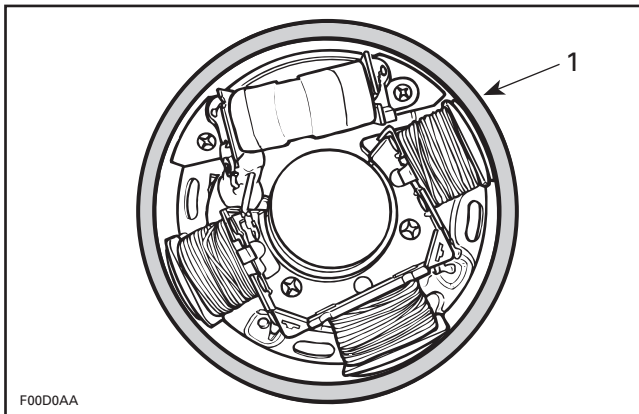

1. Magneto coil centering tool (P/N 290 876 922)

CAUTION

Before reinstalling the magneto, remove the loose epoxy from harness.

13, Battery Charging Coil

Position new coil, crimp and solder all wires.

Prior to assembly, apply Loctite 242 (blue).

Use magneto coil centering tool (P/N 290 876 922) and install it so that it fits around armature plate before tightening screws **no. 14**.

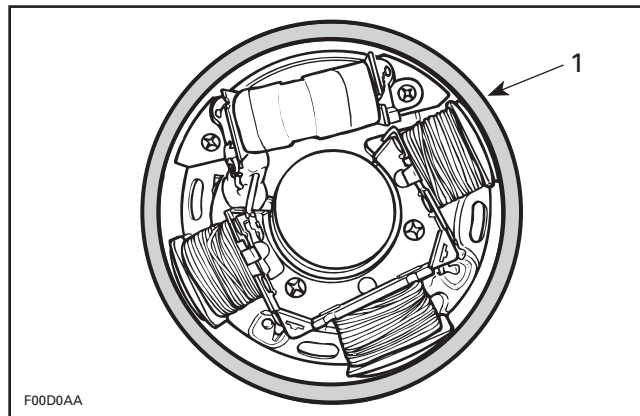

1. Magneto coil centering tool (P/N 290 876 922)

4,5, Magneto Flywheel and Ring Gear

Apply Loctite 648 (green) to magneto flywheel mating surface. Lay ring gear on a steel plate, then heat with a propane torch in order to install it on magneto flywheel.

Pay particular attention to position ring gear teeth chamfer side as per following illustration.

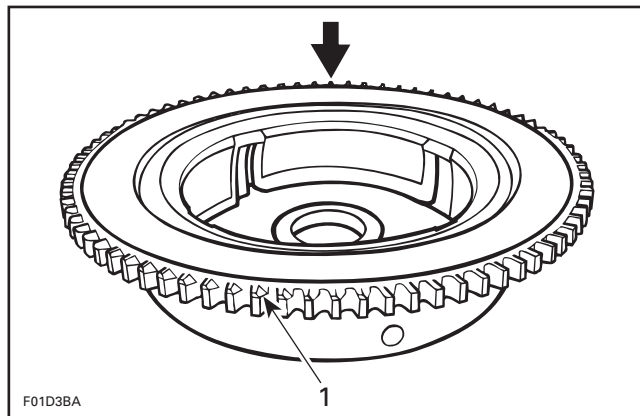

1. Teeth chamfer

NOTE: Ensure that ring gear contacts magneto flywheel flange.

Whenever replacing either ring gear or magneto flywheel, Gun Kote must be applied to prevent possible corrosion.

▼ CAUTION

Always assemble magneto flywheel and ring gear prior to apply Gun Kote. If not done correctly, ring gear won't contact magneto flywheel flange.

To apply Gun Kote proceed as follows:

1. Clean thoroughly and degrease replacement part using a non oil base solvent.
2. Apply coating in light thin coats using a spray gun.

NOTE: Do not spray Gun Kote into magneto flywheel threaded holes.

3. Bake parts in oven at 175° (350°F) for one hour to cure Gun Kote.

▼ CAUTION

Do not eliminate Gun Kote heat curing time because it will lose all its resistance and it will not give any protection.

787 Engine

12, Stator

Install the stator in magneto housing cover **no. 1** and torque screws **no. 13** to 10 N•m (88 lbf•in).

Replace wiring harness bracket **no. 16** of stator and torque screws to 4.5 N•m (40 lbf•in).

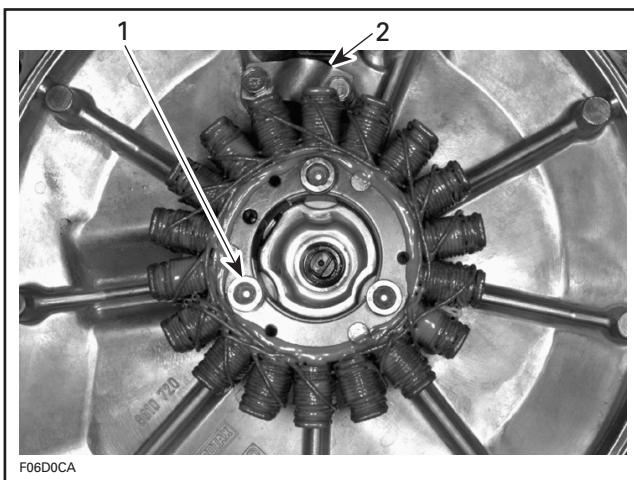

1. Stator screws
2. Bracket

14, Trigger Coil

Install the trigger coil in magneto housing cover **no. 1** and torque screws **no. 15** to 10 N•m (88 lbf•in).

NOTE: The trigger coil is not adjustable.

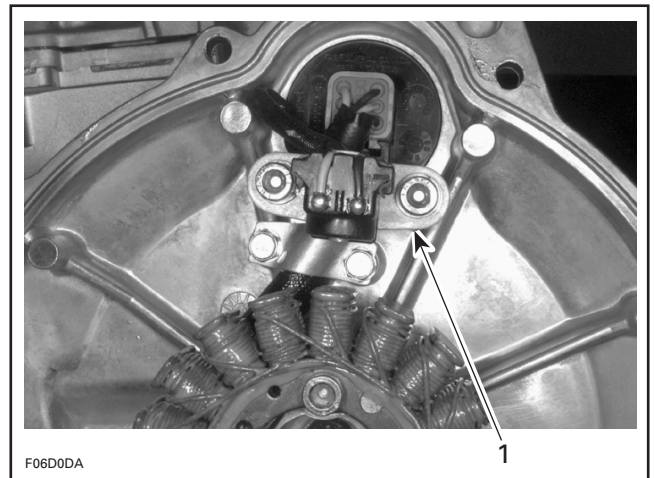

1. Trigger coil

INSTALLATION

717 Engines

7, Magneto Housing

Install gasket **no. 8** between magneto housing and engine crankcase.

Install magneto housing and torque screws **no. 9** to 9 N•m (80 lbf•in).

10, Armature Plate

Position the armature plate on the crankcase, aligning the marks on both parts.

Apply a drop of Loctite 242 (blue) on threads of screws **no. 15** and torque to 6 N•m (53 lbf•in).

4, Magneto Flywheel

Apply Loctite 242 (blue) on crankshaft taper.

Position Woodruff key **no. 16** and magneto flywheel. Apply Loctite 242 (blue) on nut **no. 6**. Install nut with lock washer and torque to 145 N•m (107 lbf•ft).

▼ CAUTION

Never use any type of impact wrench at magneto installation.

Section 03 ENGINE

Sub-Section 04 (MAGNETO SYSTEM)

Ignition Timing

For ignition timing procedures of 717 engines, refer to ELECTRICAL SYSTEM 07-02.

787 Engine

7, Magneto Housing

To install oil seal no. 10 of magneto housing, use pusher (P/N 290 877 740) and handle (P/N 290 877 650).

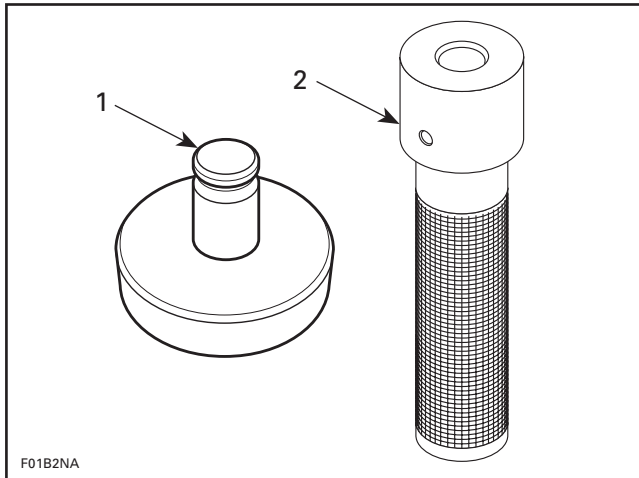

1. Pusher
2. Handle



Install gasket no. 8 between magneto housing and engine crankcase.

Install magneto housing and torque screws no. 9 to 9 N•m (80 lbf•in).

4,5, Rotor and Flywheel

When reinstalling magneto rotor to engine flywheel, apply Loctite 648 to mating surfaces.

One of the protuberance end of magneto rotor must align with hole of engine flywheel.

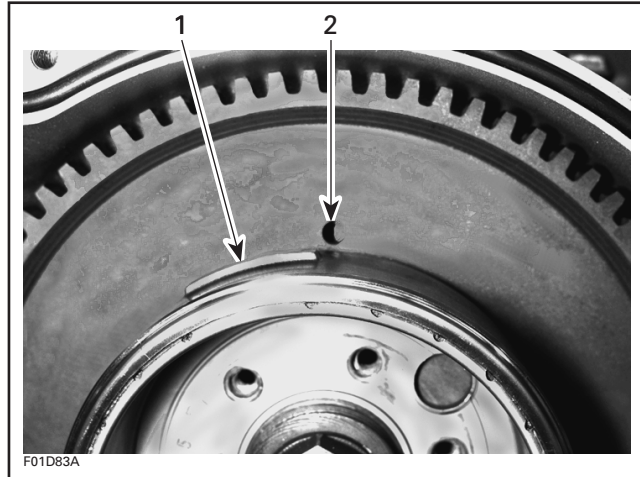

1. Protuberance
2. Hole

Apply Loctite 648 (green) on screws no. 11 and torque to 10 N•m (88 lbf•in).

Apply Loctite 242 (blue) on crankshaft taper.

Apply Loctite 242 (blue) on nut no. 6. Install nut with lock washer and torque to 105 N•m (77 lbf•ft).

▼ CAUTION

Never use any type of impact wrench at magneto installation.

All Engines

1, Magneto Housing Cover

Properly install O-ring no. 3 in magneto housing. Apply Loctite 767 anti-seize on screws no. 2, install cover, wire supports no. 17 and no. 18 (717 engines) then torque screws no. 2 in a criss-cross sequence to 9 N•m (80 lbf•in).

TOP END

717 Engines

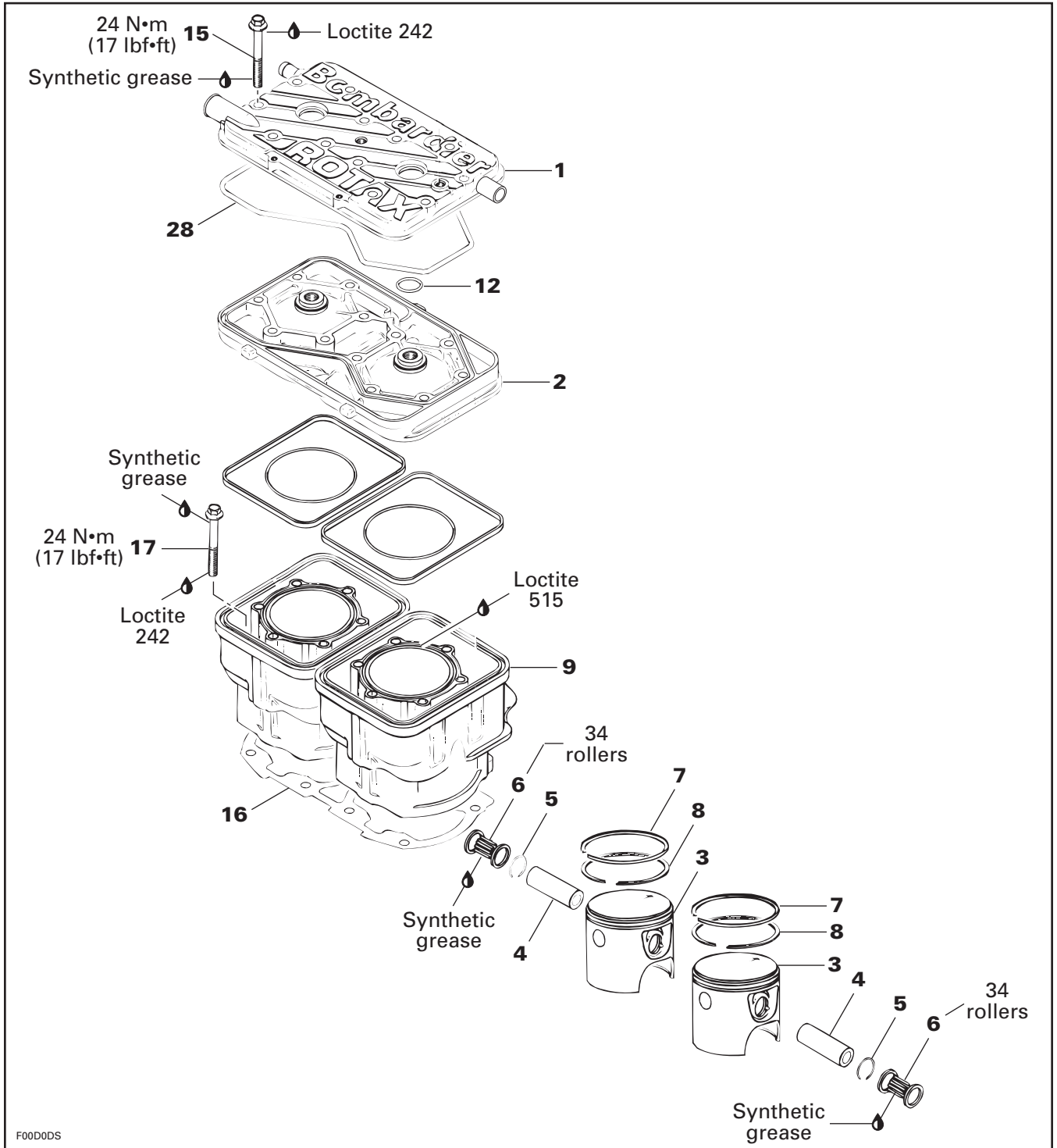

Section 03 ENGINE

Sub-Section 05 (TOP END)

787 Engine

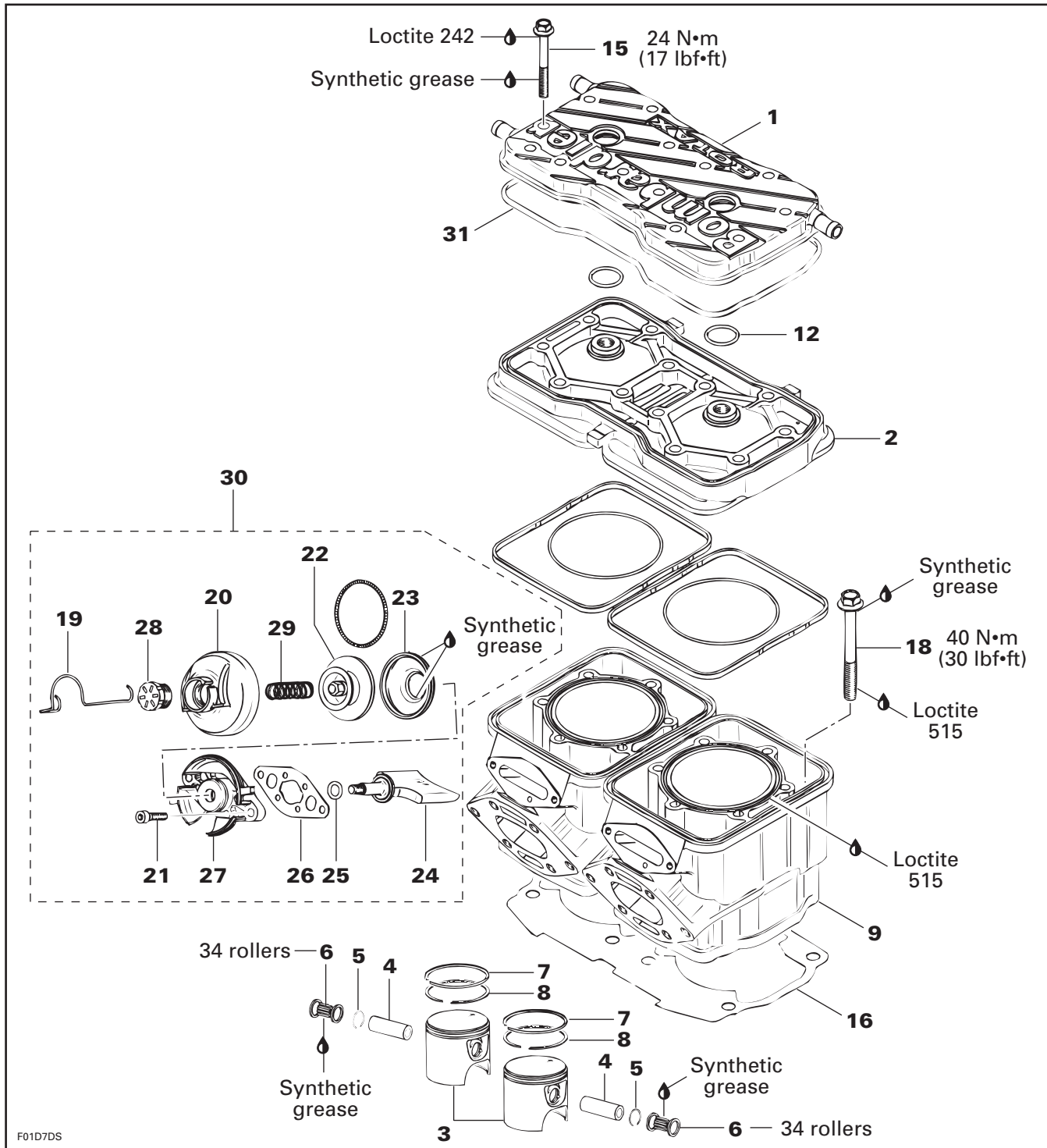

F01D7DS

GENERAL

The 2-stroke ROTAX engine rotates counterclockwise seen from the rear (PTO flywheel). It has a rotary valve to control opening and closing of intake.

▼ CAUTION

No engine components can be interchanged between engines.

787 Engine Only

This engine is canted at a 30 degree angle, lowering the center of gravity of the watercraft. Cylinder exhaust ports are located on the same side of the intake, allowing a high volume tuned pipe design. This engine also features the RAVE system (Rotax Adjustable Variable Exhaust). The RAVE system working in combination with the high volume tuned pipe offers a broader power band.

RAVE System

THEORY

For a 2-stroke-cycle engine to have high power capacity at high crankshaft speeds, a high volumetric or breathing efficiency is required and the fresh charge losses must be minimized. The result is achieved by opening the exhaust port early and utilizing the resonant effects of the tuned exhaust system to control fresh charge losses.

When an engine of this design is run at a medium speed, efficiency falls off quickly. The relatively high exhaust port effectively shortens the useful power stroke and because the exhaust system is tuned for maximum power, there is a large increase of fresh charge losses. As a result, the torque decreases along with a dramatic increase of the specific fuel consumption. Higher torque along with lower fuel consumption can be obtained at lower engine speeds if the time the exhaust port is open is shortened.

Bombardier-Rotax has patented a remarkably simple system to automatically change the exhaust port height based on pressure in the exhaust system.

Located above the exhaust port is a guillotine-type slide valve. This rectangular valve is connected by a shaft to a diaphragm which is working against the return spring. One small passage in the cylinder just outside the exhaust port allows exhaust gas pressure to reach the diaphragm.

To the outside of the return spring is a red plastic adjustment knob. Turning the adjustment in or out changes the preload on the return spring which, in turn, will change the RPM at which the RAVE valve opens and closes.

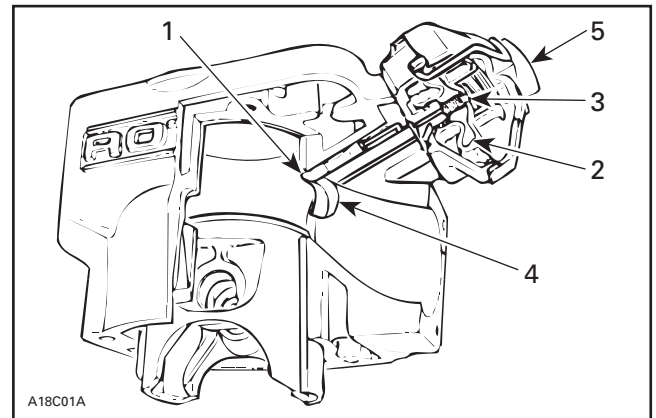

TYPICAL

1. Sliding valve
2. Diaphragm
3. Spring
4. Exhaust port
5. Adjustment knob

As the throttle is opened and the engine begins producing more power, the pressure against the diaphragm will overcome the pressure of the return spring and the RAVE valve will open.

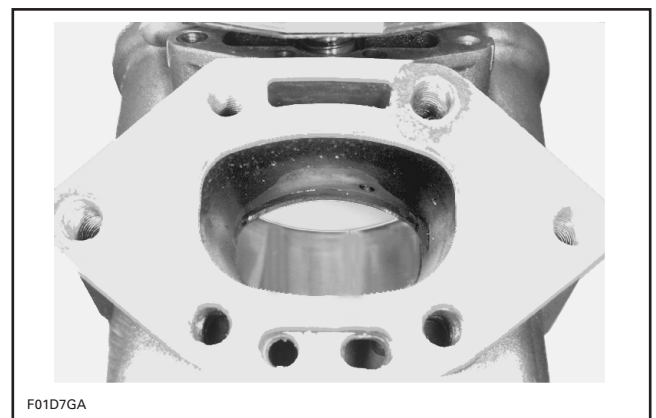

VALVE FULLY OPENED

Section 03 ENGINE

Sub-Section 05 (TOP END)

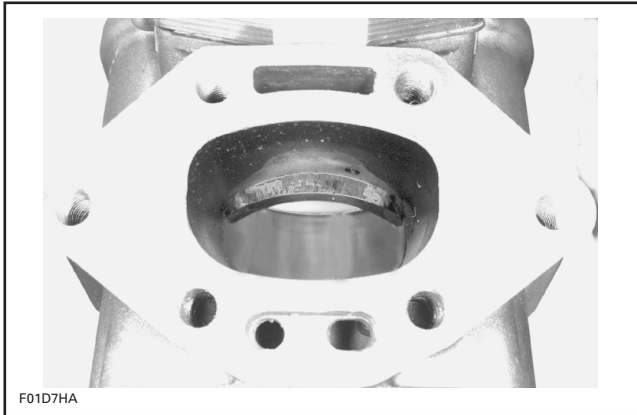

VALVE FULLY CLOSED

The RAVE valve does not allow an engine to make higher peak horsepower than an engine not so equipped, it can make moving the peak higher practical because of its effect on the rest of the power curve. Item 2 in the following figure is the power curve of an engine with the RAVE valve held fully open through its entire RPM range. Item 6 notes the peak power produced. That peak will not change if the exhaust port time of a similar engine without a RAVE valve was the same (with all other features equal).

Item 1 is the power curve of the engine with the RAVE valve closed through its entire RPM range. The shaded area (item 3) is the improvement in power at lower engine speeds that is gained because of the lower exhaust port. If the port remains at this height, however, the power would peak as noted in item 5. Raising the exhaust port at the proper RPM (item 7) will allow the engine peak power to continue to rise (item 6).

Item P1 in figure is the force of the return spring against the diaphragm. The exhaust pressure must be high enough to overcome this force before the valve begins opening. Item P2 is the pressure required to completely open the RAVE valve. Between P1 and P2, the usable power curve of the engine is moving from power curve 1 to power curve 2. This transition takes place very rapidly at full throttle and from a practical standpoint can be considered to be instantaneous at item 7. Gradual application of the throttle, however, will result in the RAVE valve opening much later.

If the RAVE valve opens too late, the engine will bog or hesitate momentarily as the RPM increases. Full peak performance (item 6) is still available. From a functional point of view. It is better to have the valve open a bit early than a bit late.

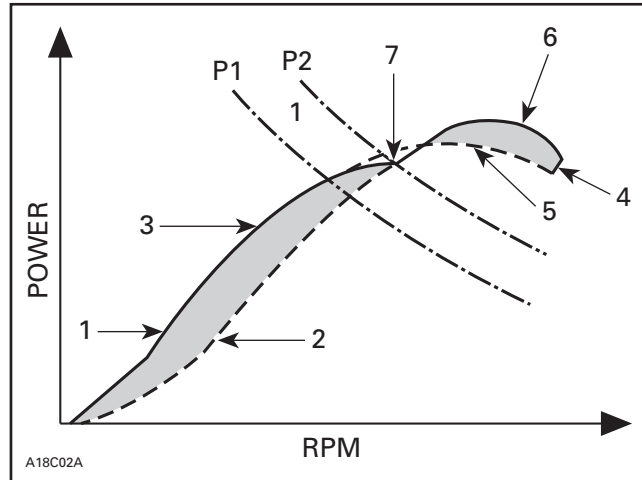

MAINTENANCE

There are no wear parts anywhere in the system and there are no adjustments to be periodically checked. The only possible maintenance required would be cleaning of carbon deposits from the guillotine slide. Cleaning intervals would depend upon the user's riding style and the quality of the oil used. Using FORMULA XP-S synthetic injection oil, we would suggest annual cleaning of the valve. If a customer uses a lower quality oil, more frequent cleaning may be required.

No special solvents or cleaners are required when cleaning the valve.

BORING PRECAUTION

In its stock configuration the RAVE valve guillotine has a minimum of 0.5 mm (.020 in) clearance to the cylinder bore measured at the center line of the cylinder. This is the minimum production clearance.

There is only a first oversize piston available for the 787 engine. That piston is 0.25 mm (.010 in) larger in diameter than the stock piston. When the oversize is installed, the guillotine will have a minimum clearance of 0.375 mm (.015 in) with the cylinder bore. This is the minimum operating clearance the guillotine should be used with. Clearance less than 0.375 mm (.015 in) will require reworking of the guillotine to achieve the proper clearance and radius.

DISASSEMBLY

787 Engine

30, RAVE Valve

Remove the cover no. 20 of the valve by releasing the spring no. 19.

◆ WARNING

Firmly hold cover to valve base. The spring inside the valve is applying a pressure against the cover.

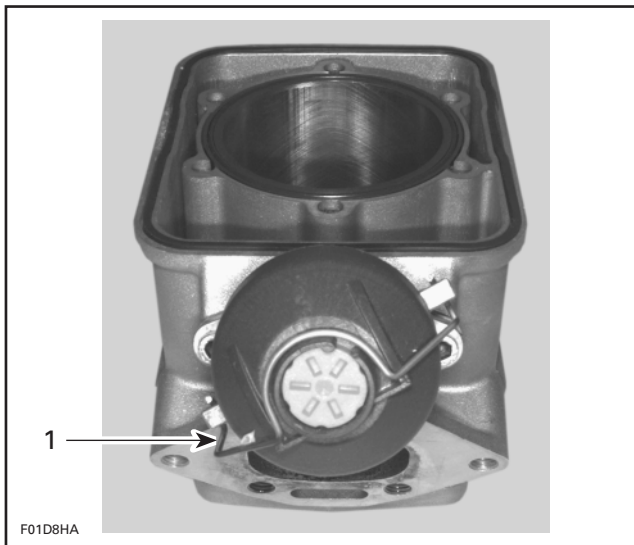

1. Spring

Loosen Allen screws no. 21 and remove RAVE valve.

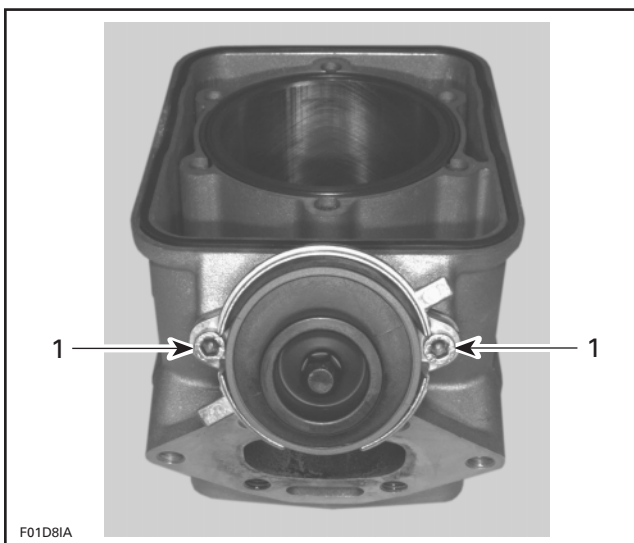

1. Allen screws

Remove bellow no. 23 from valve piston no. 22. Unscrew valve piston no. 22 from sliding valve no. 24.

NOTE: Hold the sliding valve to prevent it from turning.

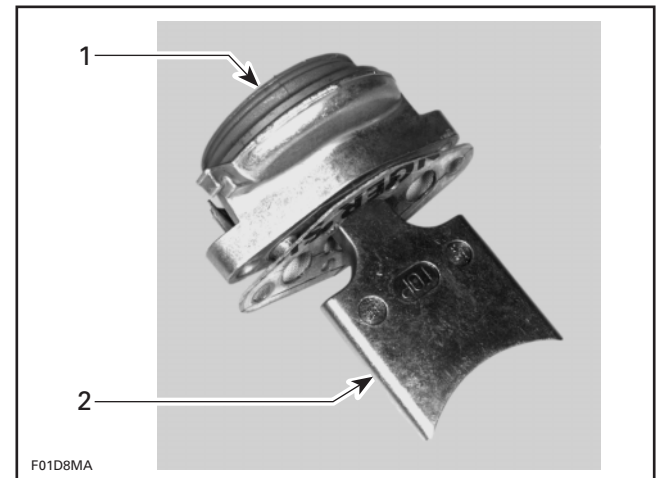

1. Unscrew piston
2. Hold sliding valve

All Engines

1,2, Cylinder Head Cover and Cylinder Head

Disconnect temperature sensor wire and spark plug cables.

Connect spark plug cables on grounding device.

717 Engines

Remove air intake silencer and support, refer to FUEL SYSTEM 05-03.

All Engines

Remove screws no. 15.

Remove cylinder head cover no. 1.

If shells, sand, salt or any other particles are present in cylinder head, clean with a vacuum cleaner.

Remove cylinder head no. 2.

If shells, sand, salt water or any other particles are present in cylinder cooling jacket, clean with a vacuum cleaner.

9, Cylinder

787 Engine

Remove air intake silencer and support, refer to FUEL SYSTEM 05-03.

Section 03 ENGINE

Sub-Section 05 (TOP END)

All Engines

Remove tuned pipe and exhaust manifold, refer to ENGINE 03-08.

Remove screws no. 17.

Remove cylinders, being careful that connecting rods do not hit crankcase edge.

◆ WARNING

If screws need to be heated for removal when engine is in watercraft, fuel system pressurization must be done first. Do not use open flame; use a heat gun.

NOTE: Even if only one cylinder needs repair, both cylinders should be lifted to allow 1-piece cylinder base gasket replacement.

3, Piston

NOTE: The 717 and 787 engines feature cageless piston pin bearings.

Bring piston to Top Dead Center and install rubber pad (P/N 295 000 101) over crankcase opening. Secure with screws. Lower piston until it sits on pad.

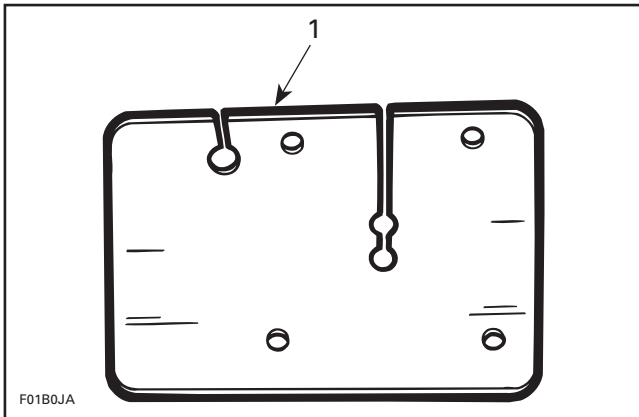

1. Rubber pad

If the other cylinder has been removed, completely cover its opening with a clean rag.

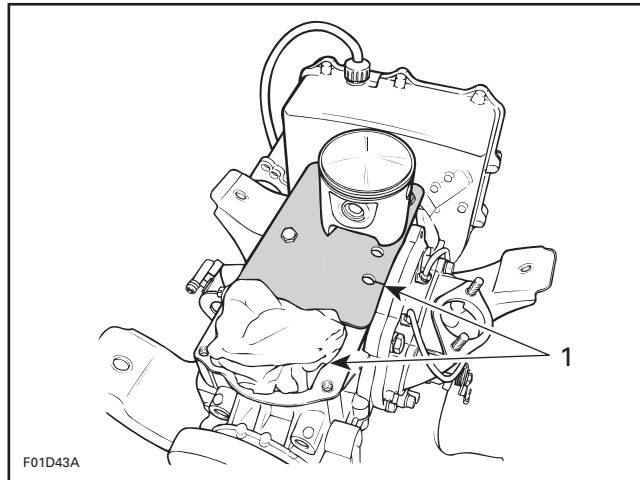

1. Openings covered with rag and rubber pad

To remove circlip no. 5, insert a pointed tool in piston notch then pry it out and discard.

◆ WARNING

Always wear safety glasses when removing piston circlips.

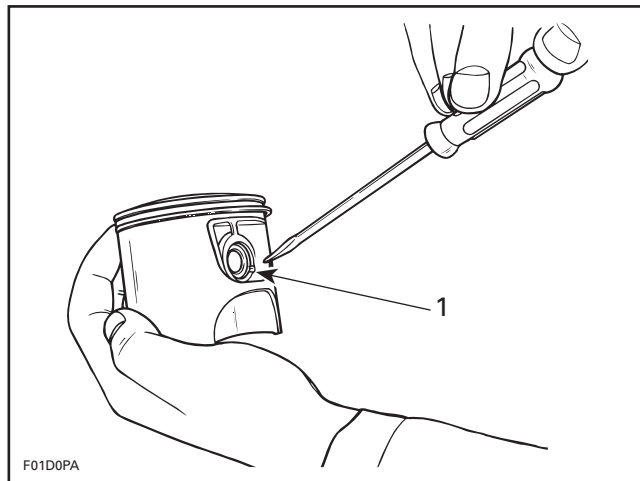

TYPICAL

1. Piston notch

To extract piston pin no. 4, use piston pin puller (P/N 290 877 092) as follows:

- Fully thread on puller handle.
- Insert extractor spindle into the piston pin.
- Slide the expansion sleeve (P/N 290 877 041) onto the spindle.
- Screw in extracting nut (P/N 290 877 155) with the movable extracting ring towards spindle.

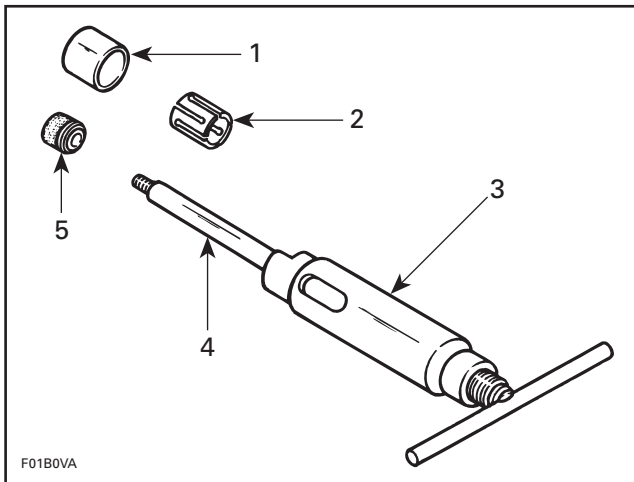

PISTON PIN PULLER (P/N 290 877 092)

1. Bushing (P/N 290 877 181)
2. Expansion sleeve (P/N 290 877 041)
3. Extractor sleeve
4. Extractor spindle
5. Extracting nut (P/N 290 877 155)

- Firmly hold puller and rotate handle to pull piston pin **no. 4**.

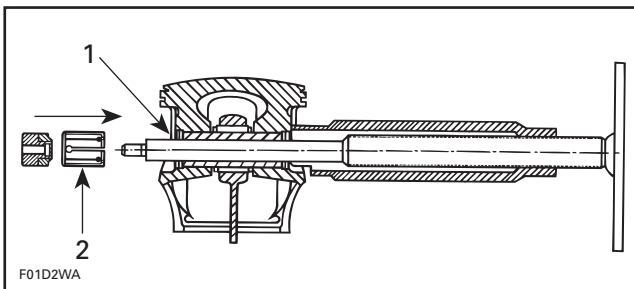

1. Circlip at this side not to be removed
2. Grease expansion sleeve

- By turning the spindle, pull out piston pin until it is completely removed from bearing.

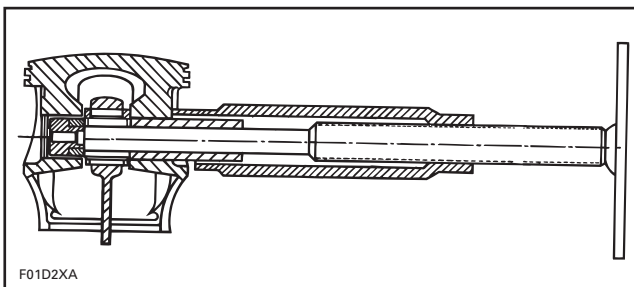

- Rotate spindle until extracting nut can be removed.
- Remove spindle and extractor sleeve from piston pin **no. 4**.
- Carefully remove the piston **no. 3**.

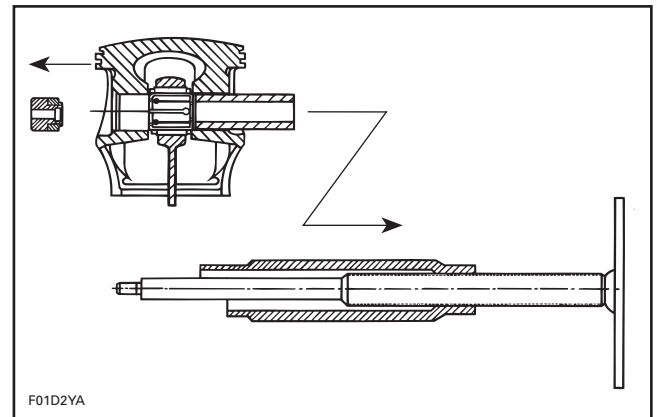

- The needles, thrust washers and the expansion sleeve remain in the connecting rod bore and may be used again.

To remove rollers with the thrust washers from the connecting rod bore, push them together with the expansion sleeve into the bushing (P/N 290 877 181) using any suitable 23 mm (.905 in) diameter pusher.

▼ CAUTION

Recover rollers, make sure that 34 rollers are found for each piston.

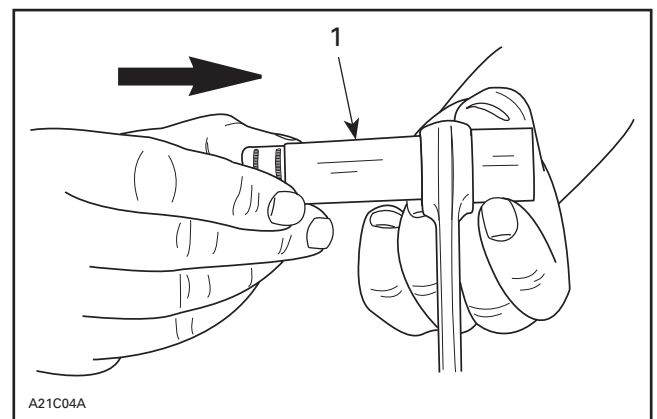

1. Pusher 23 mm (.905 in)

CLEANING

- Discard all gaskets and O-rings.
- Clean all metal components in a solvent.
- Clean water passages and make sure they are not clogged.
- Remove carbon deposits from cylinder exhaust port, RAVE valve (787 engine), cylinder head and piston dome.

Section 03 ENGINE

Sub-Section 05 (TOP END)

Clean piston ring grooves with a groove cleaner tool, or a piece of broken ring.

INSPECTION

787 Engine

Check RAVE valve bellow no. 23 for cracks.

Check if passages of valve housing no. 27 and cylinder no. 9 are not obstructed.

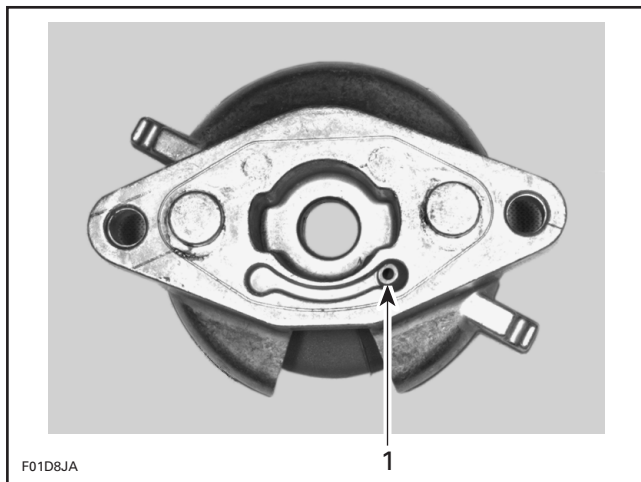

1. Passage of valve housing

All Engines

Visually inspect all parts for corrosion damage.

Inspect piston for damage. Light scratches can be sanded with a fine sand paper.

NOTE: When repairing a seized engine, connecting rods should be checked for straightness and crankshaft for deflection/misalignment. Refer to ENGINE 03-06 for procedures.

Inspect plane surfaces for warpage. Small deformation can be corrected by grinding surface with a fine sand paper. Install sand paper on a surface plate and rub part against oiled sand paper.

The inspection of engine top end should include the following measurements.

ENGINE MEASUREMENT	TOLERANCES		
	NEW PARTS (min.) (max.)		WEAR LIMIT
Cylinder Taper	N.A.	0.05 mm (.002 in)	0.1 mm (.004 in)
Cylinder Out of Round	N.A.	0.008 mm (.0003 in)	0.08 mm (.003 in)
Piston/Cylinder Wall Clearance for 717 Engines	0.06 mm (.0024 in)	0.11 mm (.004 in)	0.20 mm (.008 in)
Piston/Cylinder Wall Clearance for the 787 Engine	0.10 mm (.004 in)	0.12 mm (.005 in)	0.20 mm (.008 in)
Ring/Piston Groove Clearance	0.03 mm (.001 in)	0.07 mm (.003 in)	0.20 mm (.008 in)
Ring End Gap	0.25 mm (.010 in)	0.40 mm (.016 in)	1.0 mm (.039 in)

N.A.: Not Applicable

NOTE: Replacement cylinder sleeves are available if necessary. Also, oversize pistons of 0.25 mm (.010 in) are available for all engines and oversize pistons of 0.5 mm (.020 in) are available for 717 engines.

Cylinder Taper

Using a cylinder bore gauge, measure cylinder diameter at 16 mm (5/8 in) from top of cylinder just below auxiliary transfer port, facing exhaust port. If the difference between readings exceed specification, cylinder should be rebored and honed or replaced.

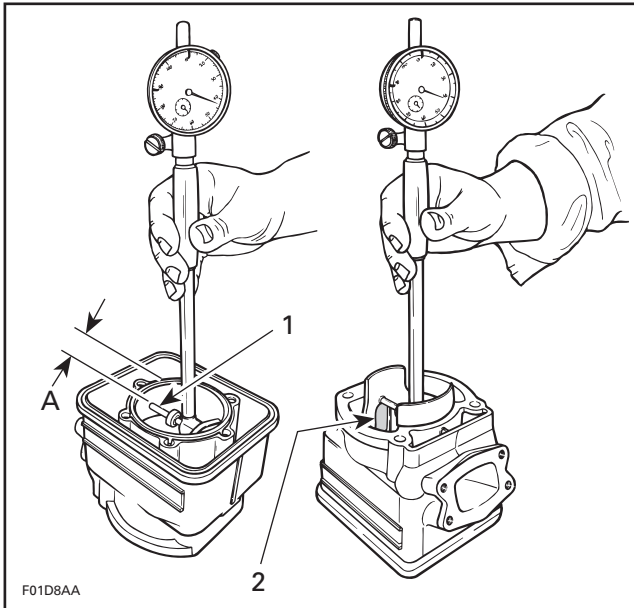

1. Measuring perpendicularly (90°) to piston pin axis
2. Auxiliary transfer port
- A. 16 mm (5/8 in)

Cylinder Out of Round

Using a cylinder bore gauge, measure cylinder diameter at 16 mm (5/8 in) from top of cylinder. Measure diameter in piston pin axis direction then perpendicularly (90°) to it. If the difference between readings exceed specification, cylinder should be rebored and honed or replaced.

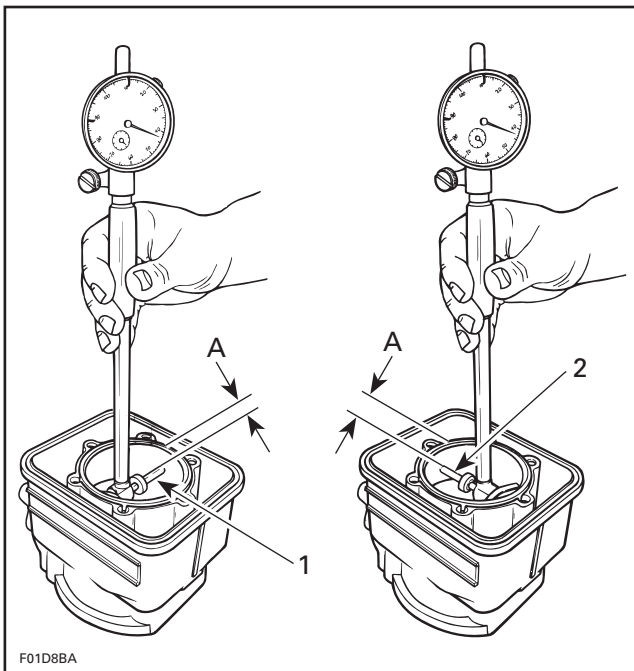

1. Measuring in piston pin axis
2. Measuring perpendicularly (90°) to piston pin axis
- A. 16 mm (5/8 in)

Piston/Cylinder Wall Clearance

PISTON MEASUREMENT

Used Piston

Using a micrometer, measure piston at 25 mm (1 in) from skirt end perpendicularly (90°) to piston pin.

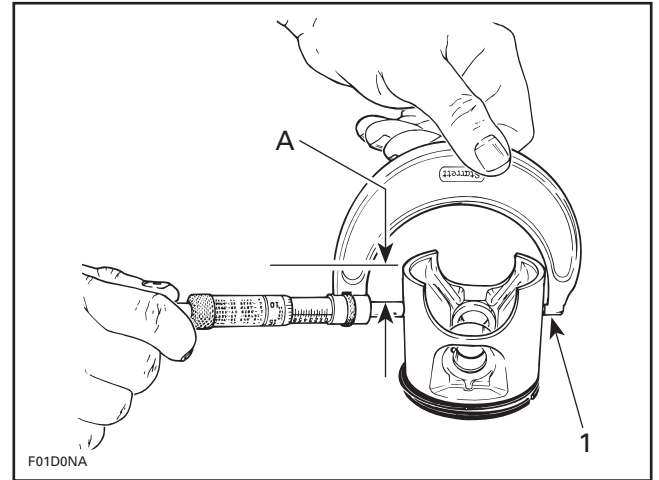

1. Measuring perpendicularly (90°) to piston pin axis
- A. 25 mm (1 in)

Lock the micrometer to the obtained value.

New Piston

To determine the piston dimension, take the measurement on the piston dome.

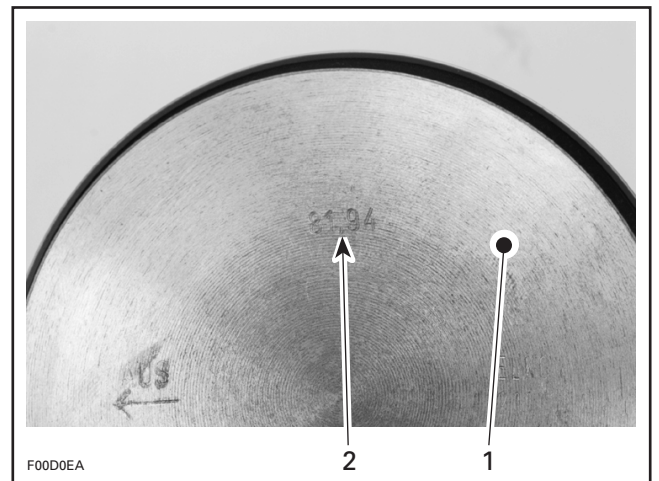

1. Piston dome
2. Piston measurement

Adjust and lock a micrometer to the specified value on the piston dome.

Section 03 ENGINE

Sub-Section 05 (TOP END)

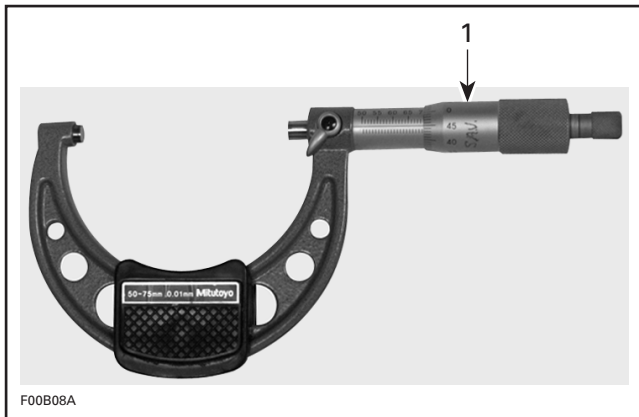

1. Micrometer set to the piston dimension

PISTON/CYLINDER WALL CLEARANCE MEASUREMENT

Used and New Pistons

With the micrometer set to the piston dimension, adjust a cylinder bore gauge to the micrometer dimension and set the indicator to zero.

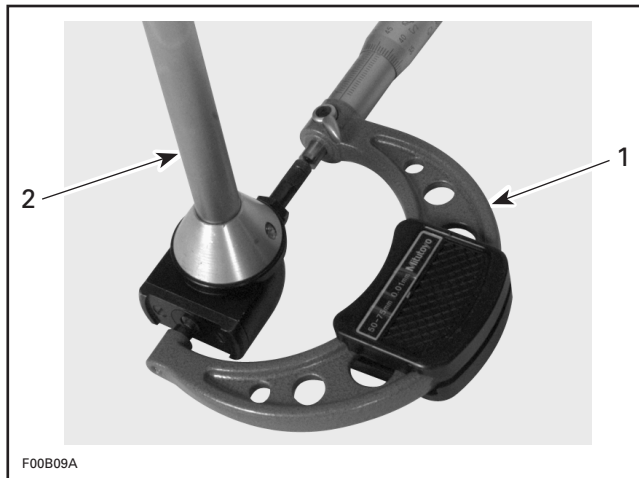

1. Use the micrometer to set the cylinder bore gauge
2. Dial bore gauge

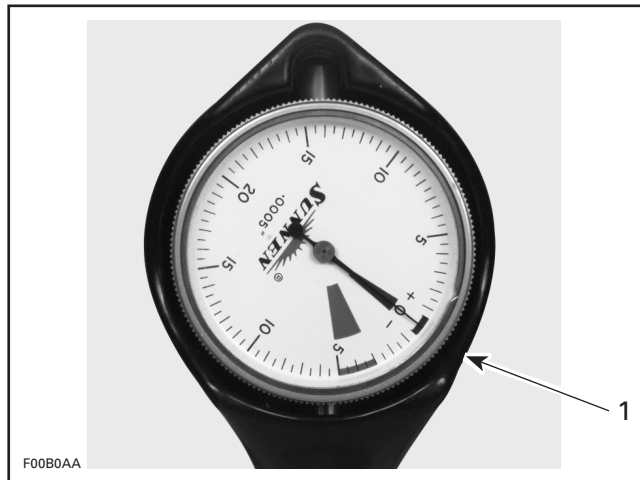

1. Indicator set to zero

Position the dial bore gauge at 16 mm (5/8 in) below cylinder top edge.

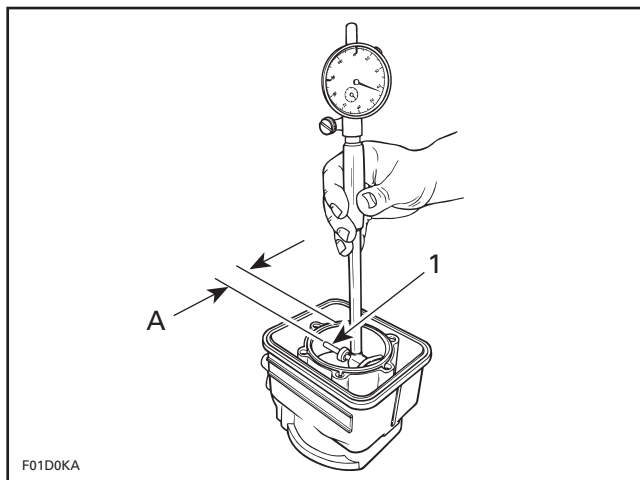

1. Measuring perpendicularly (90°) to piston pin axis
A. 16 mm (5/8 in)

Read the measurement on the cylinder bore gauge. The result is the exact piston/cylinder wall clearance.

NOTE: Make sure the cylinder bore gauge indicator is set exactly at the same position as with the micrometer, otherwise the reading will be false.

Ring/Piston Groove Clearance

Using a feeler gauge, check clearance between rectangular ring and groove. If clearance exceeds specified tolerance, replace piston.

NOTE: Ring/piston groove clearance can be correctly measured only on rectangular ring which is bottom ring.

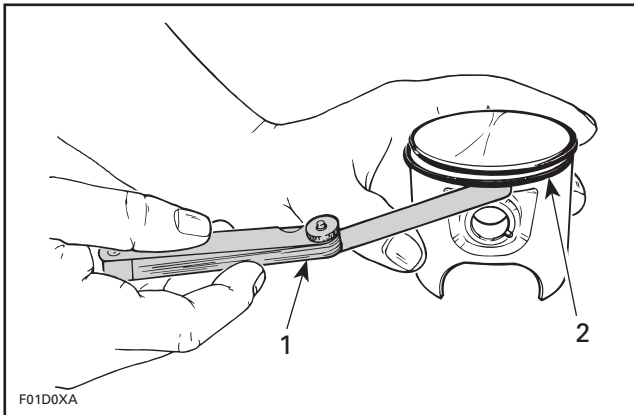

1. Feeler gauge
 2. Rectangular ring (bottom)

Ring End Gap

Position ring halfway between exhaust port and top of cylinder.

NOTE: In order to correctly position ring in cylinder, use piston as a pusher.

Using a feeler gauge, check ring end gap. If gap exceeds specified tolerance, rings should be replaced.

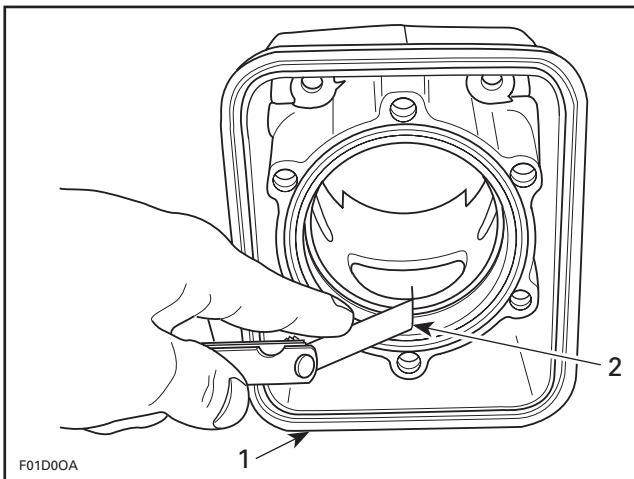

1. Top of cylinder
 2. Ring end gap

16, Cylinder Base Gasket

Five thicknesses of cylinder base gaskets are available for a precise adjustment of the combustion chamber volume.

To determine gasket thickness, refer to the identification holes on the gasket.

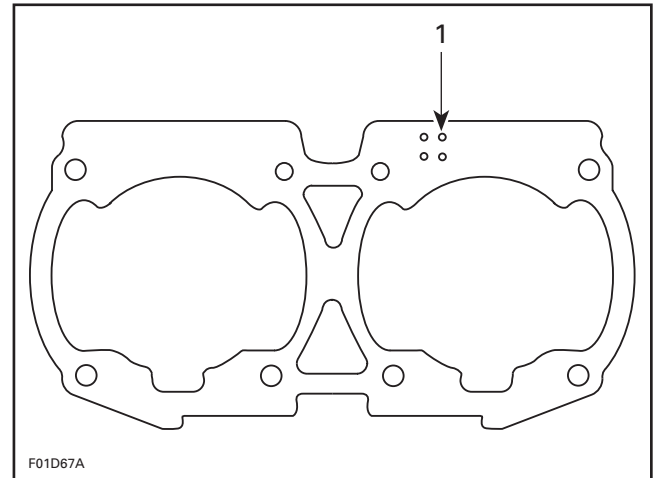

1. Identification holes

GASKET THICKNESS	IDENTIFICATION HOLES
0.3 mm (.012 in)	3
0.4 mm (.016 in)	4
0.5 mm (.020 in)	5
0.6 mm (.024 in)	6
0.8 mm (.031 in)	8

ASSEMBLY

Assembly is essentially the reverse of disassembly procedures. However pay particular attention to the following.

787 Engine

30, RAVE Valve

Make sure to insert O-ring no. 25 onto rod of sliding valve no. 24.

The TOP position of the sliding valve no. 24 is indicated on one side.

Section 03 ENGINE

Sub-Section 05 (TOP END)

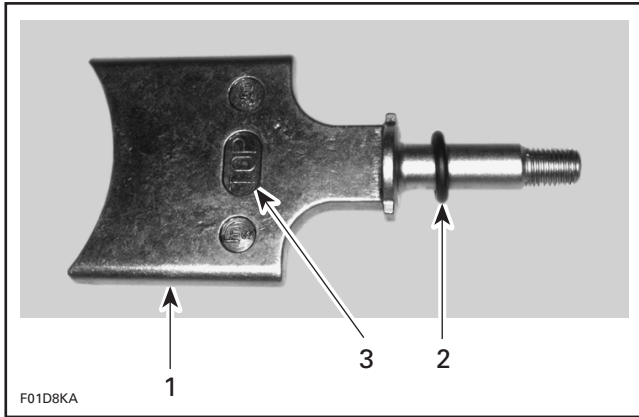

1. Sliding valve
2. O-ring
3. "TOP"

Install a new gasket no. 26. It must be installed at the same time as the sliding valve no. 24.

Position the valve housing no. 27 onto the cylinder so that its opening is toward the bottom.

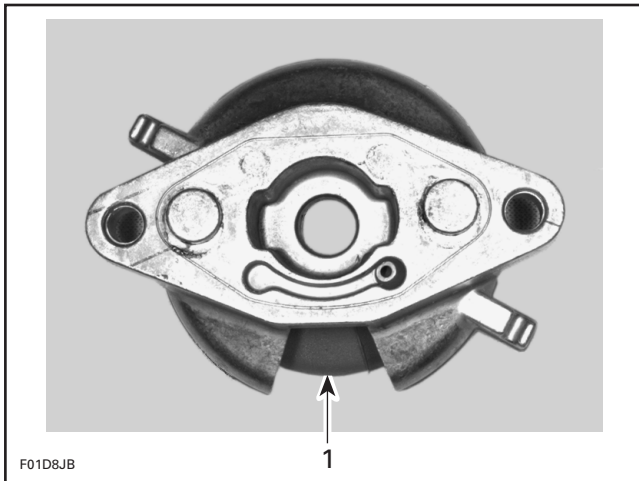

1. Bottom of valve housing

When the valve is mounted onto the cylinder, move the valve piston no. 22 to ensure the sliding valve no. 24 moves easily and doesn't stick.

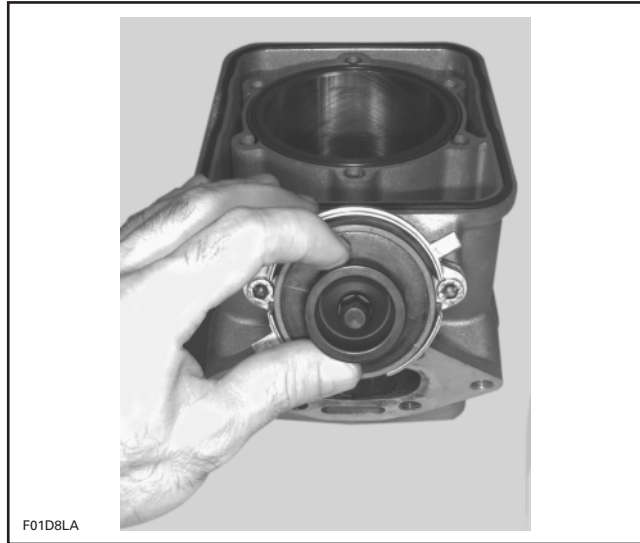

All Engines

3, Piston

At assembly, place the pistons over the connecting rods with the letters "AUS" (over an arrow on the piston dome) facing in direction of the exhaust port.

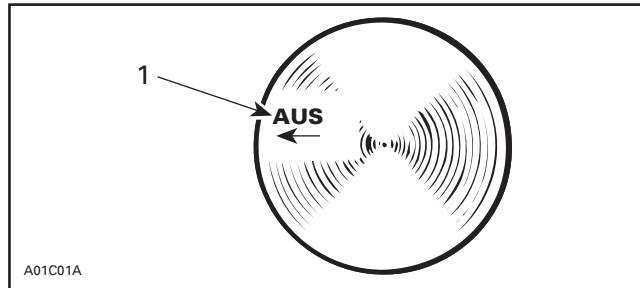

1. Exhaust side

NOTE: On the 787 engine, the exhaust ports are located on the same side as the intake.

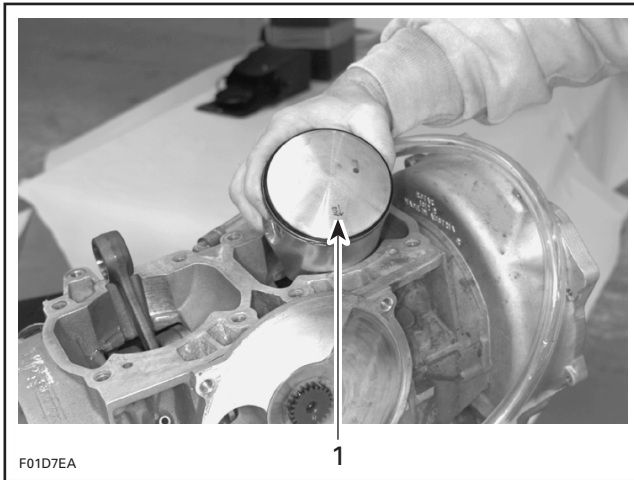

F01D7EA

1. "AUS"

Carefully cover crankcase opening as for disassembly.

4,6, Piston Pin and Roller Bearing

To install roller bearing and piston pin use piston pin puller (P/N 290 877 092), proceed as follows:

- Replacement bearings are held in place by a locating sleeve outside and 2 plastic cage halves inside.
- Push needle bearing together with inner halves out of the locating sleeve into the connecting rod bore.
- Use any suitable 23 mm (.905 in) diameter pusher as a tool. Make sure thrust washers are present each side of needles.

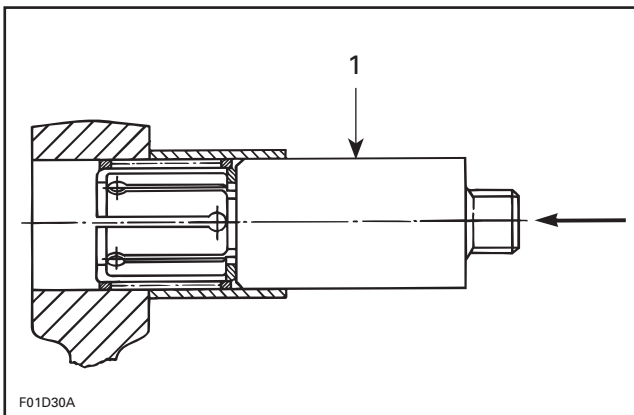

F01D30A

1. Pusher

- Insert piston pin into piston until it comes flush with inward edge of piston hub.
- Warm piston to approximately 50-60°C (122-140°F) and install it over connecting rod.

- Insert extractor spindle into the piston pin, screw on extracting nut.
- Rotate handle to pull piston pin carefully into the piston.

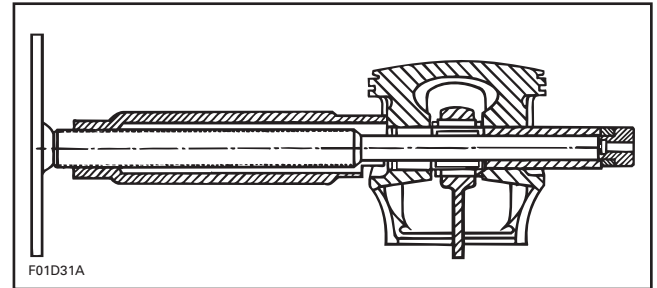

Plastic Mounting Device Method

This is an alternate method when no service tool is available.

Replacement roller bearings are delivered in a convenient plastic mounting device. For installation, proceed as follows:

- Align replacement roller bearing with connecting rod bore.
- Carefully push inner plastic sleeve into connecting rod bore; outer plastic ring will release rollers.

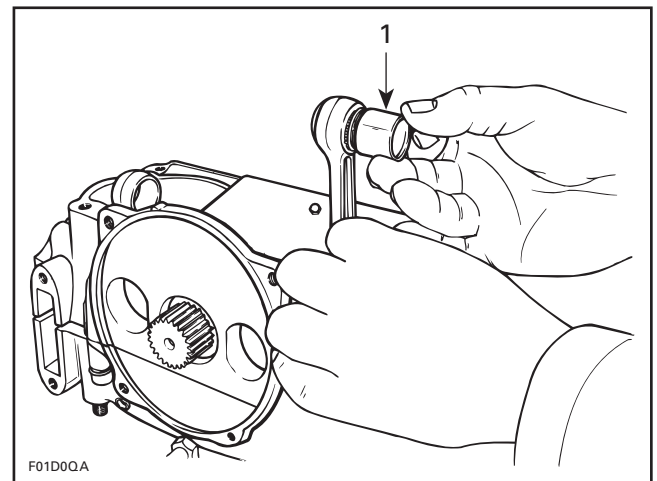

1. Outer ring removal after inner sleeve insertion into bore

- Make sure thrust washers are present each side of rollers.

Section 03 ENGINE

Sub-Section 05 (TOP END)

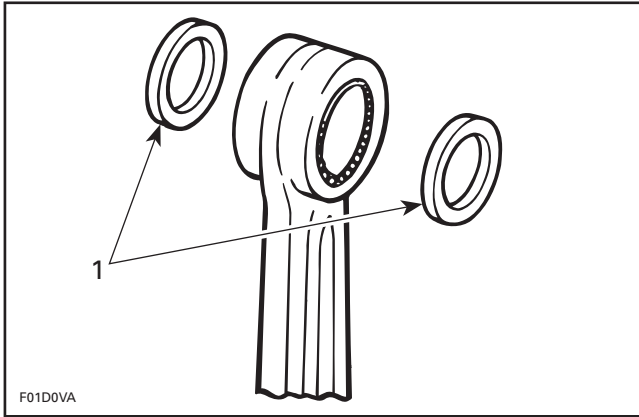

1. Thrust washer each side

- Insert piston pin into piston until it comes flush with inward edge of piston hub.

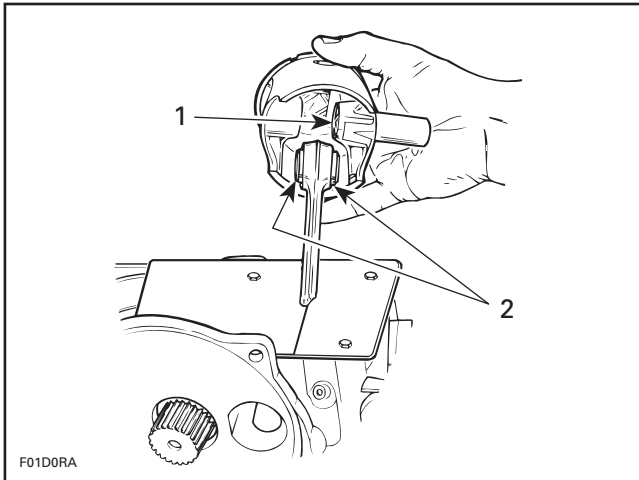

1. Piston pin flush here
2. Thrust washers

- Place piston over connecting rod and align bores, then gently tap piston pin with a fiber hammer to push out inner plastic ring on opposite side. Support piston from opposite side.

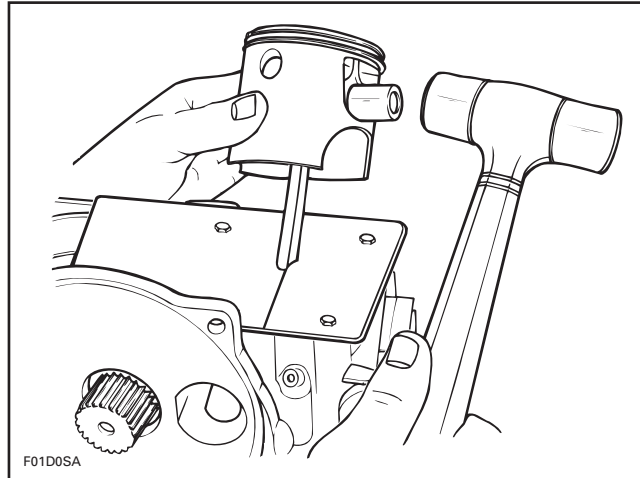

- As necessary, pull halves of inner sleeve with long nose pliers.

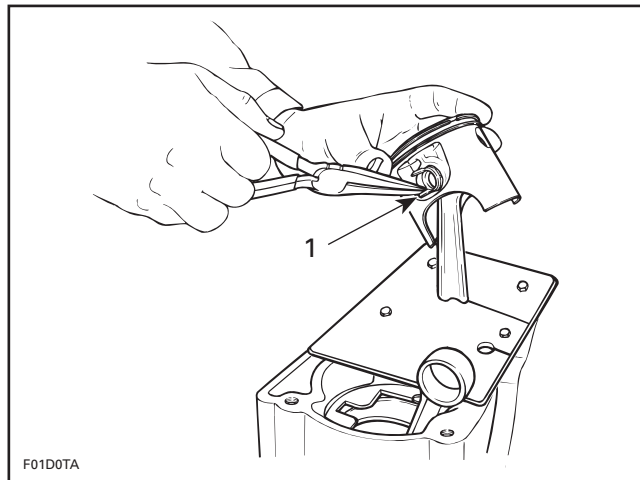

1. Pulling inner sleeve half

5, Circlip

Secure remaining circlip no. 5 taking into consideration the following.

▼ CAUTION

To minimize the stress on the circlips, install them so that their openings are located at 6 o'clock (at bottom). Always use new circlips. At installation, take care not to deform them.

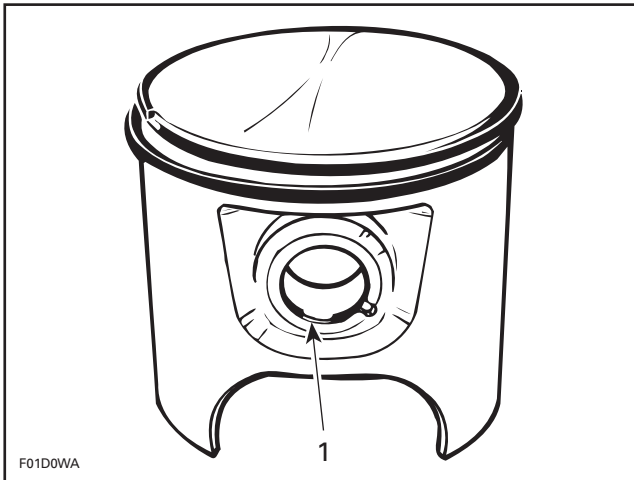

1. Circlip opening at 6 o'clock (at bottom)

◆ WARNING

Always wear safety glasses when installing piston circlips.

To easily insert circlip no. 5 into piston no. 3, use circlip installer P/N 290 877 016.

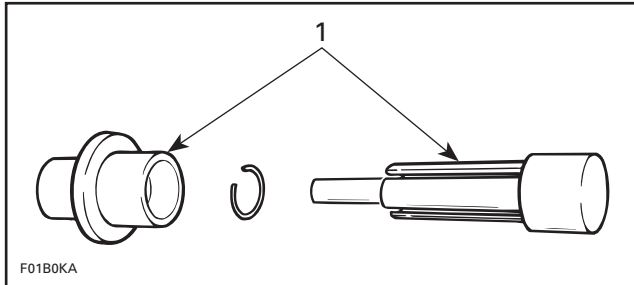

1. Circlip installer

- Remove pusher from tool then insert circlip into its bore.
- Reinstall pusher into tool and push until circlip comes in end of tool.
- Position end of tool against piston pin opening.
- Firmly hold piston against tool and push tool pusher to insert circlip into its groove.

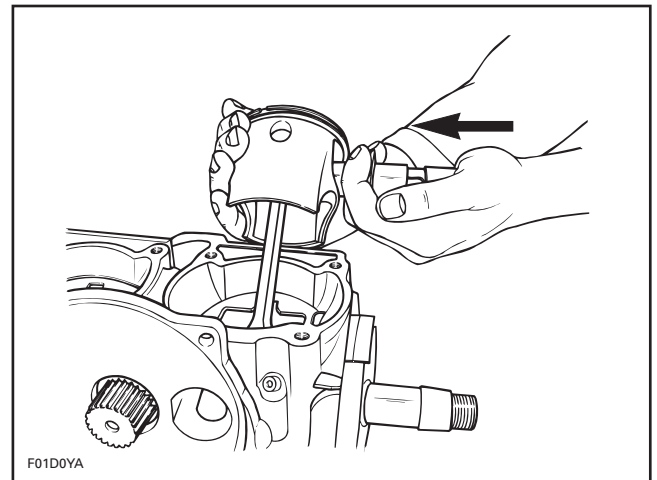

▼ CAUTION

Circlips must not move freely after installation.

9, Cylinder

To easily slide cylinder no. 9 over piston no. 3, install on piston ring compressor P/N 290 876 979.

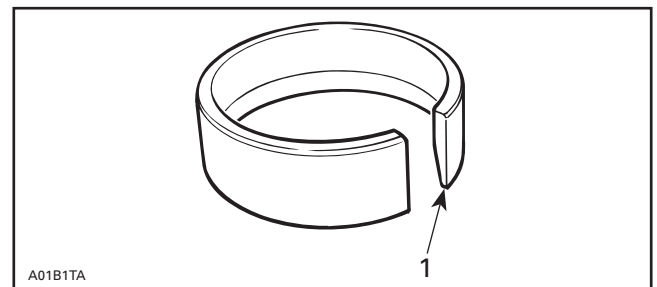

1. Slide this edge

NOTE: Ring compressor will not fit on oversize parts.

Make sure to align ring end gap with piston locating pin. Slide tool over rings.

Section 03 ENGINE

Sub-Section 05 (TOP END)

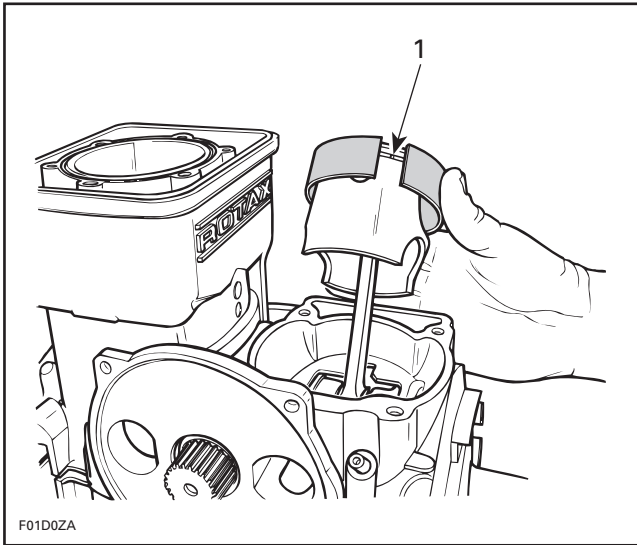

1. Ring end gap aligned with piston locating pin

Slide cylinder no. 9 over piston no. 3.

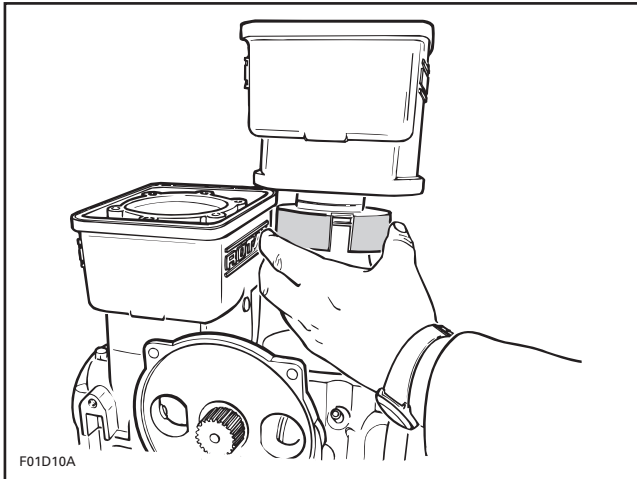

When reassembling cylinders no. 9 to crankcase, it is important to have them properly aligned so that exhaust flanges properly match up with exhaust manifold.

717 Engines

The aligning tool (P/N 290 876 902) or the exhaust manifold can be used to align cylinders.

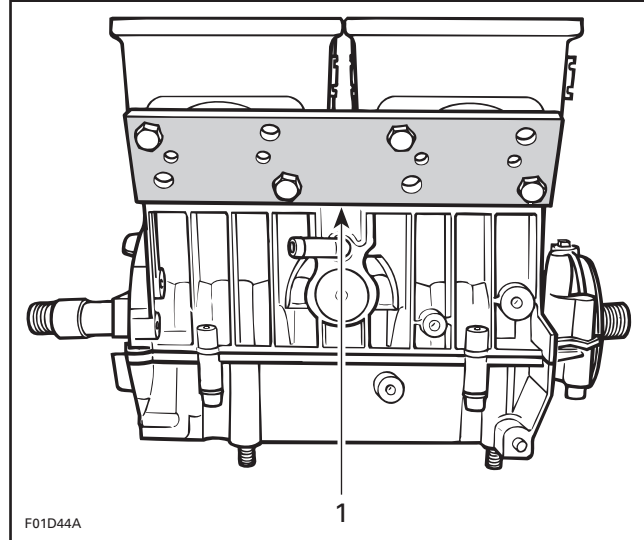

717 ENGINES

1. Exhaust flange aligning tool

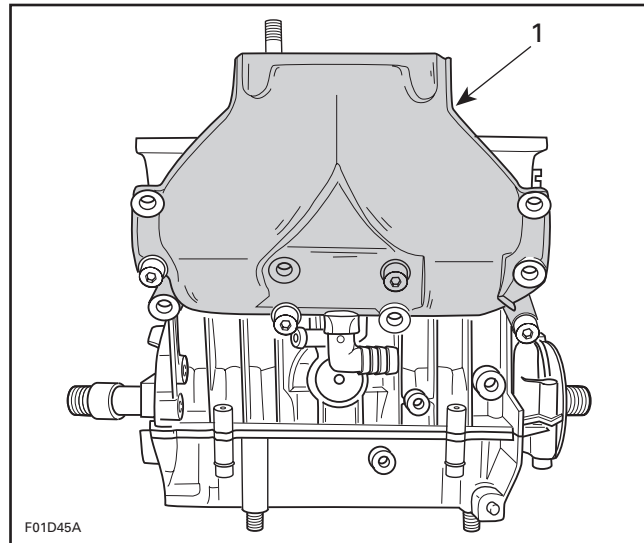

717 ENGINES

1. Aligning cylinders using exhaust manifold

787 Engine

The exhaust manifold is used to align cylinders.

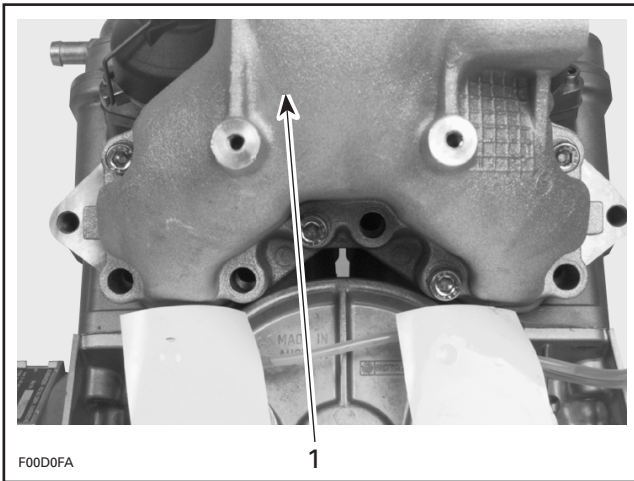

F00D0FA

1. Aligning cylinders using exhaust manifold

17,18, Cylinder Screw

717 Engines

Apply synthetic grease below the screw head.

Apply also Loctite 242 (blue) on screw threads.

Install and torque screws in a criss-cross sequence for each cylinder to 24 N•m (17 lbf•ft). Refer to the following illustration.

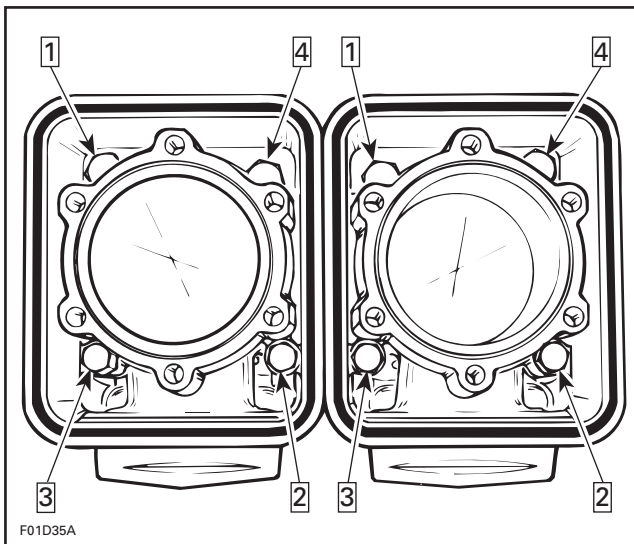

F01D35A

787 Engine

Prior installation, apply synthetic grease below screw head and Loctite 515 on screw threads.

Install M10 x 105 screws on exhaust side and the M10 x 73,5 on opposite side.

Torque screws in a criss-cross sequence for each cylinder to 20 N•m (15 lbf•ft). Repeat the procedure, retightening all cylinder screws to 40 N•m (30 lbf•ft).

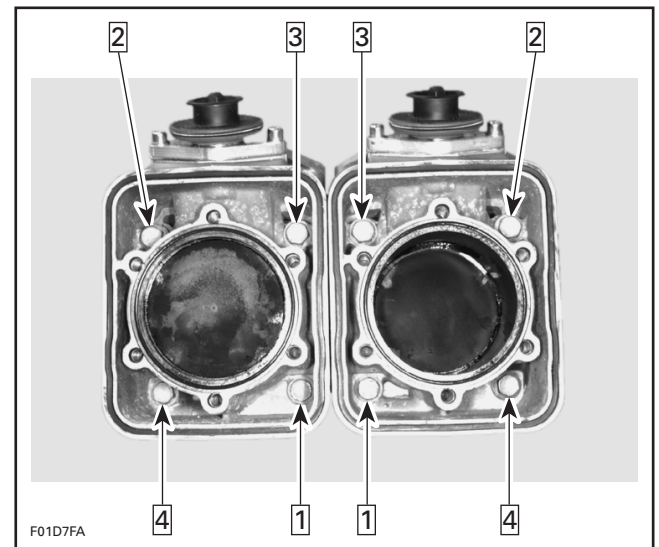

F01D7FA

2, Cylinder Head

Make sure to install O-rings no. 12 around spark plug holes and O-ring no. 31 of cylinder head as shown in the following illustration.

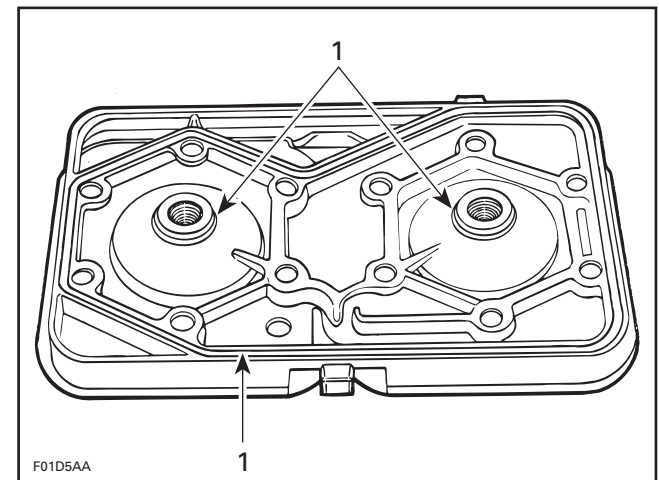

F01D5AA

1. O-rings

Apply Loctite 515 in O-ring groove of cylinder sleeves.

Install cylinder head.

Section 03 ENGINE

Sub-Section 05 (TOP END)

1, Cylinder Head Cover

Install cylinder head cover.

Apply Loctite 242 (blue) below head of screws no. 15.

Apply also synthetic grease on threads of screws no. 15.

Torque cylinder head screws no. 15 to 12 N•m (9 lbf•ft) as per following illustrated sequence. Repeat the procedure, retightening all screws no. 15 to 24 N•m (17 lbf•ft).

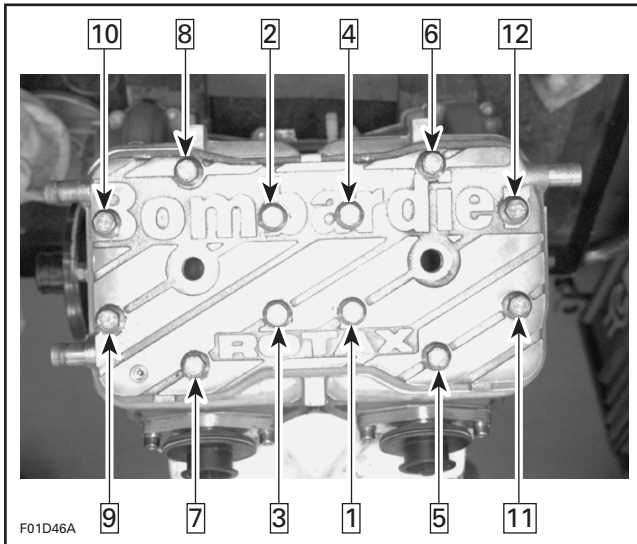

ADJUSTMENT

RAVE Valve

Turn the red plastic knob no. 28 until it is equal to the valve cover.

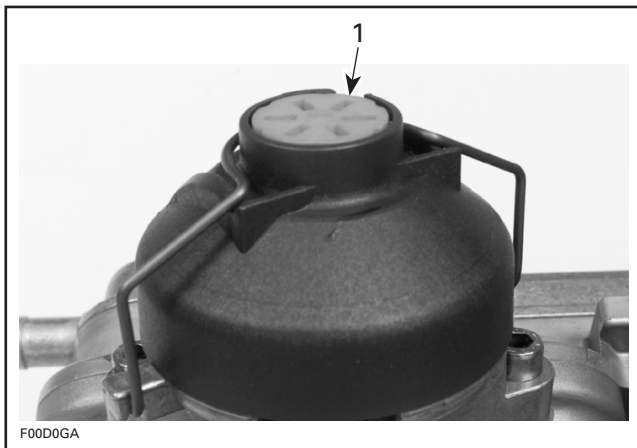

1. Knob equal with the cover

This will ensure the correct preload on the return spring no. 29 in order to open and close the RAVE valve at the proper RPM.

Combustion Chamber Volume Measurement

The combustion chamber volume is the region in the cylinder head above the piston at Top Dead Center. It is measured with the cylinder head installed on the engine.

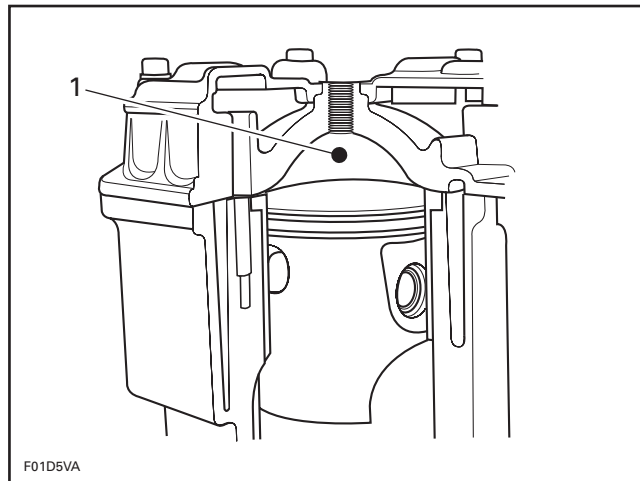

1. Combustion chamber

NOTE: When checking the combustion chamber volume, engine must be cold, piston must be free of carbon deposit and cylinder head must be leveled.

1. Remove both spark plugs and bring one piston to Top Dead Center using a TDC gauge.

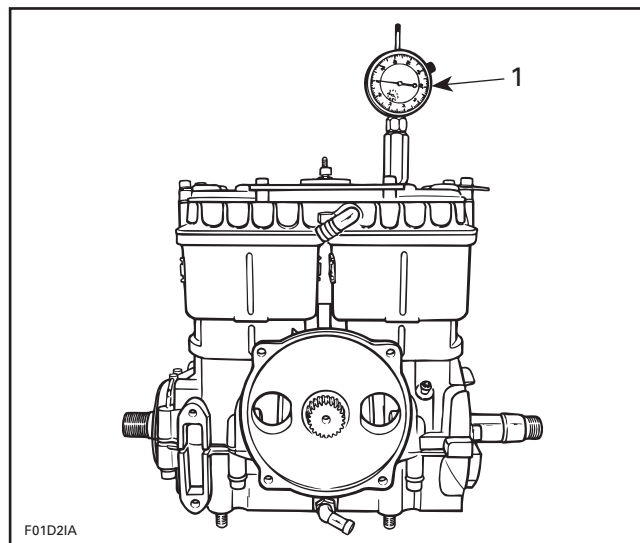

1. Bring piston to TDC

2. Obtain a graduated burette (capacity 0-50 cc) and fill with an equal part (50/50) of gasoline and injection oil.

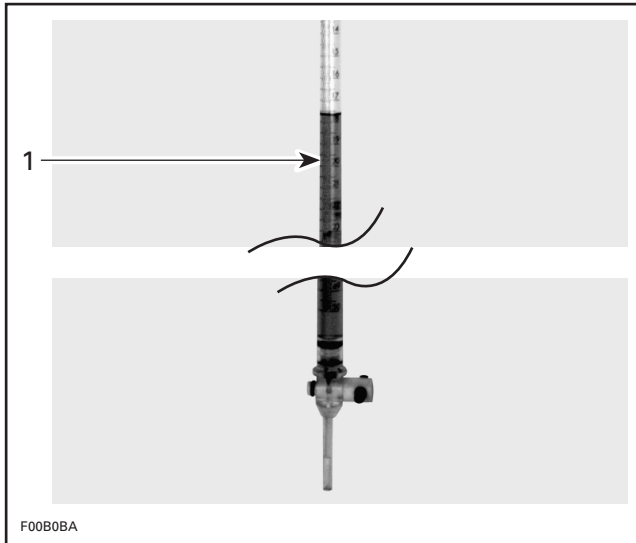

1. Graduated burette (0-50 cc)

3. Open burette valve to fill its tip. Add liquid in burette until level reaches 0 cc.
4. Inject the burette content through the spark plug hole until liquid touches the top spark plug hole.

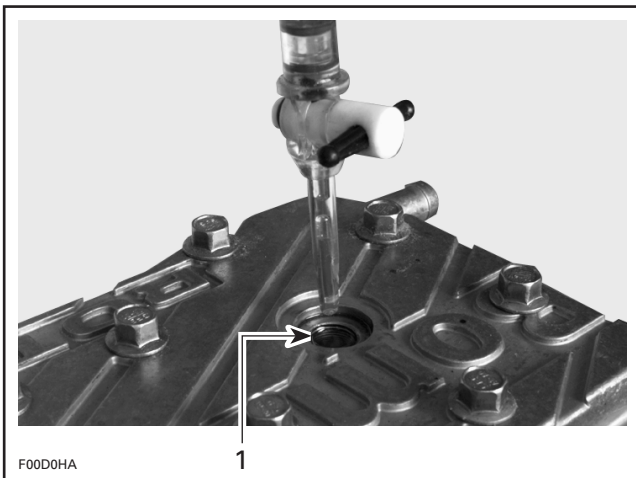

1. Top of spark plug hole

NOTE: The liquid level in cylinder must not drop for a few seconds after filling. If so, there is a leak between piston and cylinder. The recorded volume would be false.

5. Let burette stand upward for about 10 minutes, until liquid level is stabilized.
6. Read the burette scale to obtain the quantity of liquid injected in the combustion chamber.

NOTE: When the combustion chamber is filled to top of spark plug hole, it includes an amount of 2.25 cc for this space (BR7ES or BR8ES have a 19 mm reach head).

7. Repeat the procedure for the other cylinder.

BOTTOM END

717 Engines

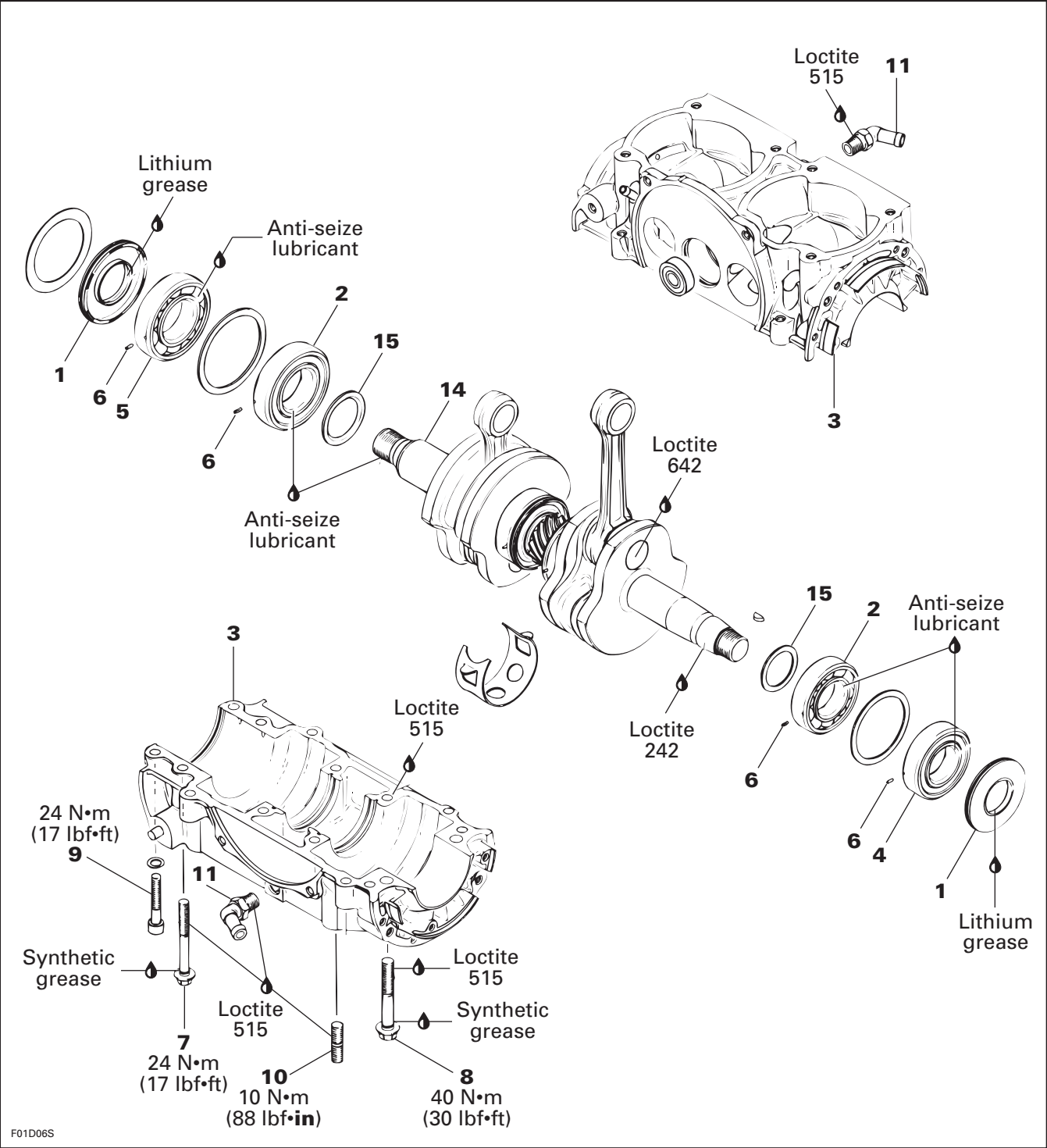

F01D06S

CRANKSHAFT MISALIGNMENT AND DEFLECTION

Since it is an assembled crankshaft it can become misaligned or deflected. Crankshaft can be twisted on center main journal, changing timing of one cylinder in relation with the other.

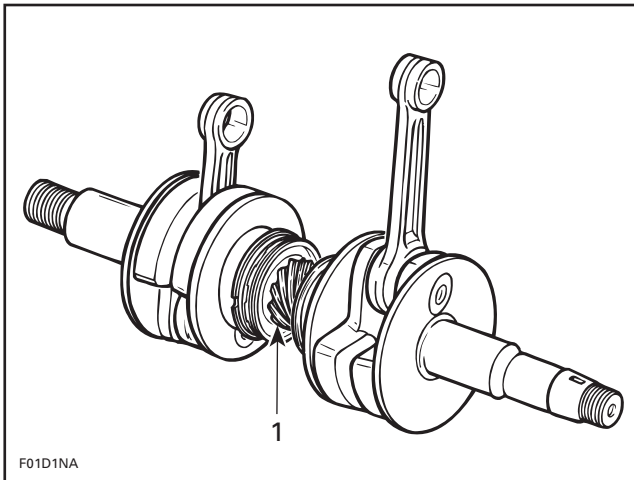

1. Main journal alignment here

Counterweights can also be twisted on connecting rod journal on any or both cylinder(s).

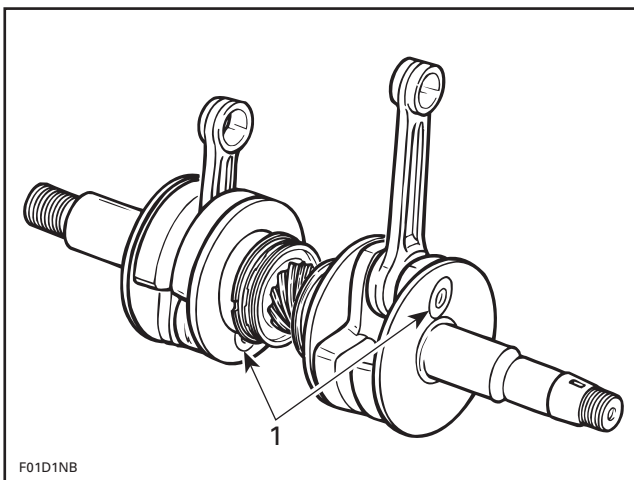

1. Connecting rod journal alignment here

Crankshaft Alignment at Center Main Journal

NOTE: The following checks can be performed with engine in watercraft without overhauling engine.

To accurately check if crankshaft is twisted on center main journal, proceed as follows:

- Remove magneto housing cover.

- Remove flywheel nut (and magneto rotor for the 787 engine). Refer to ENGINE 03-04 for procedures.
- Install Bombardier degree wheel (P/N 295 000 007) on crankshaft end. Hand-tighten nut only.
- Remove both spark plugs.
- Install a TDC gauge in spark plug hole on **MAG side**.
- Bring **MAG** piston at Top Dead Center.
- As a needle pointer, secure a wire with a cover screw and a washer.
- Rotate degree wheel (NOT crankshaft) so that needle pointer reads 360°.

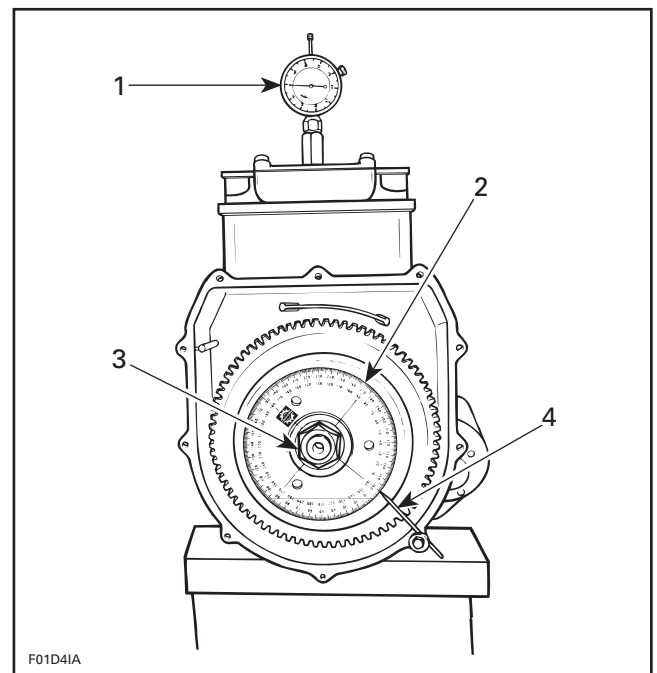

1. TDC gauge
2. Degree wheel
3. Hand tighten nut
4. Needle pointer

- Remove TDC gauge and install on **PTO side**.
- Bring **PTO** piston at Top Dead Center.

Interval between cylinders must be exactly 180° therefore, needle pointer must indicate 180° on degree wheel (360° - 180° = 180°).

Any other reading indicates a misaligned crankshaft.

Section 03 ENGINE

Sub-Section 06 (BOTTOM END)

Crankshaft Alignment at Connecting Rod Journal

Such misalignment may cause a crankshaft hard to be manually turned. Verification can be done by measuring deflection each end of crankshaft. Refer to Inspection paragraph.

If deflection is found greater than specified tolerance, this indicates worn bearing(s), bent and/or disaligned crankshaft.

DISASSEMBLY

Engine has to be removed from watercraft to open bottom end. Refer to ENGINE 03-03.

1, Seal

If a crankshaft end seal has to be replaced, bottom end must be opened (except for the MAG side seal on the 787 engine, which is mounted on the magneto housing).

3, Crankcase

Remove the following parts:

- engine support (except for the 787 engine)
- PTO flywheel, refer to PROPULSION SYSTEM 08-03

NOTE: PTO flywheel must be removed prior removing MAG flywheel.

- magneto flywheel, refer to ENGINE 03-04
- starter
- magneto housing
- rotary valve cover and valve
- crankcase retaining screws

Insert screwdrivers between crankcase lugs and pry to separate halves being careful not to damage precision machined surfaces.

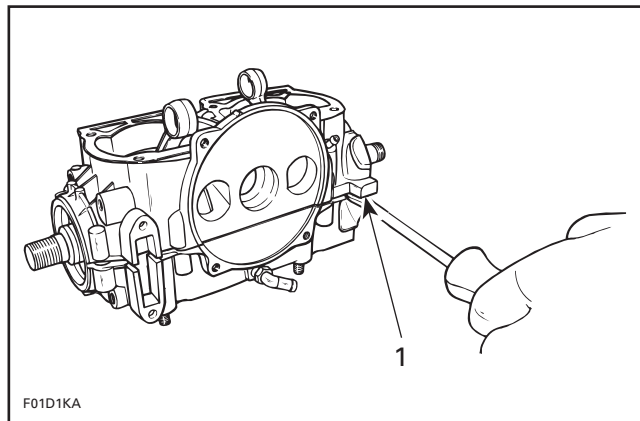

1. Separate halves by prying at provided lugs

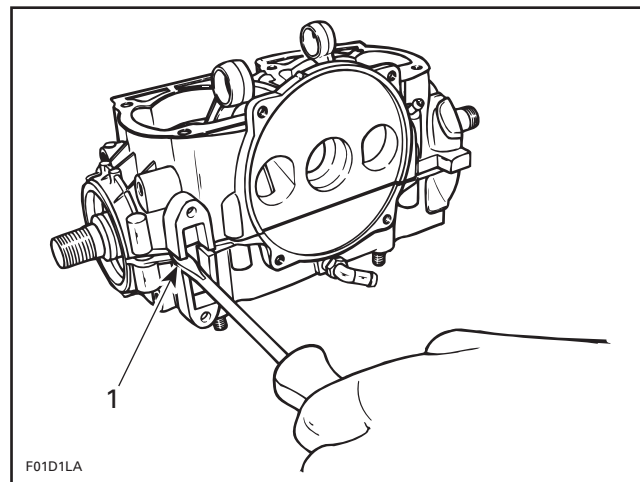

1. Separate halves by prying at provided lugs

Remove crankshaft and counterbalance shaft (787 engine).

1,2,4,5, Seal and Bearing

NOTE: Do not needlessly remove crankshaft bearings.

Remove end seal(s).

To remove end bearings from crankshaft, use protective cap (P/N 290 876 557) and puller (P/N 290 876 298).

717 Engines

On PTO side, use ring (P/N 290 977 490) with ring halves (P/N 290 977 475).

On MAG side, use distance ring (P/N 290 876 569), ring (P/N 290 977 490) with ring halves (P/N 290 276 025).

NOTE: To facilitate ring or distance ring installation lubricate their inside diameters.

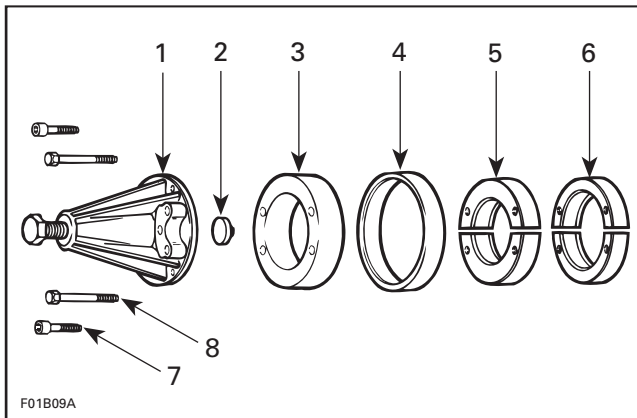

1. Puller (P/N 290 876 298)
2. Protective cap (P/N 290 876 557)
3. Distance ring, MAG side (P/N 290 876 569)
4. Ring (both side) (P/N 290 977 490)
5. MAG side ring halves (P/N 290 276 025)
6. PTO side ring halves (P/N 290 977 475)
7. Screw M8 x 40 (P/N 290 840 681)
8. Screw M8 x 70 (P/N 290 841 201)

787 Engine

For MAG and PTO sides, use distance ring (P/N 290 876 569), ring (P/N 290 977 490) and ring halves (P/N 290 977 475).

NOTE: The outer PTO bearing and crankshaft gear can be removed in one step using another puller. See **Crankshaft Gear no. 13**.

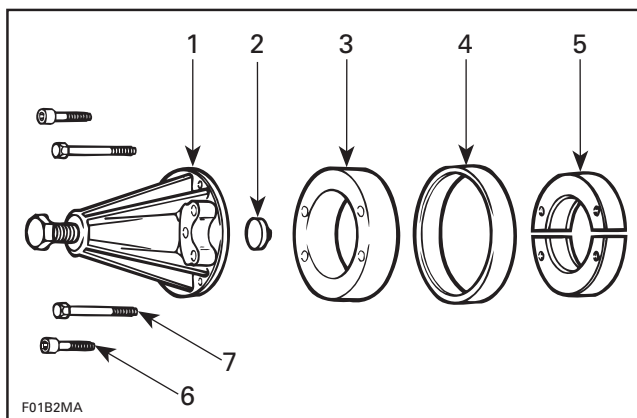

1. Puller (P/N 290 876 298)
2. Protective cap (P/N 290 876 557)
3. Distance ring (P/N 290 876 569)
4. Ring (P/N 290 977 490)
5. Ring halves (P/N 290 977 475)
6. Screw M8 x 40 (P/N 290 840 681)
7. Screw M8 x 70 (P/N 290 841 201)

NOTE: To facilitate ring or distance ring installation lubricate their inside diameters.

All Engines

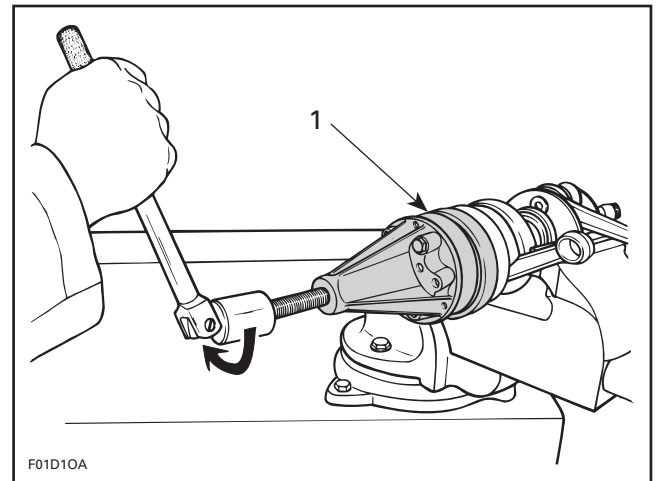

TYPICAL

1. Removing crankshaft bearing

Or, use a bearing extractor such as Proto no. 4332 and a press to remove two bearings at a time (except on PTO side for the 787 engine).

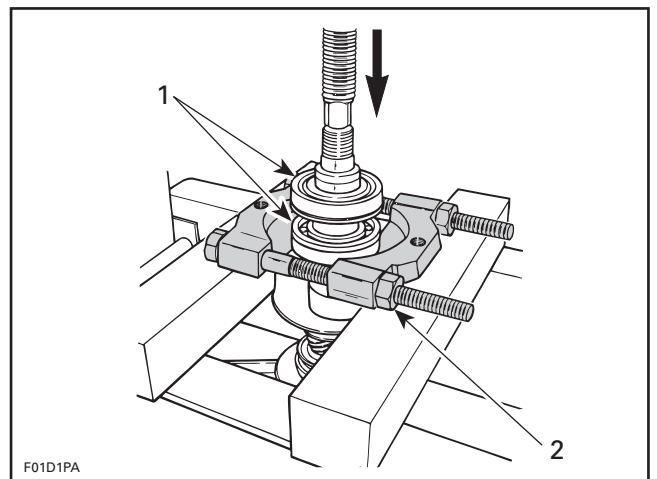

1. Press bearings out
2. Bearing extractor

787 Engine

13, Crankshaft Gear

The crankshaft gear and bearing no. 5 can be removed in one step using the following puller:

Section 03 ENGINE

Sub-Section 06 (BOTTOM END)

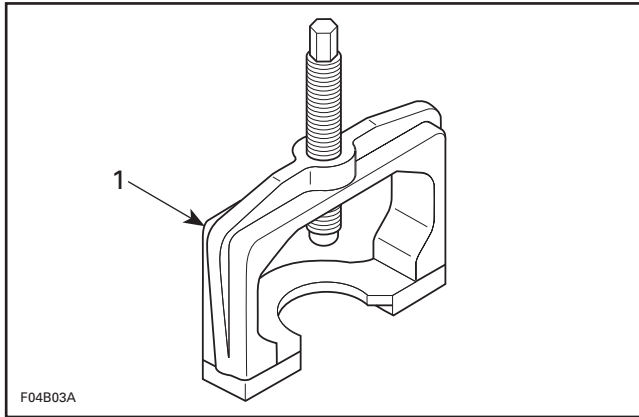

1. Puller (P/N 290 877 665)

Install the puller as per following illustration.

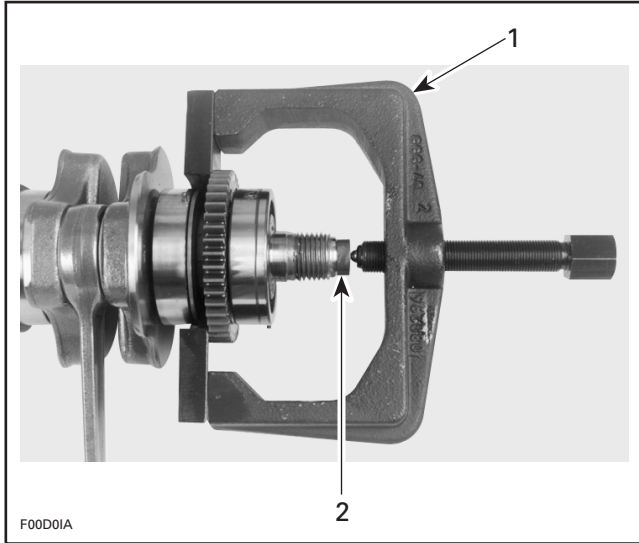

1. Puller
2. Protective cap

Secure puller in a vise and remove gear and bearing.

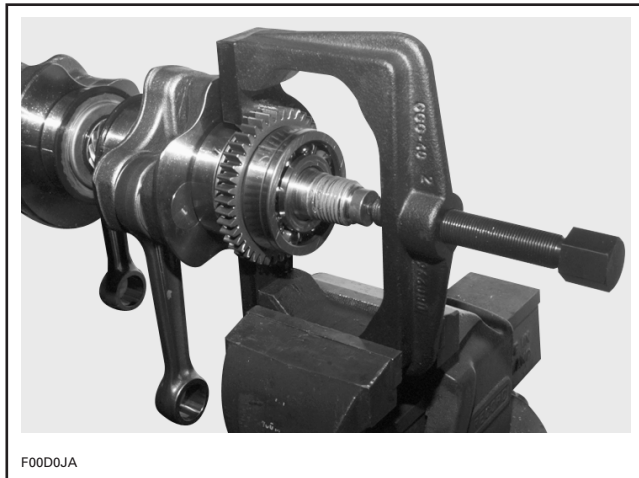

NOTE: If the inner PTO bearing needs to be replaced, remove the Woodruff key on the crankshaft.

16, Counterbalance Shaft

Bearings no. 12 can be removed by using the following tools:

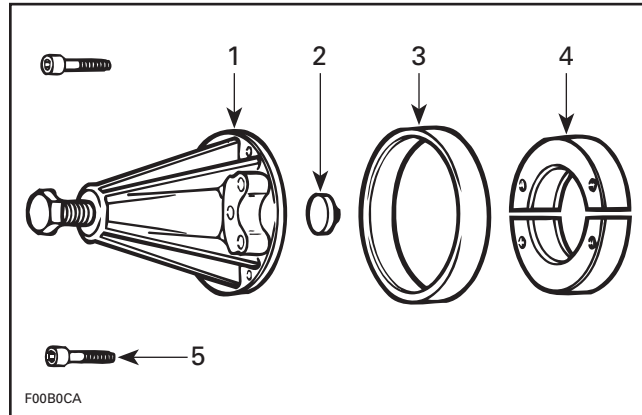

1. Puller (P/N 290 876 298)
2. Protective cap (P/N 290 876 557)
3. Ring (P/N 290 977 480)
4. Ring halves (P/N 290 876 330)
5. Screw M8 x 40 (P/N 290 840 681)

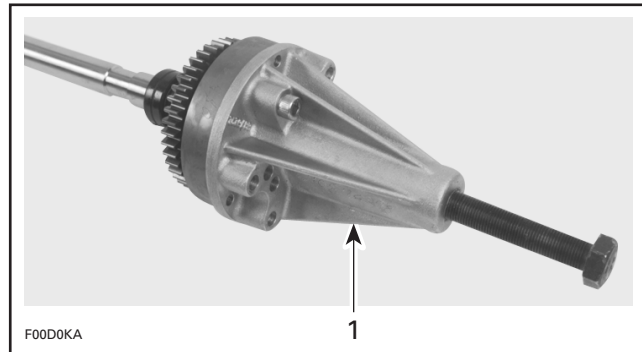

1. Tool installed

To remove gear no. 18, first trace an index mark on the gear and counterbalance shaft.

NOTE: There is no Woodruff key to position the gear on the counterbalance shaft. An index mark must be traced to ease assembly procedure.

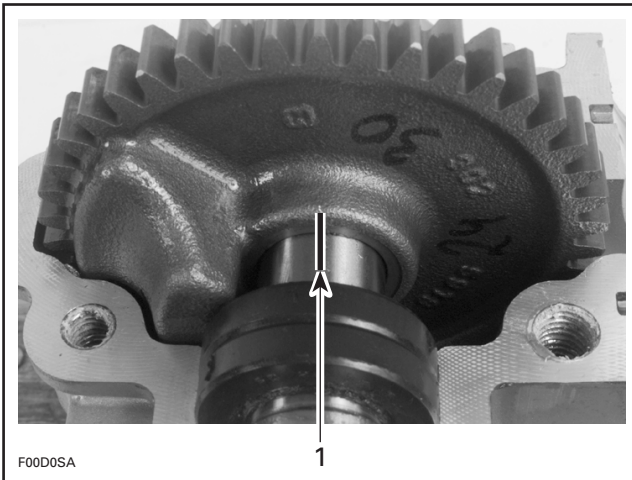

1. Index mark

Use a press to remove the gear no. 18 from the counterbalance shaft.

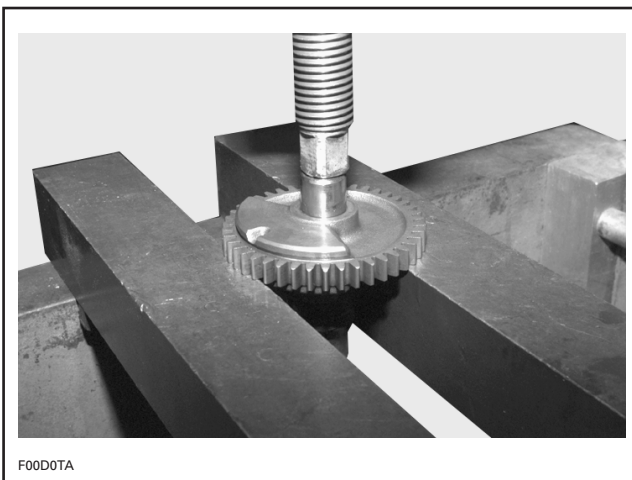

F00D0TA

CLEANING

Discard all oil seals, gaskets, O-rings and sealing rings.

Clean oil passages and make sure they are not clogged.

Clean all metal components in a solvent.

Remove old Loctite from crankcase mating surfaces with gasket remover (P/N 295 000 110).

▼ CAUTION

Be careful not to spray cleaner on the painted surface of the engine. Never use a sharp object to scrape away old sealant as score marks incurred are detrimental to crankcase sealing.

INSPECTION

Visually inspect parts for corrosion damage.

Inspect plane surfaces for warpage. Small deformation can be corrected by grinding surface with a fine sand paper. Install sand paper on a surface plate and rub part against oiled sand paper.

Inspect crankshaft bearings. Check for scoring, pitting, chipping or other evidence of wear. Make sure plastic cage is not melted. Rotate and make sure they turn smoothly.

If crankshaft and/or components are found defective, it must be repaired by a specialized shop or replaced.

The inspection of engine bottom end should include the following measurements:

MEASUREMENT	NEW PARTS		WEAR LIMIT
	(min.)	(max.)	
Connecting rod big end axial play	0.390 mm (.015 in)	.737 mm (.029 in)	1.2 mm (.047 in)

MEASUREMENT	MAG SIDE	PTO SIDE
Crankshaft deflection (max.)	0.050 mm (.002 in)	0.030 mm (.001 in)

Connecting Rod Straightness

Align a steel ruler on edge of small end connecting rod bore. Check if ruler is perfectly aligned with edge of big end.

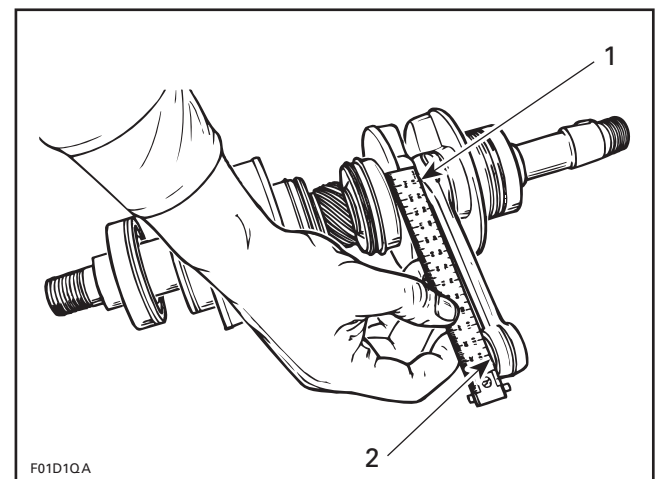

F01D1QA

1. Ruler must be aligned with edge of connecting rod here
2. Align ruler here

Section 03 ENGINE

Sub-Section 06 (BOTTOM END)

Crankshaft Deflection

Crankshaft deflection is measured each end with a dial indicator.

First, check deflection with crankshaft in crankcase. If deflection exceeds the specified tolerance, it can be either ball bearings wear, bent or twisted crankshaft at connecting rod journal.

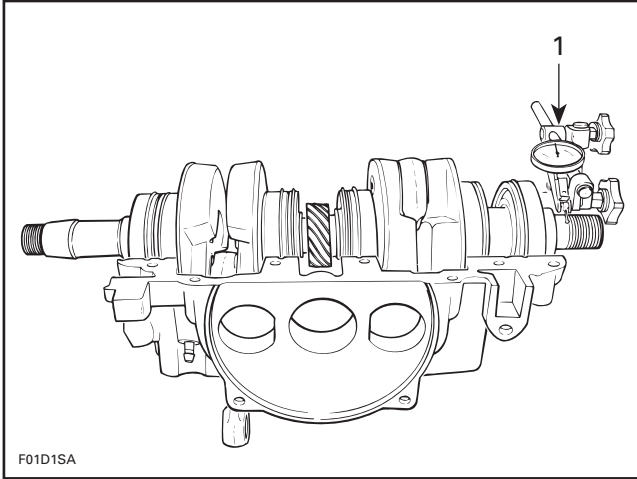

1. Measuring PTO side deflection in crankcase

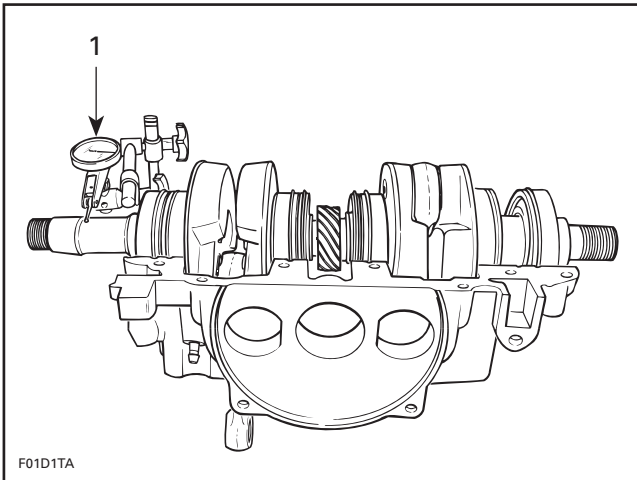

1. Measuring MAG side deflection in crankcase

Remove crankshaft bearings and check deflection again on V-shaped blocks as illustrated.

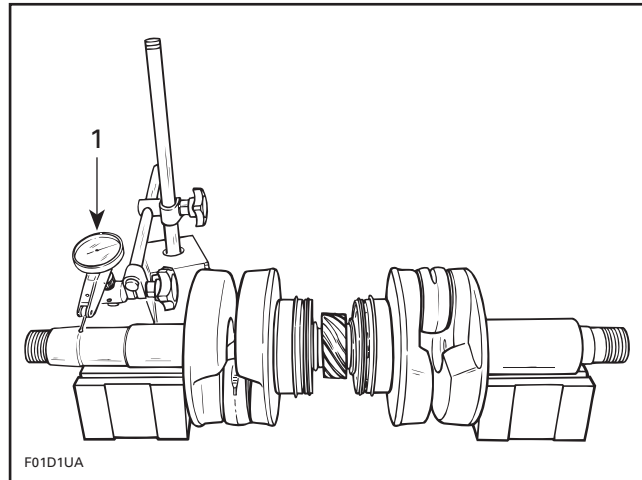

1. Measuring MAG side deflection on V-shaped blocks

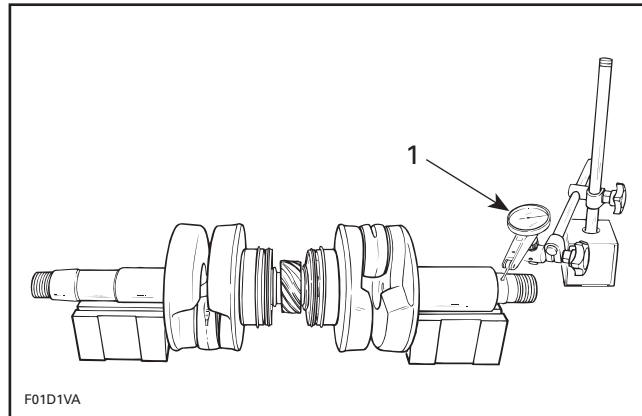

1. Measuring PTO side deflection on V-shaped blocks

NOTE: Crankshaft deflection can not be correctly measured between centers of a lathe.

Connecting Rod Big End Axial Play

Using a feeler gauge, measure distance between thrust washer and crankshaft counterweight.

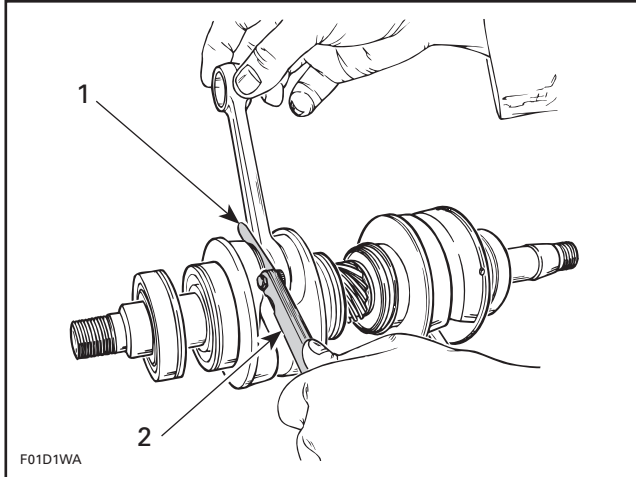

1. Measuring big end axial play
2. Feeler gauge

ASSEMBLY

Assembly is essentially the reverse of disassembly procedures. However pay particular attention to the following.

2,4,5,14, Bearing and Crankshaft

Apply Loctite 767 anti-seize on part of crankshaft where bearing fits.

Prior to installation, place bearings into a container filled with oil, previously heated to 75°C (167°F). This will expand bearing and ease installation.

To properly position the outer PTO side bearing no. 5 on 717 engines or the outer MAG side bearing no. 4 on the 787 engine, a distance gauge must be temporarily installed against the inner bearing. Slide the outer bearing until stopped by the distance gauge, then remove it.

ENGINE	DISTANCE GAUGE
717	P/N 290 876 827
787	P/N 290 876 828

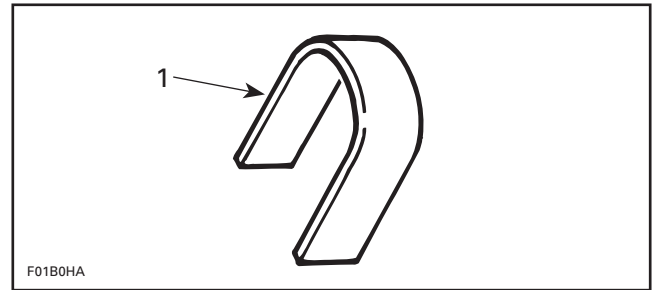

1. Distance gauge

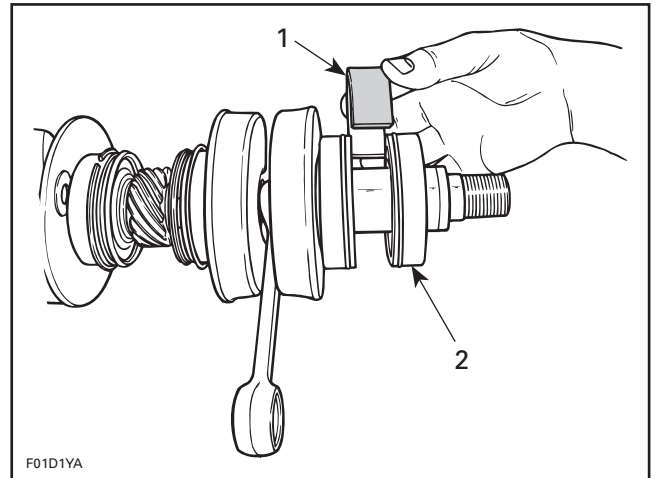

TYPICAL

1. Distance gauge
2. Outer bearing

15, Distance Ring

When installing the distance ring, make sure to position it with its chamfer toward the counterweight of the crankshaft.

787 Engine

13, Crankshaft Gear

Position the long flange of the gear toward the counterweight of the crankshaft. Also, make sure to align the gear keyway with the Woodruff key on the crankshaft.

Section 03 ENGINE

Sub-Section 06 (BOTTOM END)

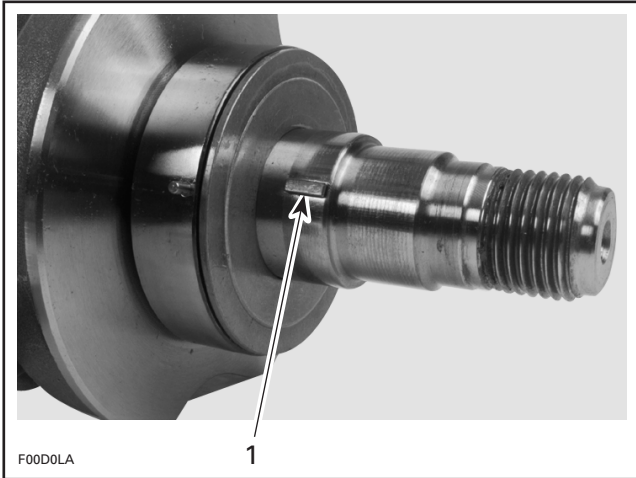

1. Woodruff key on the crankshaft

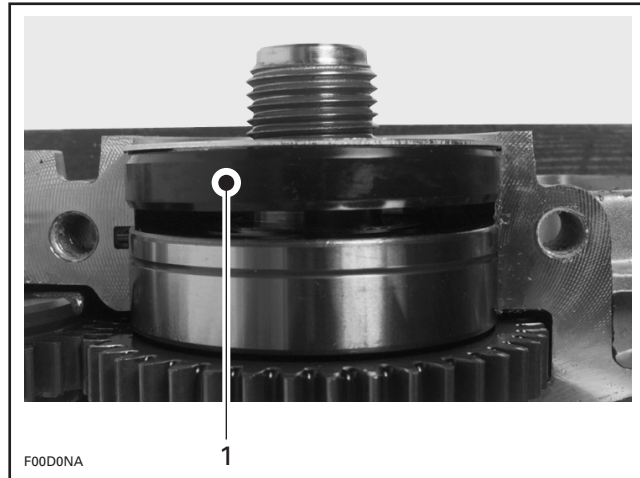

1. Seal against the retaining shim

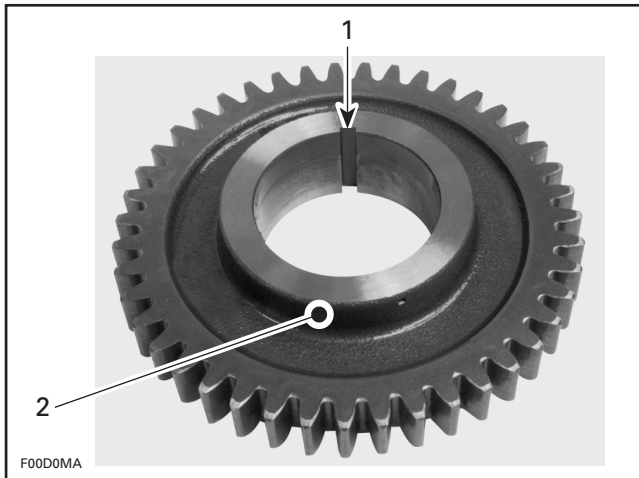

1. Keyway
2. Long flange toward the crankshaft counterweight

1, Seal

At seal assembly, apply a light coat of lithium grease on seal lips.

787 Engine

Position PTO seal no. 1 against the retaining shim; the gap between the seal and bearing will ensure proper lubrication of the bearing.

All Engines

6, Drive Pin

Make sure drive pins of bearings are properly installed in crankcase recesses at assembly.

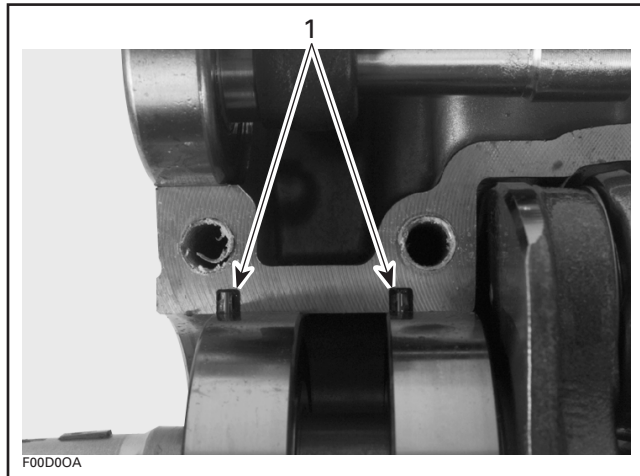

1. Drive pin

787 Engine

16,18, Counterbalance Shaft and Gear

Press gear no. 18 onto counterbalance shaft taking care to align both marks previously traced.

▼ CAUTION

Counterbalance shaft must be properly assembled, otherwise engine will vibrate and premature wear will occur.

Proceed as follows to check if the gear no. 18 is properly positioned on the counterbalance shaft:

- Temporarily install the counterbalance shaft in the crankcase.
- Rotate the counterbalance shaft to align the notch of the gear with the crankcase.

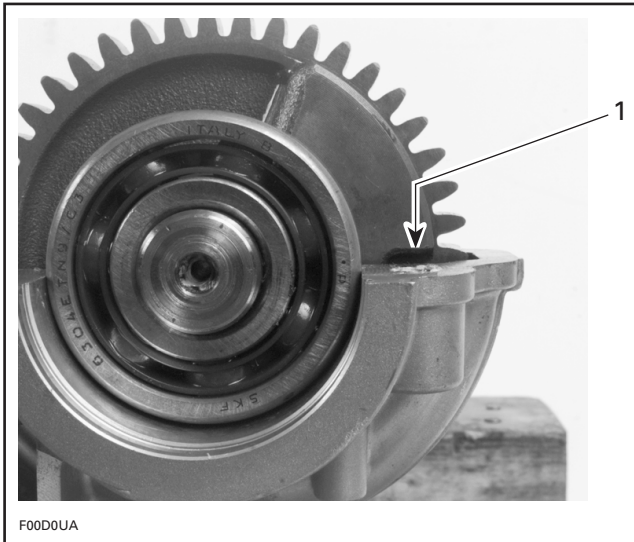

1. Gear notch aligned with the crankcase

- The notch of the counterweight on the opposite end of the counterbalance shaft must also be aligned with the crankcase.

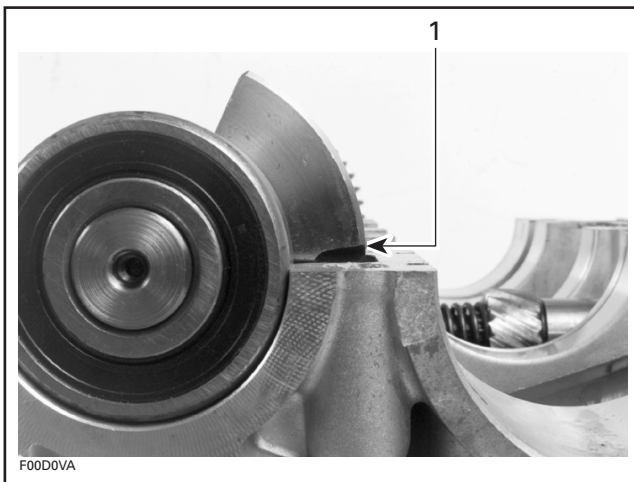

1. Counterweight notch aligned with the crankcase

If notches are not aligned with the crankcase, remove the gear and repeat the procedure until the notches are properly aligned.

12,16, Bearing and Counterbalance Shaft

Prior to installation, place bearings into a container filled with oil, previously heated to 75°C (167°F). This will expand bearings and ease their installation.

14,16, Crankshaft and Counterbalance Shaft

Install crankshaft first in crankcase.

After crankshaft installation, install counterbalance shaft. Make sure to properly index crankshaft and counterbalance shaft by aligning marks of gears.

▼ CAUTION

Marks on the crankshaft and counterbalance shaft must be aligned, otherwise engine will vibrate and premature wear will occur.

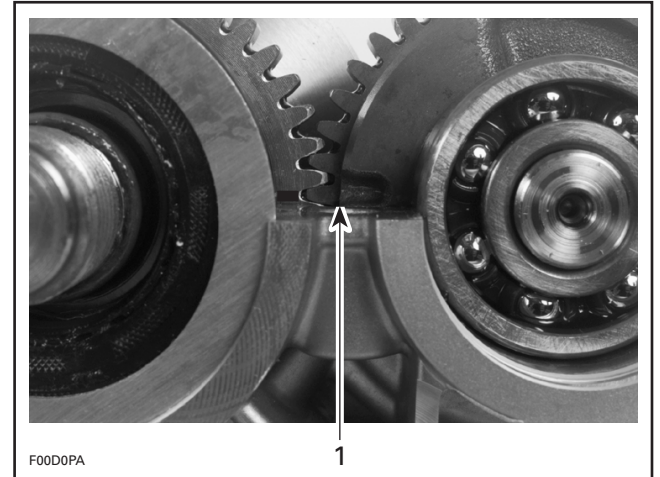

1. Marks must be aligned

Turn by hand the crankshaft and counterbalance shaft. Make sure they do not interfere with the crankcase.

3, Crankcase

Crankcase halves are factory matched and therefore, are not interchangeable or available as single halves.

Prior to joining crankcase halves, apply a light coat of Loctite 515 on mating surfaces. Do not apply in excess as it will spread out inside crankcase.

Section 03 ENGINE

Sub-Section 06 (BOTTOM END)

NOTE: On aluminum material it is recommended to use Loctite Primer N to reduce curing time and increase gap filling capability. Refer to manufacturer's instructions.

▼ CAUTION

Rotary valve shaft must be installed in crankcase before closing halves. Before joining crankcase halves, make sure that crankshaft gear is well engaged with rotary valve shaft gear.

Position crankcase halves together and hand-tighten screws.

▼ CAUTION

Temporarily install armature plate to align crankcase halves with each other (except the 787 engine).

11, Fitting

If inlet and outlet oil fittings of rotary valve shaft have been removed from crankcase, reinstall them with their ends pointing toward ignition housing. Apply Loctite 515 on threads of fittings.

787 Engine

17, Bearing Cover

Install the bearing cover with its hollow side toward the bearing.

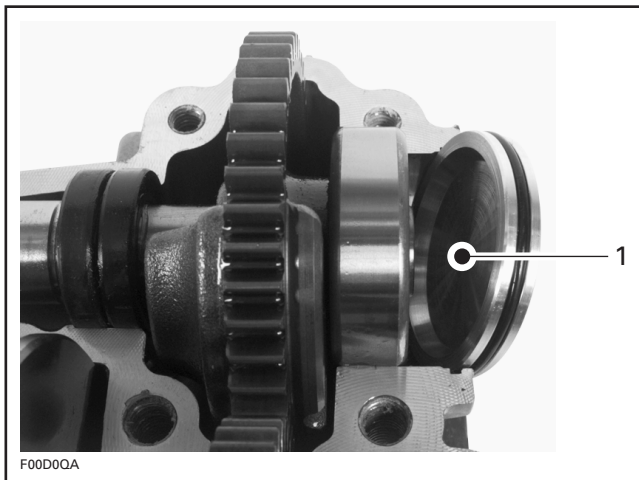

1. Hollow side facing bearing

717 Engines

7,8,9, Crankcase Screw

Apply Loctite 515 on screw threads and synthetic grease below head screws.

Torque crankcase screws to 24 N•m (17 lbf•ft) as per following illustrated sequence.

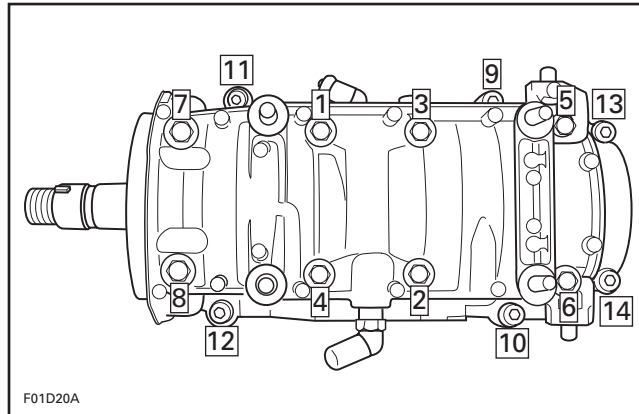

F01D20A

8, Crankcase Screw

Torque 2 M10 crankcase screws to 40 N•m (30 lbf•ft).

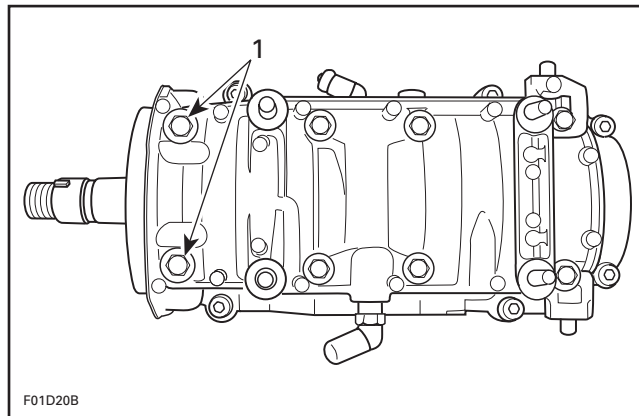

F01D20B

1. Torque to 40 N•m (30 lbf•ft)

10, Stud

At assembly in crankcase, apply Loctite 515 on stud threads. Torque to 10 N•m (88 lbf•in).

787 Engine

7,8, Crankcase Screw

Apply Loctite 515 on screw threads and synthetic grease below head screws.

Torque crankcase screws to 12 N•m (9 lbf•ft) as per following sequence. Repeat procedure, re-tightening all screws to 24 N•m (17 lbf•ft).

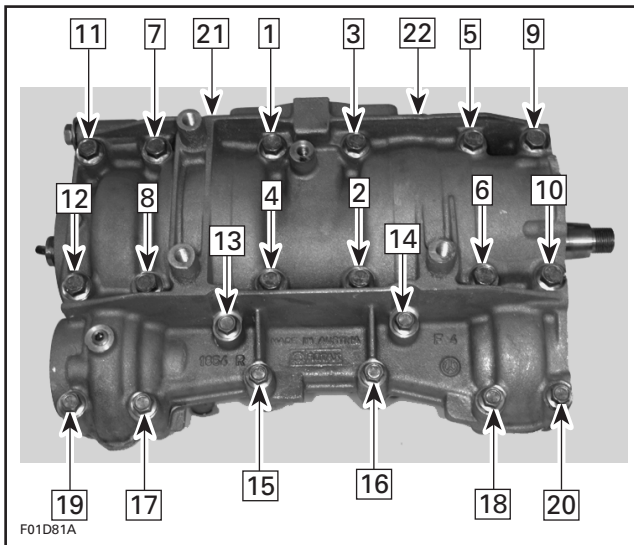

As a final step, torque only M10 screws **no. 8** of crankcase to 40 N•m (30 lbf•ft) as per following sequence.

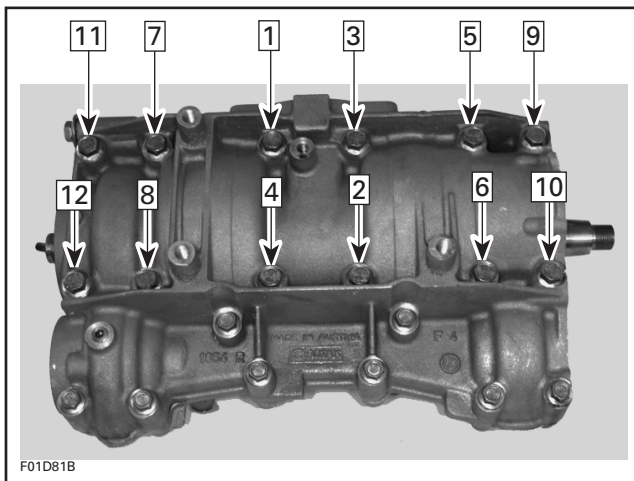

Final Assembly

For rotary valve timing and assembly procedures, refer to ENGINE 03-07.

717 Engines

ONE PIECE ENGINE SUPPORT

If engine support is installed on crankcase before magneto housing, electric starter must be installed before engine support.

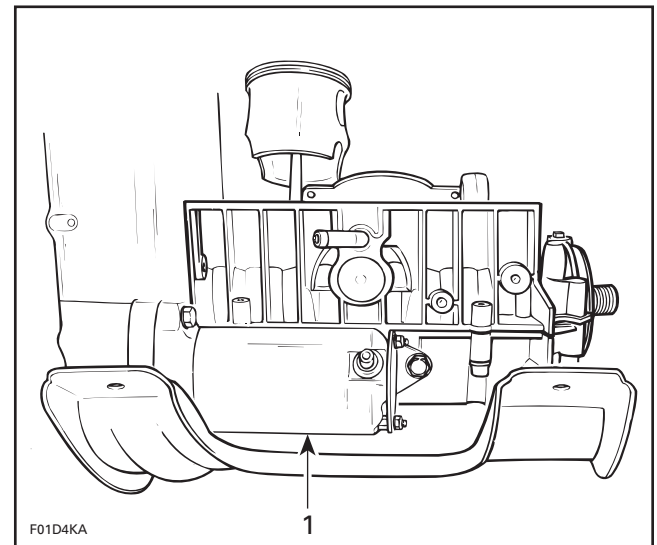

1. Install starter before engine support

787 Engine

When engine assembly is completed, add 30 mL (1oz) of motor oil SAE 30 to the counterbalance shaft gear through the crankcase filler plug.

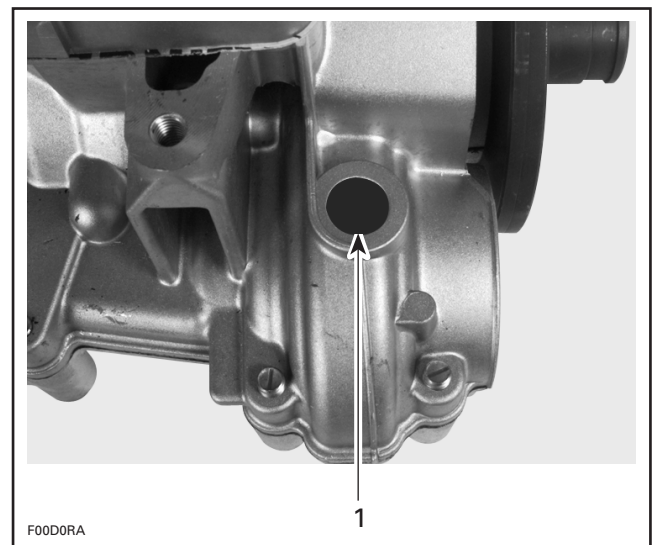

1. Add oil here

Section 03 ENGINE

Sub-Section 07 (ROTARY VALVE)

GENERAL

The following verification procedures such as clearance of rotary valve cover or rotary valve shaft gear backlash can be performed without removing engine from watercraft.

However engine must be removed from watercraft to work on rotary valve shaft/components. Refer to ENGINE 03-03 for engine removal procedure.

Bottom end must be opened to remove rotary valve shaft. Refer to ENGINE 03-06.

INSPECTION ON WATERCRAFT

Remove carburetor(s). Refer to FUEL SYSTEM 05-04.

NOTE: On the 717D engine (SP model), rotary valve cover and carburetor are removed as an assembly.

1, Rotary Valve Cover

Unscrew 4 screws **no. 2** and withdraw rotary valve cover and valve **no. 13**.

Rotary Valve/Cover Clearance

The clearance between the rotary valve and the cover must be 0.30 ± 0.05 mm ($.012 \pm .002$ in).

NOTE: If the clearance is below 0.25 mm (.010 in) this could create an overheating situation and if the clearance is over 0.35 mm (.014 in) this could create a hard starting situation.

There is two methods to verify rotary valve /cover clearance. One with a 45° feeler gauge, the other one with a solder.

45° FEELER GAUGE METHOD

Remove O-ring from rotary valve cover.

Remove intake manifold from rotary valve cover (except 787 engine).

Reinstall cover in place **WITHOUT** its O-ring and torque screws to 20 N•m (15 lbf•ft).

Feeler gauge blade from 0.25 mm (.010 in) to 0.35 mm (.014 in) thickness should fit between rotary valve and cover.

Insert feeler gauge blade through cover inlet ports to verify clearance. At least verify clearance at two different places in each port.

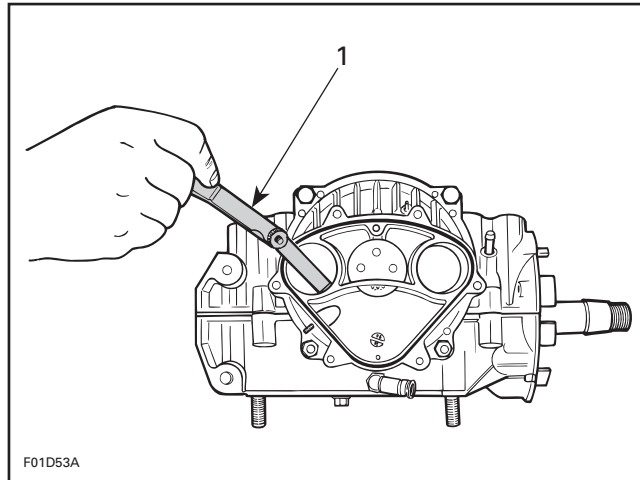

1. 45° feeler gauge

If rotary valve cover clearance is out of specification, machine rotary valve cover seating surface or replace the cover.

SOLDER METHOD

Remove O-ring from rotary valve cover.

Use the following type of solder:

- rosin core
- diameter: 0.8 mm (.032 in)
- electronic application (available at electronic stores)

Install two solder pieces of 13 mm (1/2 in) long directly on rotary valve, one above and one below rotary valve gear. Apply grease to hold solder in position.

Reinstall cover in place **WITHOUT** its O-ring and torque screws to 20 N•m (15 lbf•ft).

Remove cover then clean and measure compressed solder thickness, it must be within the specified tolerance 0.30 ± 0.05 mm ($.012 \pm .002$ in).

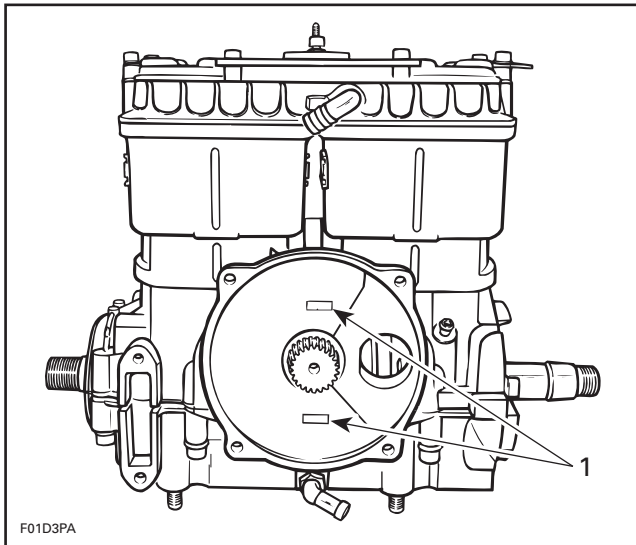

TYPICAL

1. Solder

If rotary valve cover clearance is out of specification, machine rotary valve cover seating surface or replace the cover.

MACHINING INFORMATION

The amount of material over tolerance must be removed from the rotary valve cover seating surface.

Also cut the O-ring groove the same amount to keep the 1.0 ± 0.03 mm (.039 \pm .001 in) depth between the bottom of the groove and the seating surface.

Remove burrs on the edges of the seating surface and O-ring groove.

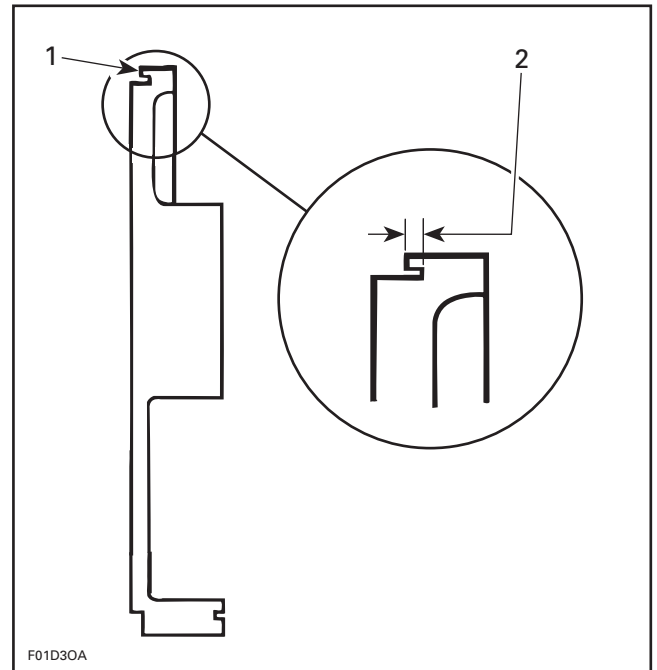

SAME AMOUNT REMOVED FROM COVER SEATING SURFACE AND O-RING GROOVE BASE

1. Cover seating surface
2. O-ring groove depth must be 1.0 ± 0.03 mm (.039 \pm .001 in)

Reverify the clearance.

At assembly the rotary valve timing must remain as per original setting.

NOTE: If rotary valve crankcase surface is worn, it is possible to have it reworked at the factory. Contact your dealer or distributor.

Rotary Valve Shaft Gear Backlash

Remove PTO flywheel guard.

Remove spark plugs, rotary valve cover and valve.

Manually feel backlash at one position, then turn crankshaft about 1/8 turn and recheck. Continue this way to complete one revolution.

Backlash must be even at all positions. Otherwise overhaul engine to find which part is faulty (gear, rotary valve shaft or crankshaft with excessive deflection).

Section 03 ENGINE

Sub-Section 07 (ROTARY VALVE)

DISASSEMBLY

3, Rotary Valve Shaft

To remove the rotary valve shaft assembly, first remove snap ring no. 4 from crankcase.

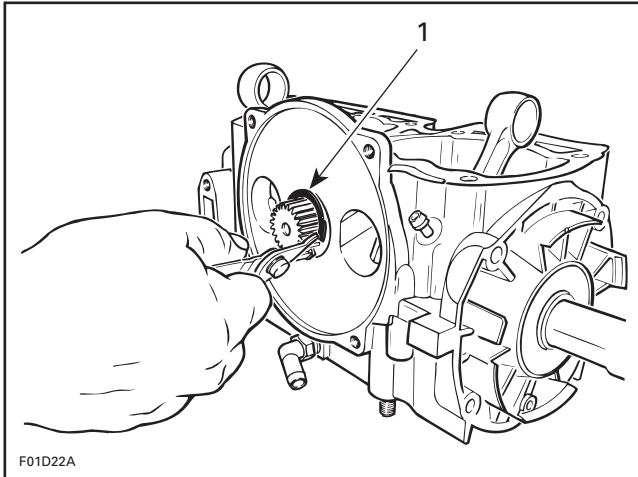

1. Removing snap ring

▼ CAUTION

Bottom end must be opened to remove rotary valve shaft.

To remove rotary valve shaft, use the appropriate puller (P/N 290 876 488).

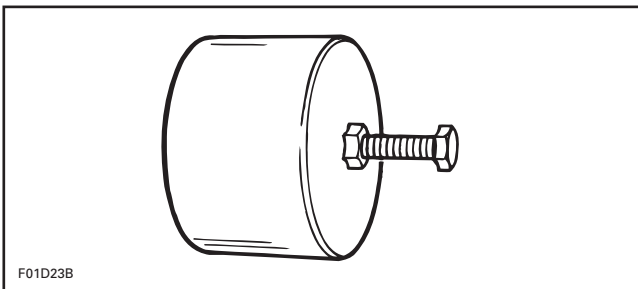

F01D23B

Place puller over rotary valve shaft end and screw on puller bolt into shaft. While retaining bolt with a wrench, turn puller nut CLOCKWISE until shaft comes out.

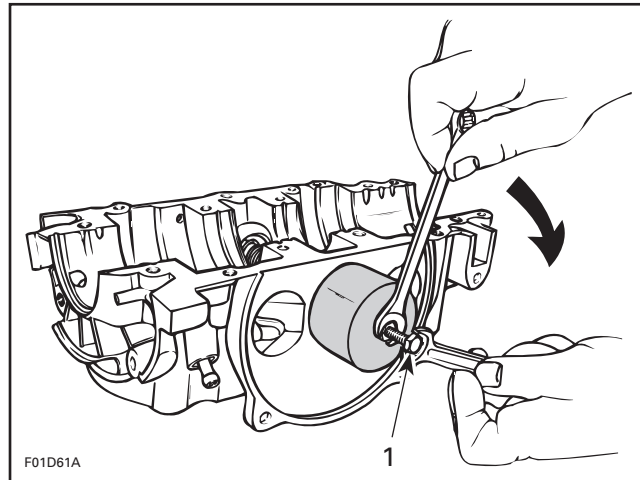

1. Hold bolt

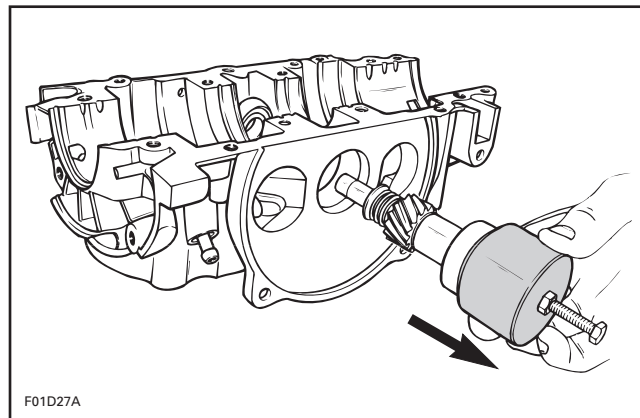

F01D27A

5,6, Circlip and Spring Seat

If it is necessary to disassemble components of rotary valve shaft assembly, use seat to compress spring and remove circlips.

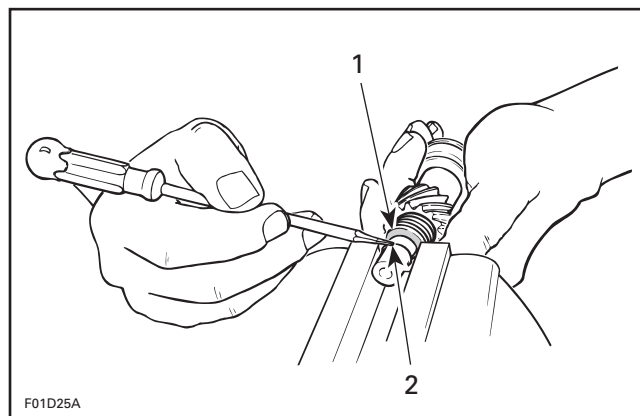

1. Compress seat
2. Remove circlips

8, Bearing

To remove bearing use a bearing extractor such as Snap-on no CJ-950 as illustrated. Slide off distance sleeve, remove snap ring no. 7 and press shaft out.

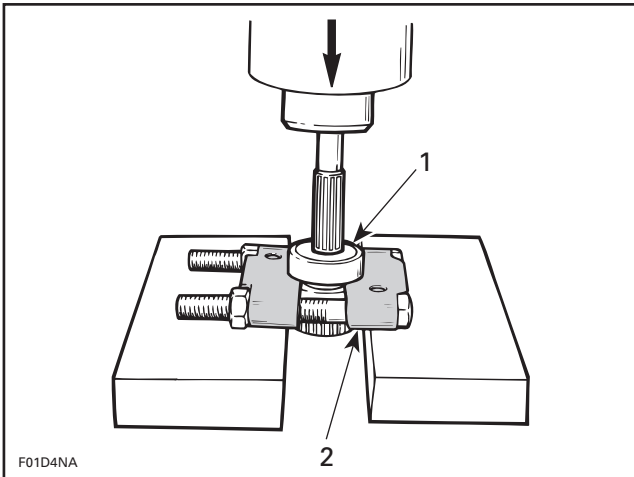

1. Bearing
2. Bearing extractor Snap-on CJ-950

▼ **CAUTION**

Ensure that rotary valve shaft is perfectly perpendicular with press tip.

9, Bearing

▼ **CAUTION**

Do not remove plug against bearing in upper crankcase half.

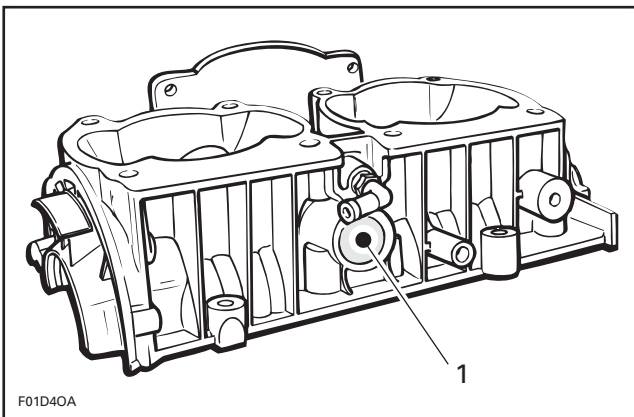

1. Do not remove this plug

End bearing can be easily removed using the following suggested tool.

Snap-on hammer puller including:

- | | |
|--------|---------|
| Handle | CJ93-1 |
| Hammer | CJ125-6 |
| Claws | CJ93-4 |

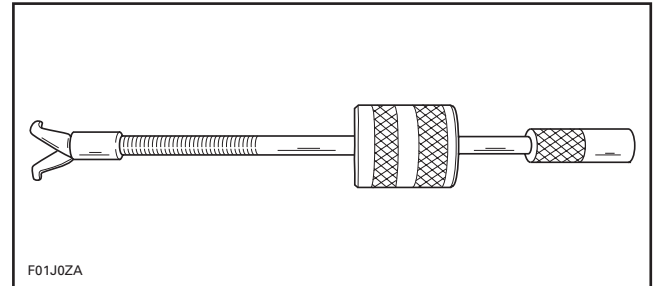

Close puller claws so that they can be inserted in end bearing. Holding claws, turn puller shaft clockwise so that claws open and become firmly tight against bearing.

Slide puller sleeve outwards and tap puller end. Retighten claws as necessary to always maintain them tight against bearing. Continue this way until bearing completely comes out.

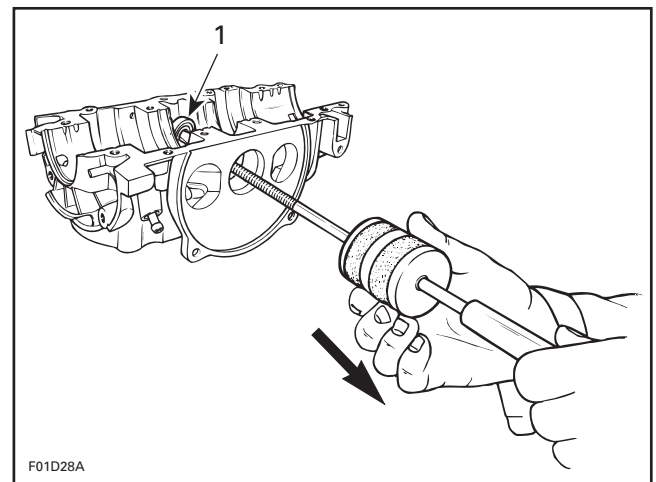

1. End bearing

CLEANING

Discard all seals and O-rings.

Clean all metal components in a solvent.

Clean oil passages and make sure they are not clogged.

Clean rotary valve shaft and inside of distance sleeve no. 14.

Section 03 ENGINE

Sub-Section 07 (ROTARY VALVE)

INSPECTION

1, Rotary Valve Cover

Inspect rotary valve cover for warpage. Small deformation can be corrected by surfacing with fine sand paper on a surface plate. Surface part against oiled sand paper.

8,9 Bearing

Inspect bearings. Check for scoring, pitting, chipping or other evidence of wear. Make sure plastic cage (on bigger bearing) is not melted. Rotate them and make sure they turn smoothly.

10, Gear

Visually check gear wear pattern. It should be even on tooth length all around. Otherwise it could indicate a bent shaft, check deflection. Replace gear if damaged.

Check for presence of brass filings in gear housing.

Rotary Valve Shaft Deflection

Deflection is measured with a dial gauge. Install rotary valve shaft in crankcase half, without its gear.

NOTE: End bearing must be in crankcase half.

Measure shaft deflection next to gear splines.

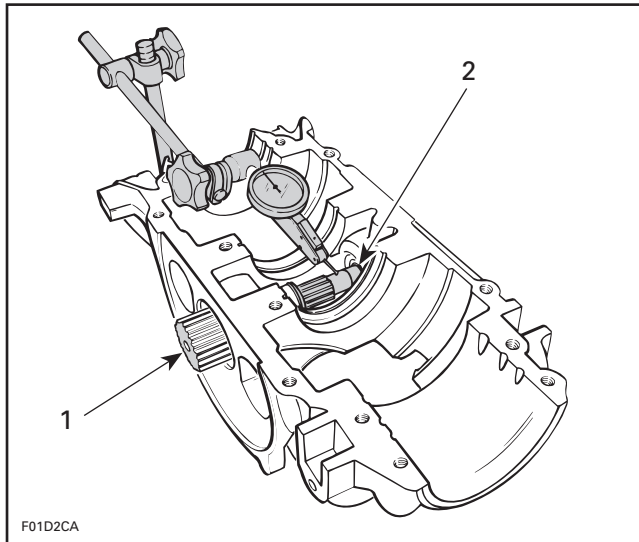

1. Rotary valve shaft
2. End bearing in place

Deflection must not exceed 0.08 mm (.003 in). Replace shaft as necessary.

ASSEMBLY

Assembly is essentially the reverse of disassembly procedures. However pay particular attention to the following.

9, Bearing

To install end bearing in crankcase, use the appropriate pusher according to the engine.

ENGINE	PUSHER
717/717D	P/N 290 876 500
787	P/N 290 876 501

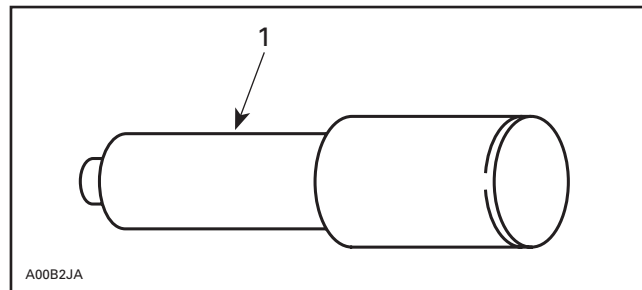

1. Pusher (P/N 290 876 500)

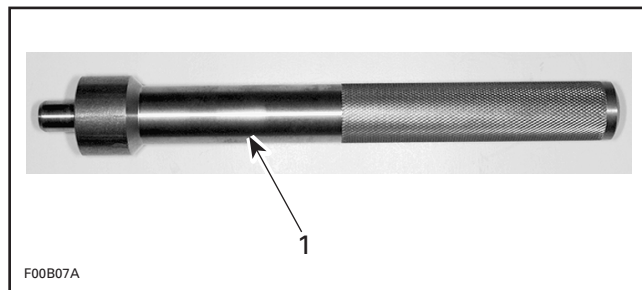

1. Pusher (P/N 290 876 501)

Position ball bearing shielded side towards rotary valve.

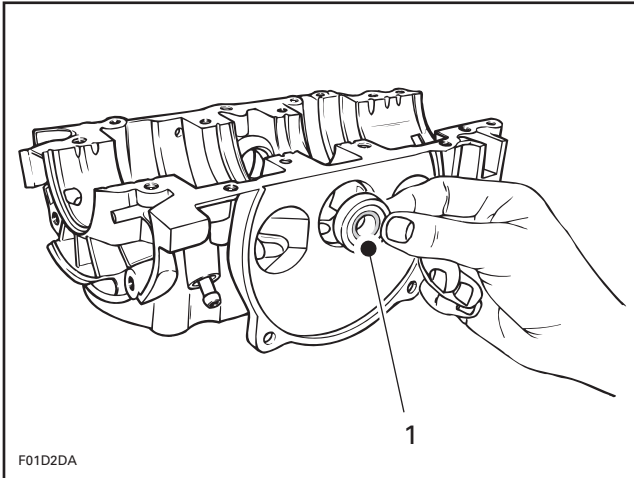

1. Shield side (toward gear)

Push bearing until it stops on its seat.

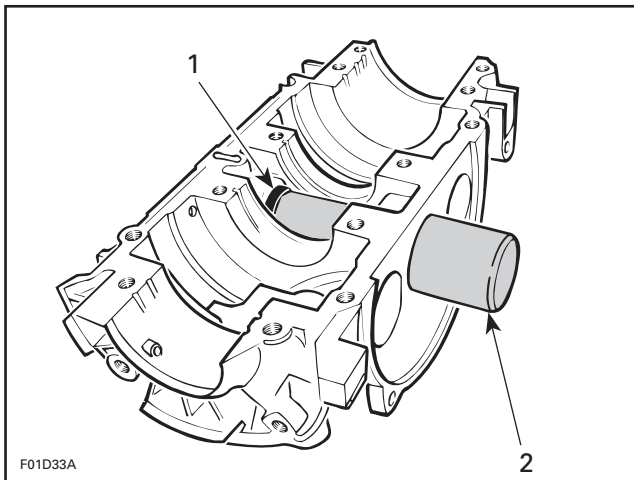

1. Bearing
 2. Pusher

11, Seal

Apply lithium grease on seal lips. Position seal with shielded portion against shaft splines.

8, Bearing

Install ball bearing as illustrated.

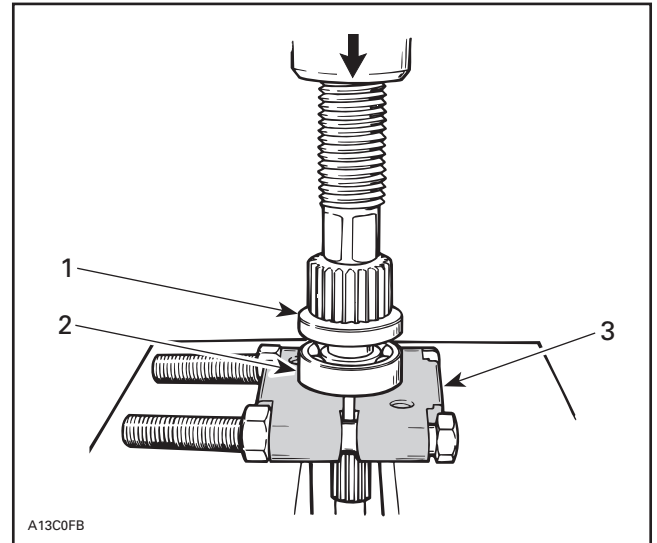

1. Seal
 2. Ball bearing
 3. Bearing extractor Snap-on CJ-950

Install shim no. 15, snap ring no. 7 and slide distance sleeve no. 14 on shaft.

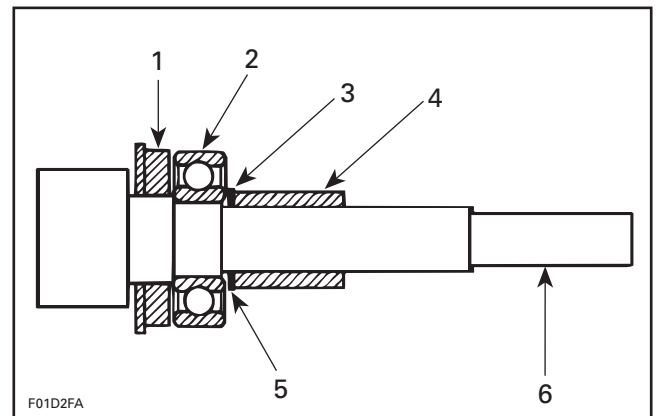

1. Seal
 2. Ball bearing
 3. Snap ring
 4. Distance sleeve
 5. Shim 0.5 mm (.020 in)
 6. Rotary valve shaft

3, Rotary Valve Shaft Assembly

▼ CAUTION

Crankcase halves must be separated and crankshaft must not be present to install rotary valve shaft assembly in crankcase.

Section 03 ENGINE

Sub-Section 07 (ROTARY VALVE)

717 Engines

To install rotary valve shaft in crankcase, use a pusher (P/N 290 876 605).

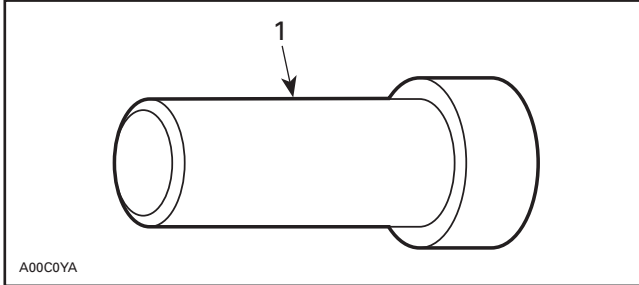

1. Pusher

Push shaft until its stops on bearing seat.

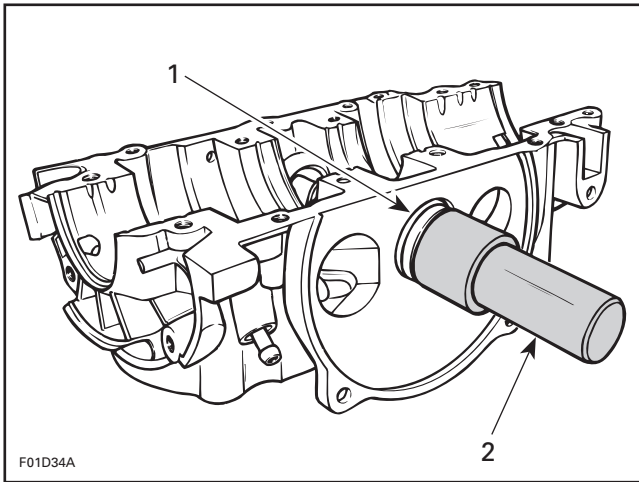

1. Rotary valve shaft
2. Push shaft until it stops

787 Engine

To install rotary valve shaft in crankcase, use a pusher (P/N 290 876 609) and handle (P/N 290 877 650).

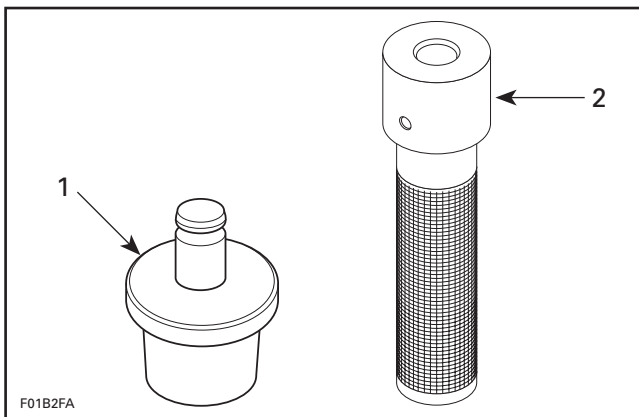

1. Pusher
2. Handle

Push shaft until it stops on bearing seat.



F01D80A

All Engines

4, Snap Ring

Position snap ring so that its sharp edge faces outwards.

13, Rotary Valve

The rotary valve controls the opening and closing of the inlet ports. Therefore its efficiency will depend on the precision of its installation.

IDENTIFICATION OF THE ROTARY VALVE

Engine	Rotary Valve P/N	Valve Duration
717D	290 924 504	132°
717/787	290 924 502	159°

There is no identification code on the valves. To find out the duration, place an angle finder on the valve and measure the valve cut-out angle or use the following template.

TEMPLATE

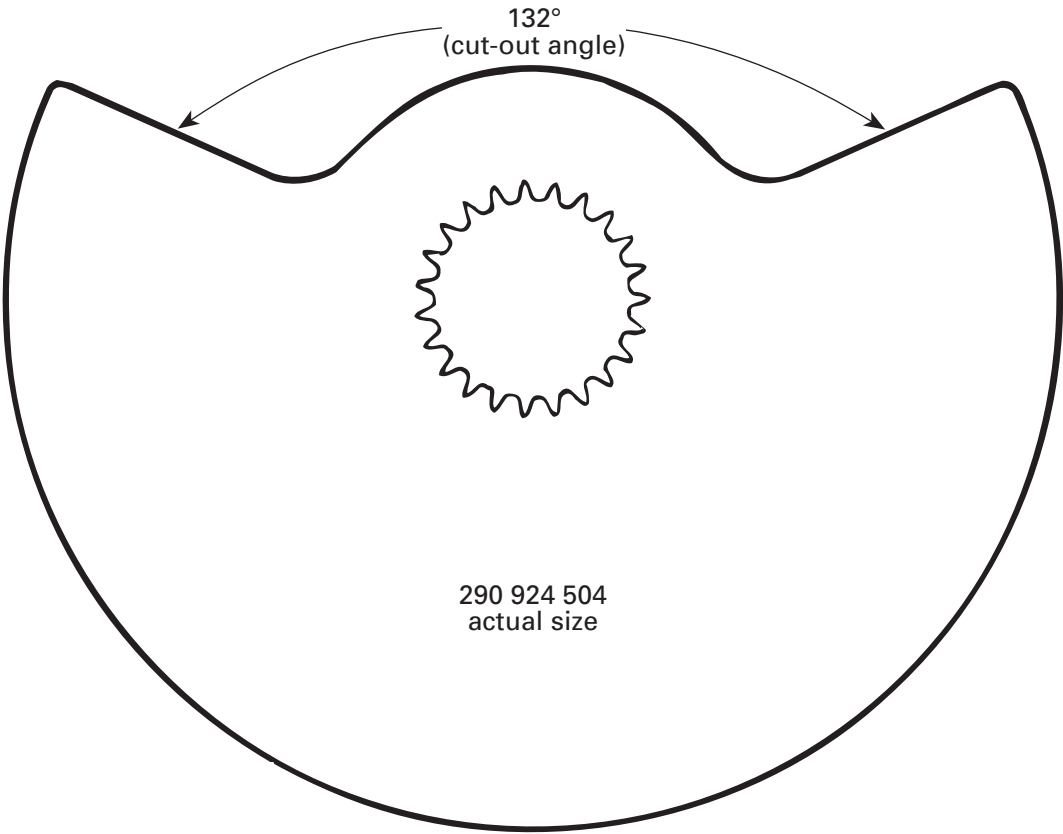
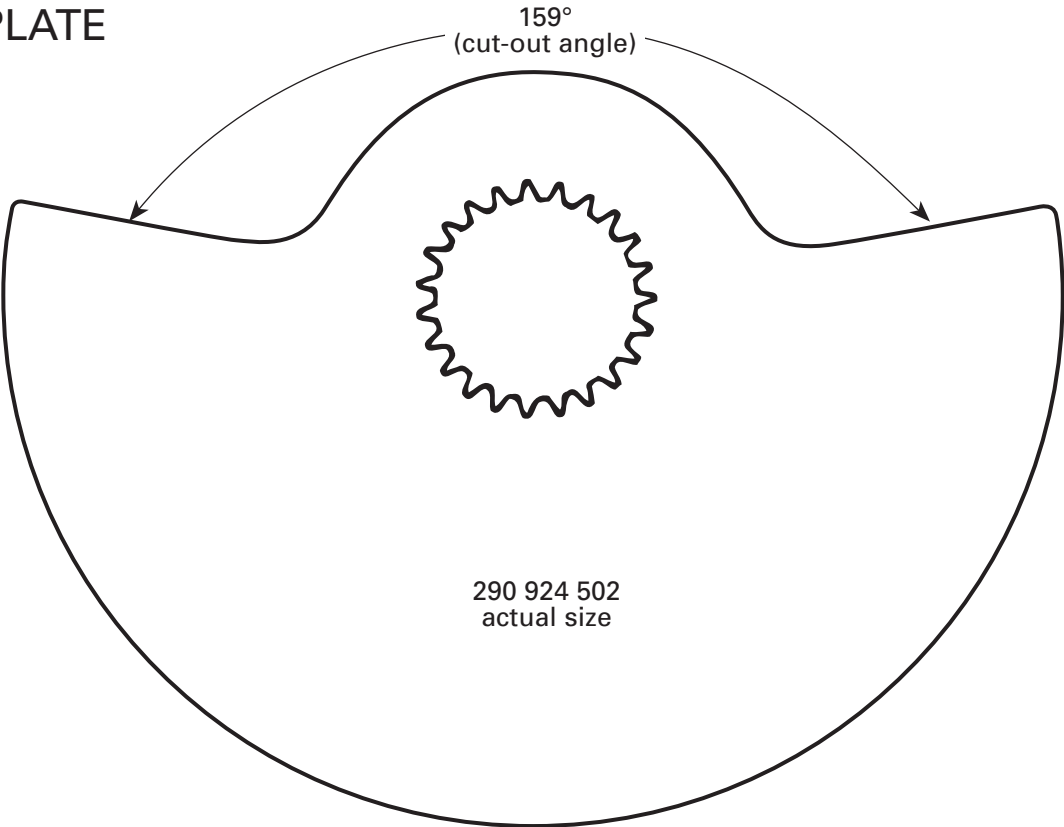

Section 03 ENGINE

Sub-Section 07 (ROTARY VALVE)

ROTARY VALVE TIMING

CAUTION

Never use the ridge molded in crankcase as a timing mark.

The following tools are required to measure rotary valve opening and closing angles in relation with MAG side piston.

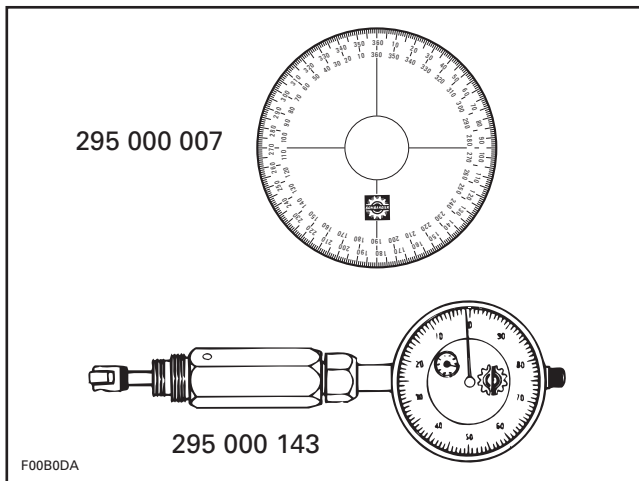

Rotary valve must be set so that timing occurs as follows:

ENGINE	TIMING	
	OPENING BTDC	CLOSING ATDC
717D	130° ± 5	55° ± 5
717	147° ± 5	65.5° ± 5
787	146.5° ± 5	64° ± 5

For the following instructions, let's use these specifications as example:

OPENING: 147° BTDC

CLOSING: 65° ATDC

Proceed as follows:

- Turning crankshaft, bring **MAG side** piston to Top Dead Center using a TDC gauge.

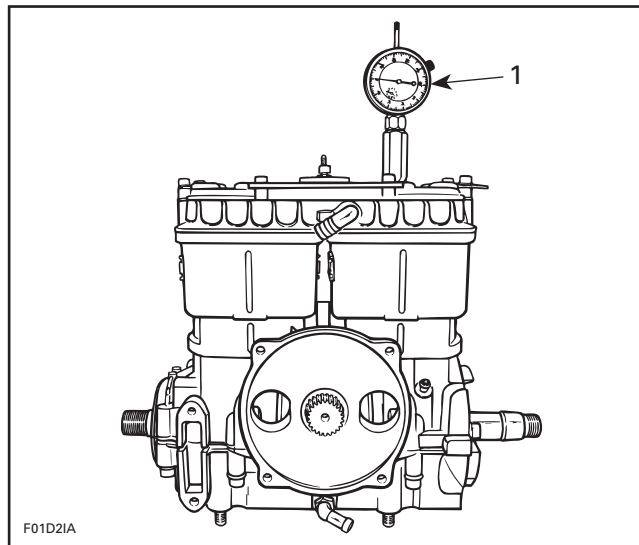

1. Bring piston to TDC

- For **opening** mark, first align 360° line of degree wheel with **BOTTOM** of **MAG side** inlet port. Then, find 147° line on degree wheel and mark crankcase at this point.

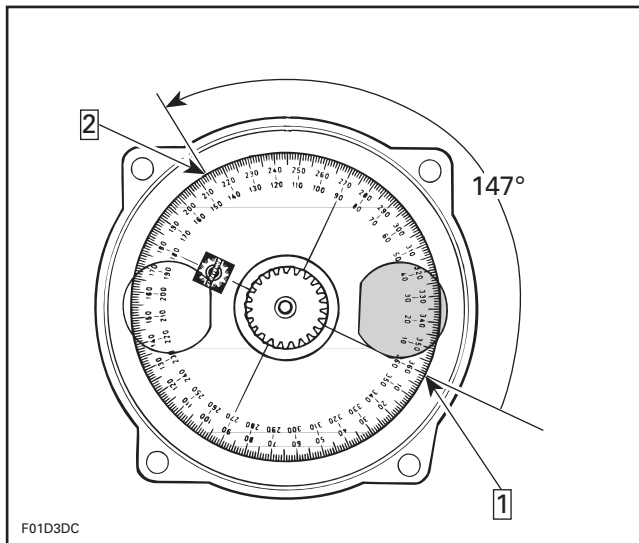

OPENING MARK

Step **1**: Bottom of MAG inlet port.

Align 360° line of degree wheel

Step **2**: Find 147° on degree wheel and mark here

NOTE: Do not rotate the crankshaft.

- For **closing** mark, first align 360° line of degree wheel with **TOP** of **MAG side** inlet port. Then, find 65° line on degree wheel and mark crankcase at this point.

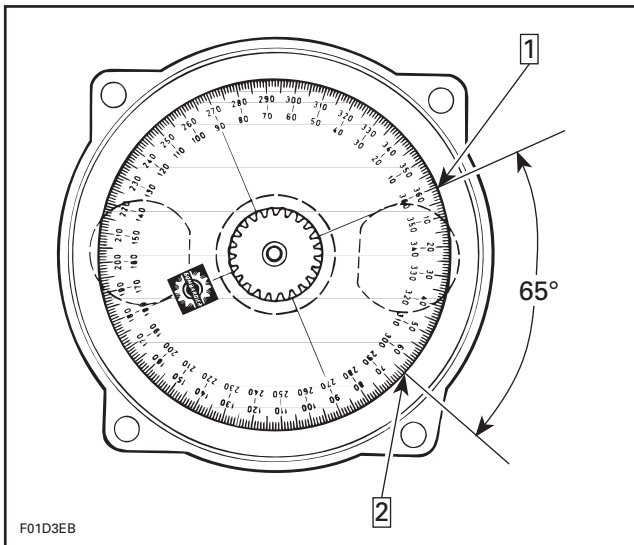

CLOSING MARK

Step **1** : Top of MAG inlet port.

Align 360° line of degree wheel

Step **2** : Find 65° on degree wheel and mark here

- Remove degree wheel.
- Position rotary valve on shaft splines to have edges as close as possible to these marks with the MAG piston at TDC.

NOTE: Rotary valve is asymmetrical. Therefore, try flipping it over then reinstall on splines to obtain best installation position.

Apply BOMBARDIER-ROTAX injection oil on rotary valve before reassembling rotary valve cover.

- Remove TDC gauge.

1, Rotary Valve Cover

Install O-ring **no. 12** and cover then torque screws **no. 2** to 20 N•m (15 lbf•ft) in a criss-cross sequence.

NOTE: For the 717D engine (SP model), install engine in watercraft first; then, install rotary valve cover, intake manifold and carburetor as an assembly.

EXHAUST SYSTEM

SP, GS, GSI, GTS and GTI Models

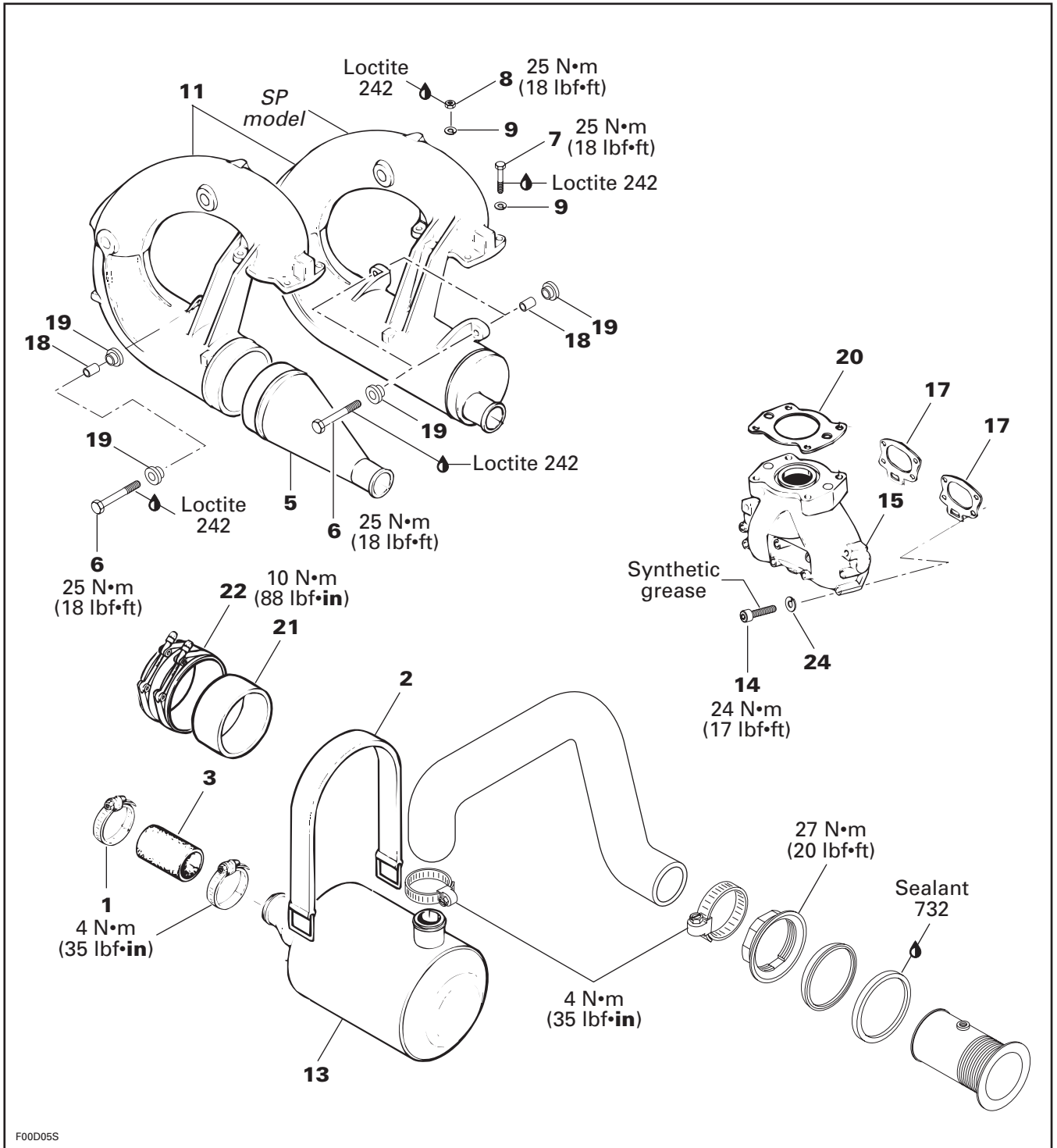

Section 03 ENGINE

Sub-Section 08 (EXHAUST SYSTEM)

HX Model

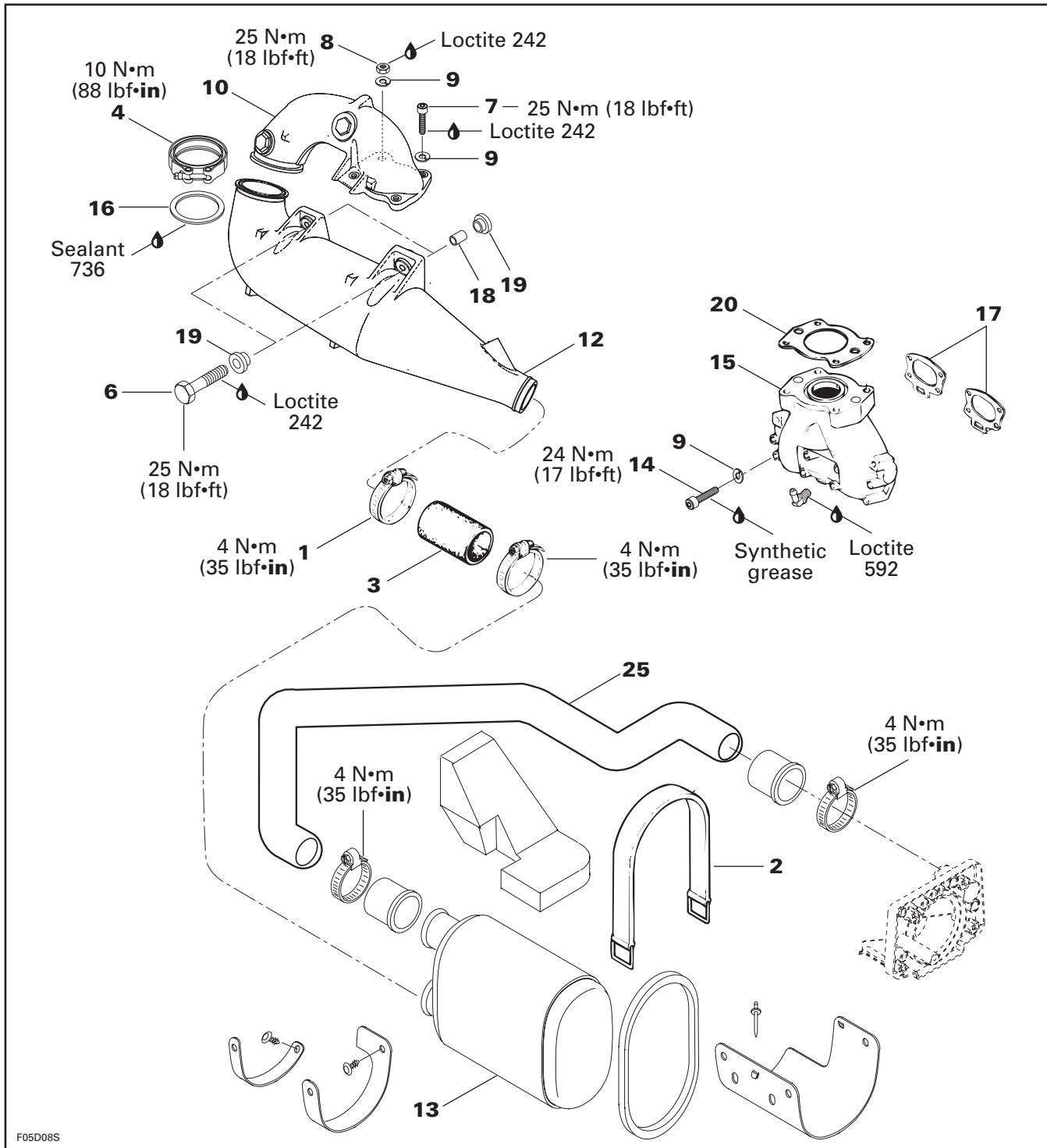

F05D08S

SPX, XP, GSX and GTX Models

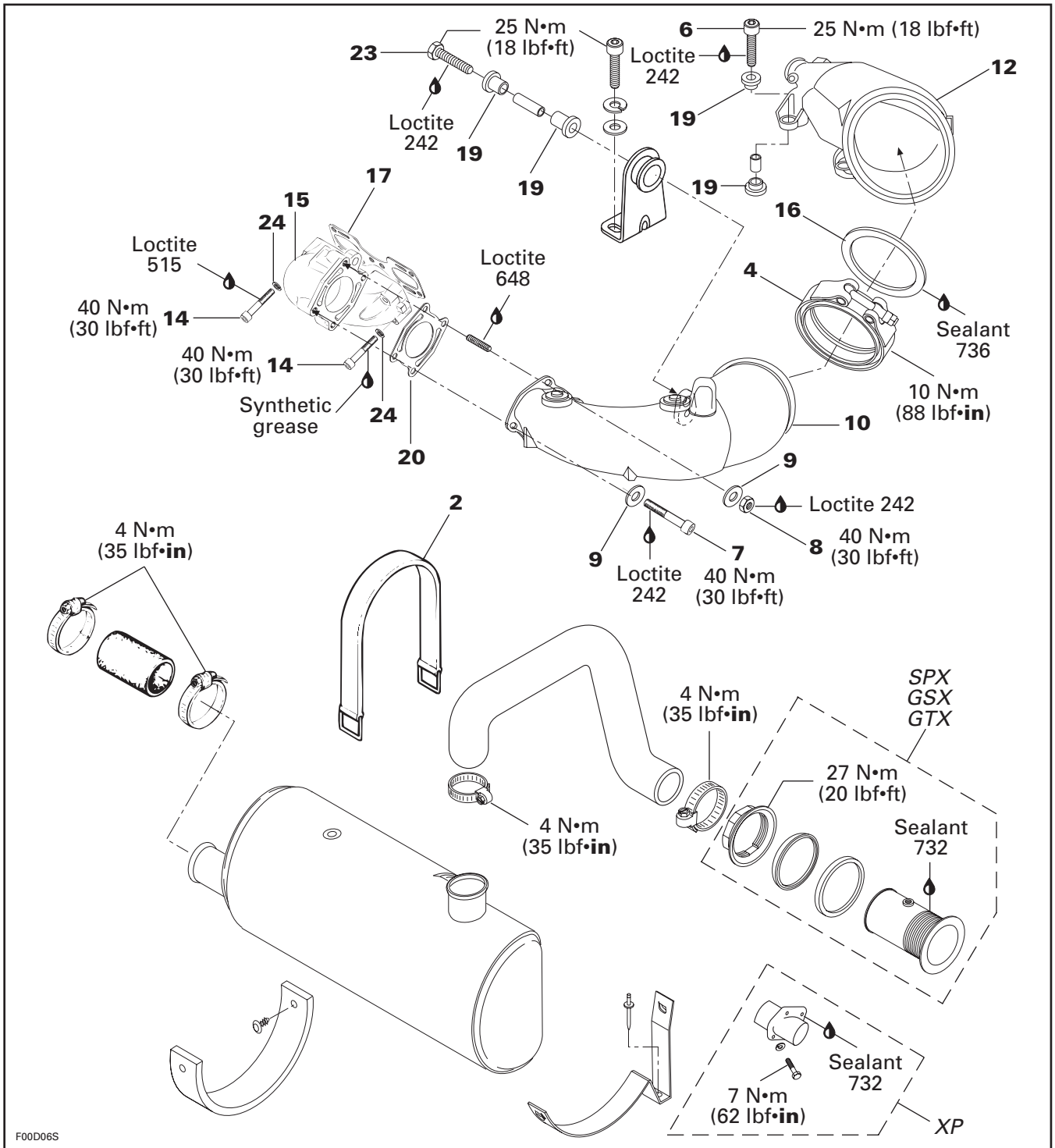

Section 03 ENGINE

Sub-Section 08 (EXHAUST SYSTEM)

TUNED PIPE REMOVAL

SP, GS and GSI Models

Remove seat.

Remove air vent tube support from body opening.

GTS and GTI Models

Remove seat.

Remove seat support (GTI model).

SP, GS, GSI, GTS and GTI Models

Disconnect water inlet hose and water injection hose.

Disconnect tuned pipe bleed hose.

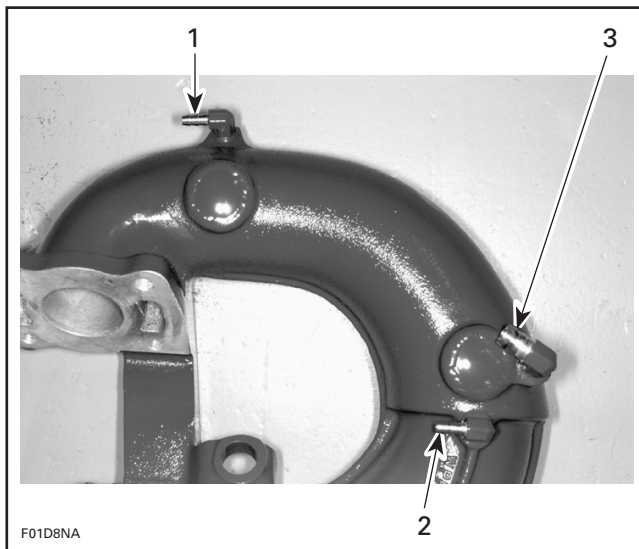

TYPICAL

1. Bleed hose removed
2. Injection hose removed
3. Inlet hose removed

Cut tie rap retaining together engine and tuned pipe bleed hoses (if applicable).

Loosen exhaust hose collar **no. 1** at tuned pipe outlet.

Disconnect strap **no. 2** retaining muffler **no. 13**.

Remove exhaust hose **no. 3** from tuned pipe by pulling muffler.

Remove clamp **no. 22** from tuned pipe (except SP model).

Remove tuned pipe cone **no. 5** (except SP model).

Remove tuned pipe retaining screw(s) **no. 6** from exhaust manifold side.

Remove screws **no. 7**, nut **no. 8** and flat washers **no. 9** from tuned pipe flange.

NOTE: Slightly lift tuned pipe to release nut as necessary. Take care not drop nut and flat washer.

Withdraw tuned pipe head **no. 11** in a forward and rotating movement.

HX and XP Models Only

NOTE: It is possible to remove the tuned pipe head and cone at the same time. If such is the case, disconnect only the water outlet hose at cylinder head and do not remove the clamp retaining tuned pipe head to tuned pipe cone.

Disconnect water inlet hose at tuned pipe head **no. 10**.

Disconnect water injection hose at tuned pipe cone **no. 12**.

Disconnect bleed hose on top of tuned pipe head **no. 10**.

Remove clamp **no. 4** retaining tuned pipe head **no. 10** to tuned pipe cone **no. 12** (if desired).

Remove screws **no. 7**, nut **no. 8** and flat washers **no. 9** from tuned pipe head flange.

Remove tuned pipe head **no. 10**.

Loosen exhaust hose collar **no. 1** at tuned pipe cone outlet.

Remove two screws **no. 6** retaining tuned pipe cone from exhaust manifold.

SPX and GSX Models

Remove seat.

Remove air vent tube support from body opening.

SPX Model Only

Remove electrical box from watercraft. Refer to ENGINE REMOVAL AND INSTALLATION 03-02.

SPX, XP, GSX and GTX Models

Disconnect water supply hose and water injection hose at tuned pipe head.

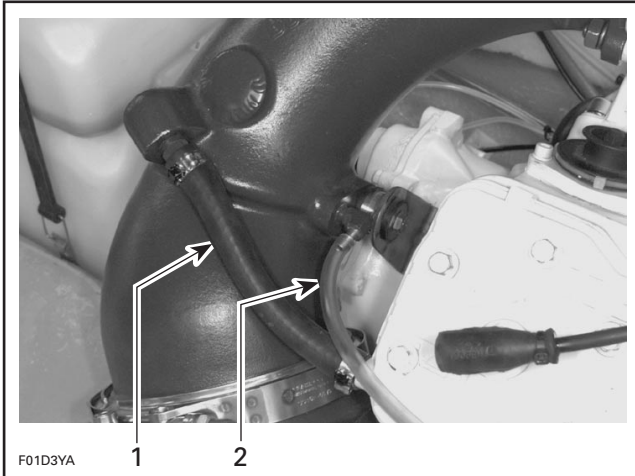

1. Water supply hose
2. Water injection hose

Loosen exhaust hose collar **no. 1** at tuned pipe cone outlet.

Remove clamp **no. 4** securing tuned pipe cone to tuned pipe head.

Remove screws **no. 7** and nut **no. 8** with flat washers **no. 9** at tuned pipe head flange.



Remove retaining screw **no. 23** of tuned pipe head.

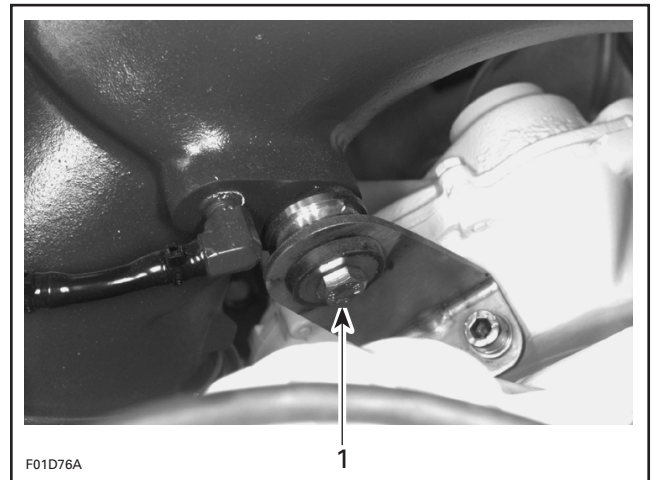

1. Screw

Remove tuned pipe head **no. 10**.

Remove both screws **no. 6** retaining tuned pipe cone to engine.

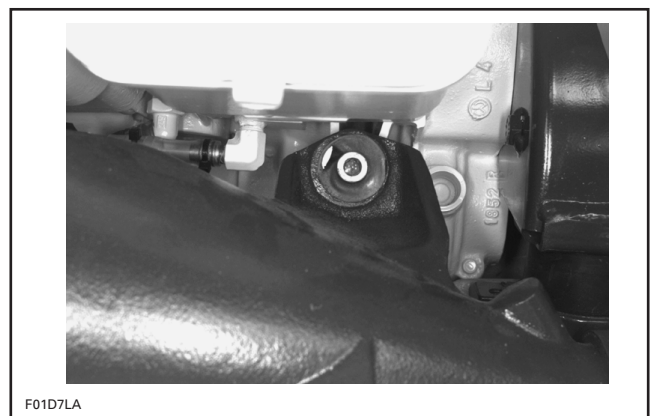

Section 03 ENGINE

Sub-Section 08 (EXHAUST SYSTEM)

SPX Model Only

Move tuned pipe cone no. 12 in front of bilge between body and fuel tank.

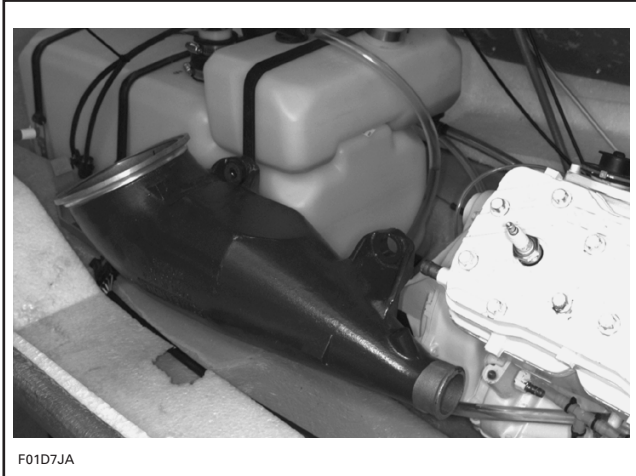

F01D7JA

Open storage cover and remove basket. Then, pull out tuned pipe cone no. 12 through storage compartment opening.

XP, GSX and GTX Models

Remove tuned pipe cone no. 12 from engine compartment.

EXHAUST MANIFOLD REMOVAL

SPX, XP, GSX and GTX Models

Remove air intake silencer and carburetors. Refer to FUEL SYSTEM 05-03 for proper procedure.

All Models

Remove eight screws no. 14 and lock washers no. 24 then withdraw exhaust manifold.

MUFFLER REMOVAL

All Models Except the HX and XP

Disconnect hoses from muffler.

Disconnect hoses of the water flow regulator valve (787 engines).

Disconnect retaining strap no. 2 of muffler.

Pull muffler no. 13 out of bilge.

HX Model Only

Loosen exhaust hose collar no. 1 at tuned pipe cone outlet (only if tuned pipe cone is not removed).

Remove rear access cover from body.

Disconnect upper exhaust hose no. 25 in front of muffler.

Disconnect both water injection hoses and both water drain hoses from muffler.

Disconnect retaining strap no. 2 of muffler.

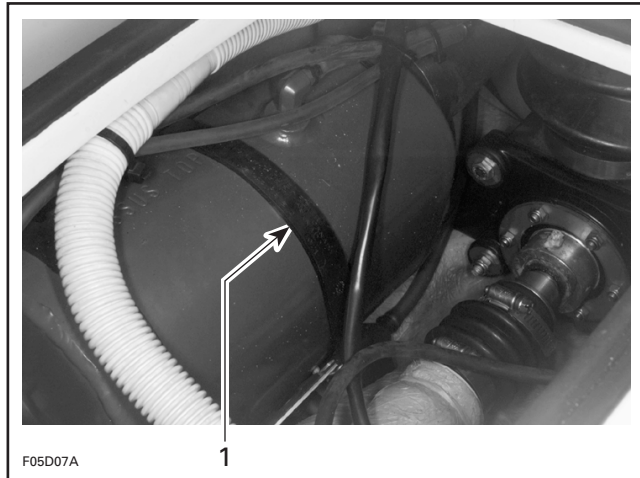

F05D07A

1. Strap

Pull muffler no. 13 out of bilge.

NOTE: Lower exhaust hose of muffler may be disconnected or left with muffler.

TUNED PIPE REPAIR

This procedure is given to repair tuned pipe cracks using T.I.G. welding process.

Procedure

- Sand the cracked area to obtain bare metal.
- Perform a 1.50 mm (1/16 in) depth chamfer over crack.
- Use pure argon gas with 5.55 mm (3/32 in) tungsten electrode (puretung "green", zirtung "brown") and AC current.
- Use a 5.55 mm (3/32 in) aluminum welding rod (no. 4043), to fill crack.
- Sand welding slightly to remove material surplus.

Test

- Use compressed air at 124 kPa (18 PSI) to pressurize tuned pipe.

NOTE: Prior to verify leaks, plug all holes and pressurize tuned pipe while immersing it in water.

 CAUTION
<p>Always ensure water passages are not blocked partially or completely while welding tuned pipe.</p>

INSTALLATION

Installation is essentially the reverse of removal procedures. However, pay particular attention to the following.

15, Exhaust Manifold

Make sure gasket(s) no. 17 are properly positioned prior to finalizing manifold installation.

717 Engines

Apply synthetic grease on threads of screws no. 14.

Install and torque screws no. 14 to 24 N•m (17 lbf•ft) as per following illustrated sequence.

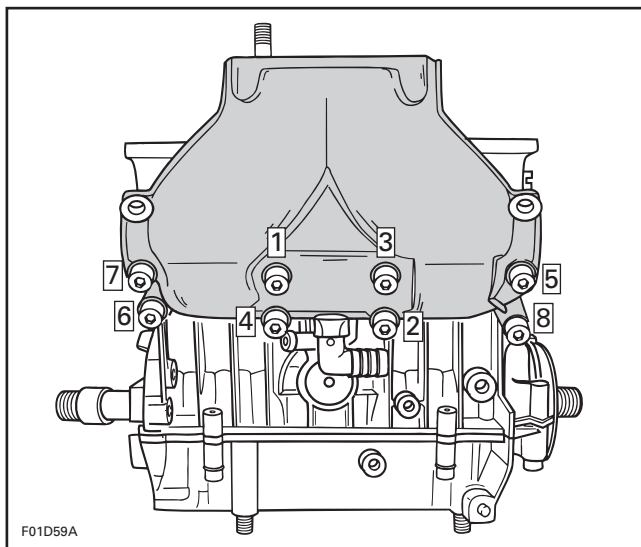

787 Engine

Apply Loctite 515 on two screws no. 14. On the other screws no. 14, apply synthetic grease on threads. Install screws. Refer to the following illustration for proper position of screws to the exhaust manifold.

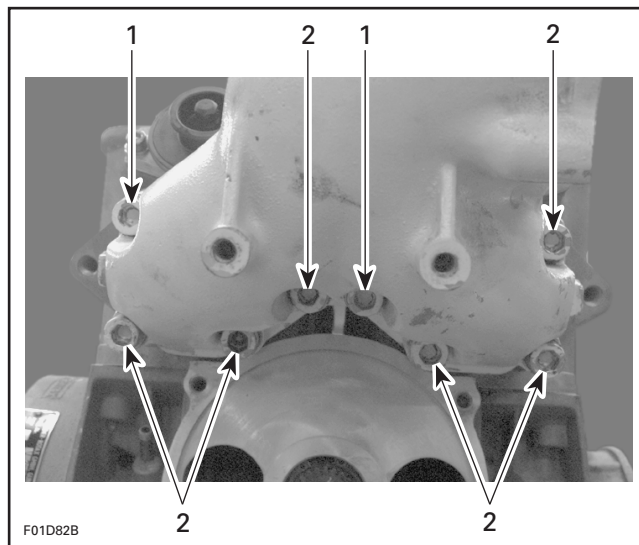

1. Screw with Loctite 515
2. Screw with synthetic grease

Torque exhaust manifold screws to 24 N•m (17 lbf•ft) as per following illustrated sequence. Repeat the procedure, retightening screws to 40 N•m (30 lbf•ft).

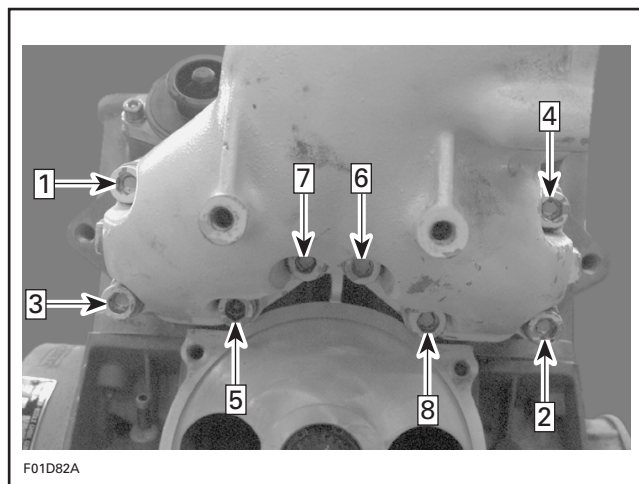

10,11,12, Tuned Pipe

HX, GSX and GTX Models

Make sure to install the sealing ring no. 16 on tuned pipe cone if it was removed.

Section 03 ENGINE

Sub-Section 08 (EXHAUST SYSTEM)

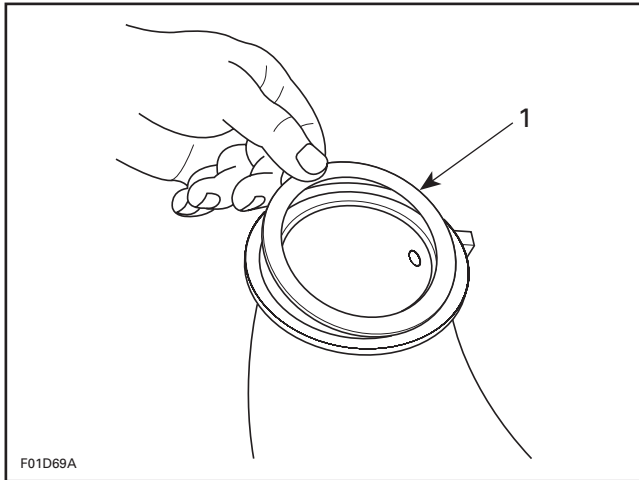

TYPICAL

1. Sealing ring

Apply a thin layer of heat resistant sealant (P/N 413 709 200) all around sealing ring.

All Models

Ensure rubber bushings **no. 19** and sleeve **no. 18** are not damaged and are properly installed into tune pipe support(s).

▼ CAUTION

Damage to bushings and/or sleeve will eventually cause stress to tune pipe and may cause cracking.

Make sure that gasket **no. 20** is properly located on exhaust manifold prior to finalizing pipe installation.

4,6,7,8,23, Clamp, Screw and Nut

Apply Loctite 242 (blue) on nut **no. 8** and screws **no. 6** and **no. 7**. Hand-tighten nut **no. 8** and screws **no. 6** and **no. 7** and assure that tuned pipe bushing(s) **no. 19** rests against manifold.

Refer to the following illustration for the torquing sequence.

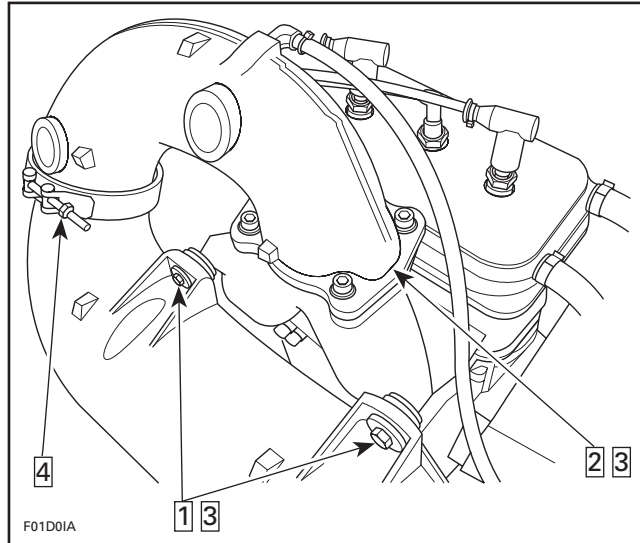

TYPICAL

Step **1**: Torque screw(s) of tuned pipe cone to 12 N•m (9 lbf•ft)

Step **2**: Torque nut and screws of tuned pipe flange in a criss-cross sequence to 12 N•m (9 lbf•ft)

Step **3**: Repeat the torquing sequence by retightening all fasteners to 25 N•m (18 lbf•ft)

Step **4**: Torque clamp to 10 N•m (88 lbf•in) (if applicable)

787 Engines

Torque nut **no. 8** and screws **no. 7** of tuned pipe head flange to 40 N•m (30 lbf•ft).

GS, GSI, GTS and GTI Models

Install tuned pipe cone **no. 5** with collar **no. 21** and clamp **no. 22**.

Position clamp **no. 22** as illustrated. Do not tighten clamp yet.

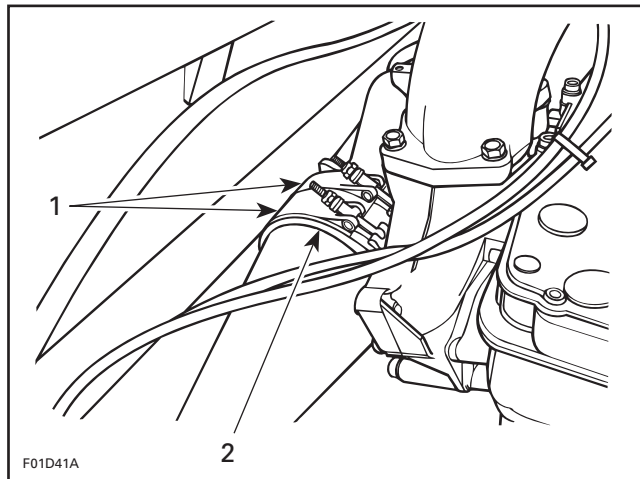

1. Clamp
2. Exhaust collar

With hose removed, align cone outlet with muffler inlet.

NOTE: Due to exhaust cone angle, it may have to be rotated to obtain alignment.

Push cone **no. 5** until it touches tuned pipe, then tighten exhaust clamp **no. 22** and torque to 10 N•m (88 lbf•in).

 CAUTION

There must be no gap between tuned pipe cone and tuned pipe head.

NOTE: Exhaust clamp nuts should be tightened alternately to assure no leakage and to obtain specified torque.

TABLE OF CONTENTS

COMPONENTS	04-02-1
GENERAL	04-02-6

CIRCUIT	04-03-1
GENERAL	04-03-1
717 ENGINE COOLING SYSTEM	04-03-4
787 ENGINE COOLING SYSTEM	04-03-5

COMPONENTS

SP and GTS Models

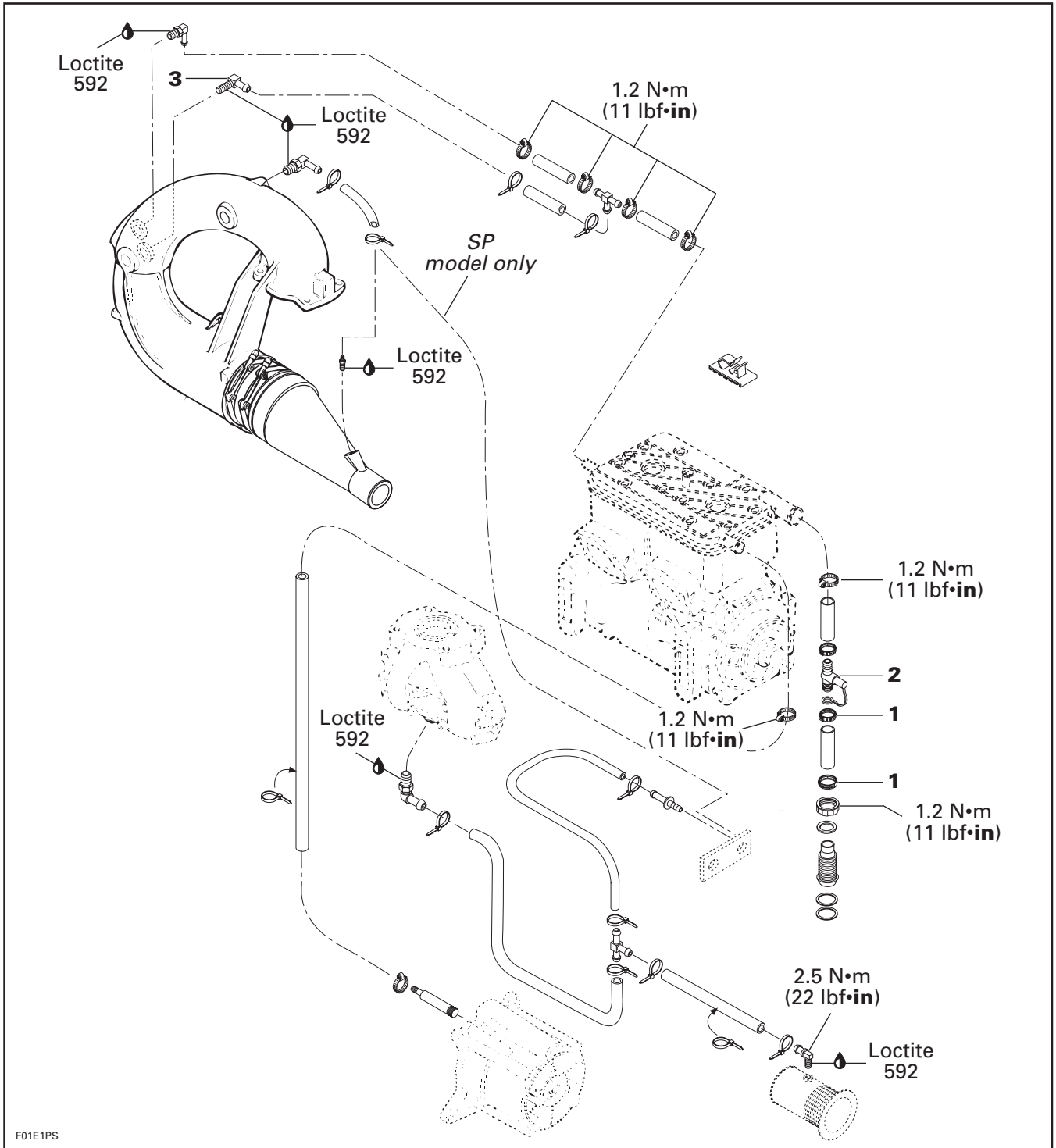

Section 04 COOLING SYSTEM

Sub-Section 02 (COMPONENTS)

SPX Model

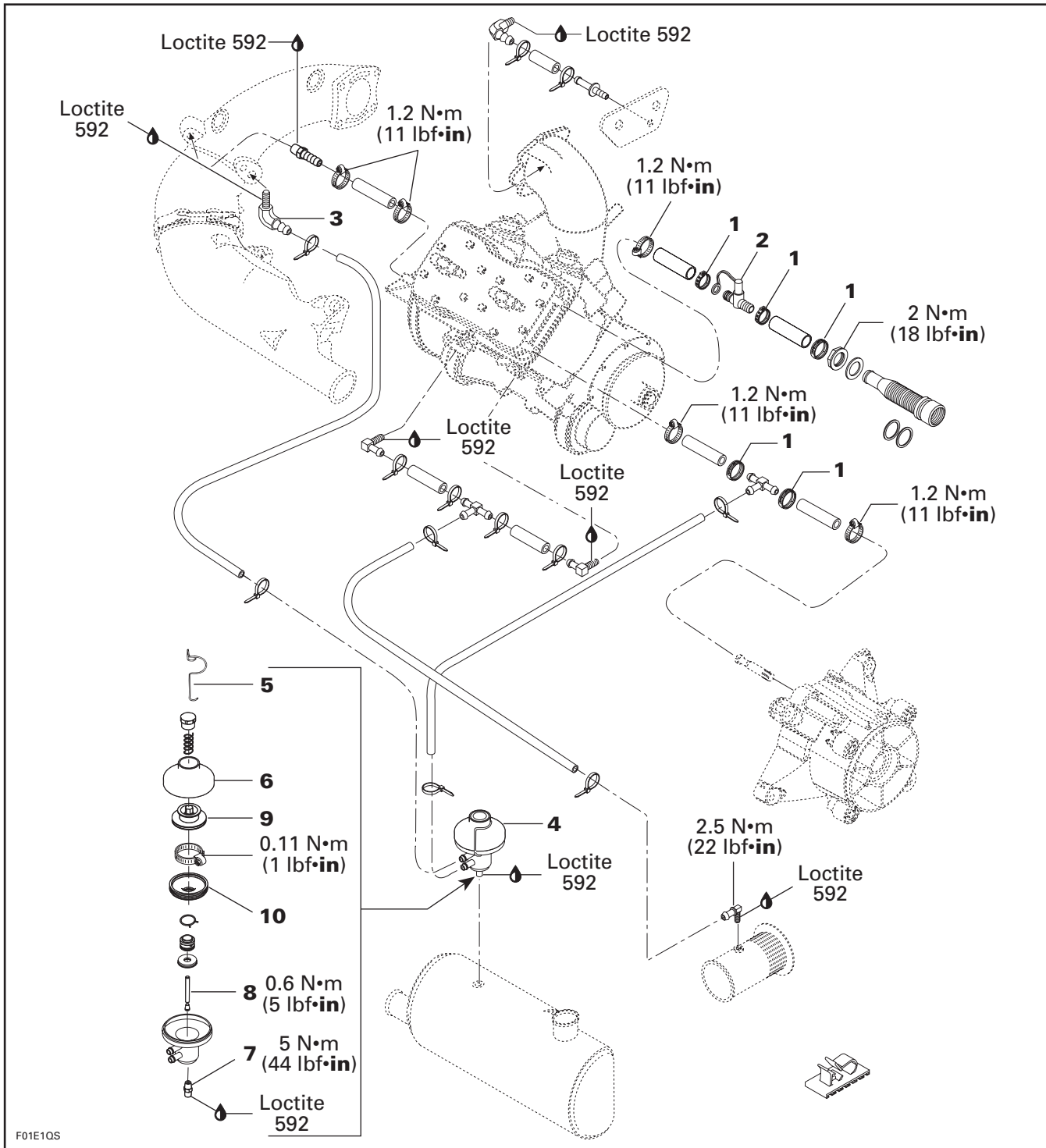

F01E1QS

Section 04 COOLING SYSTEM
Sub-Section 02 (COMPONENTS)

GS, GSI and GTI Models

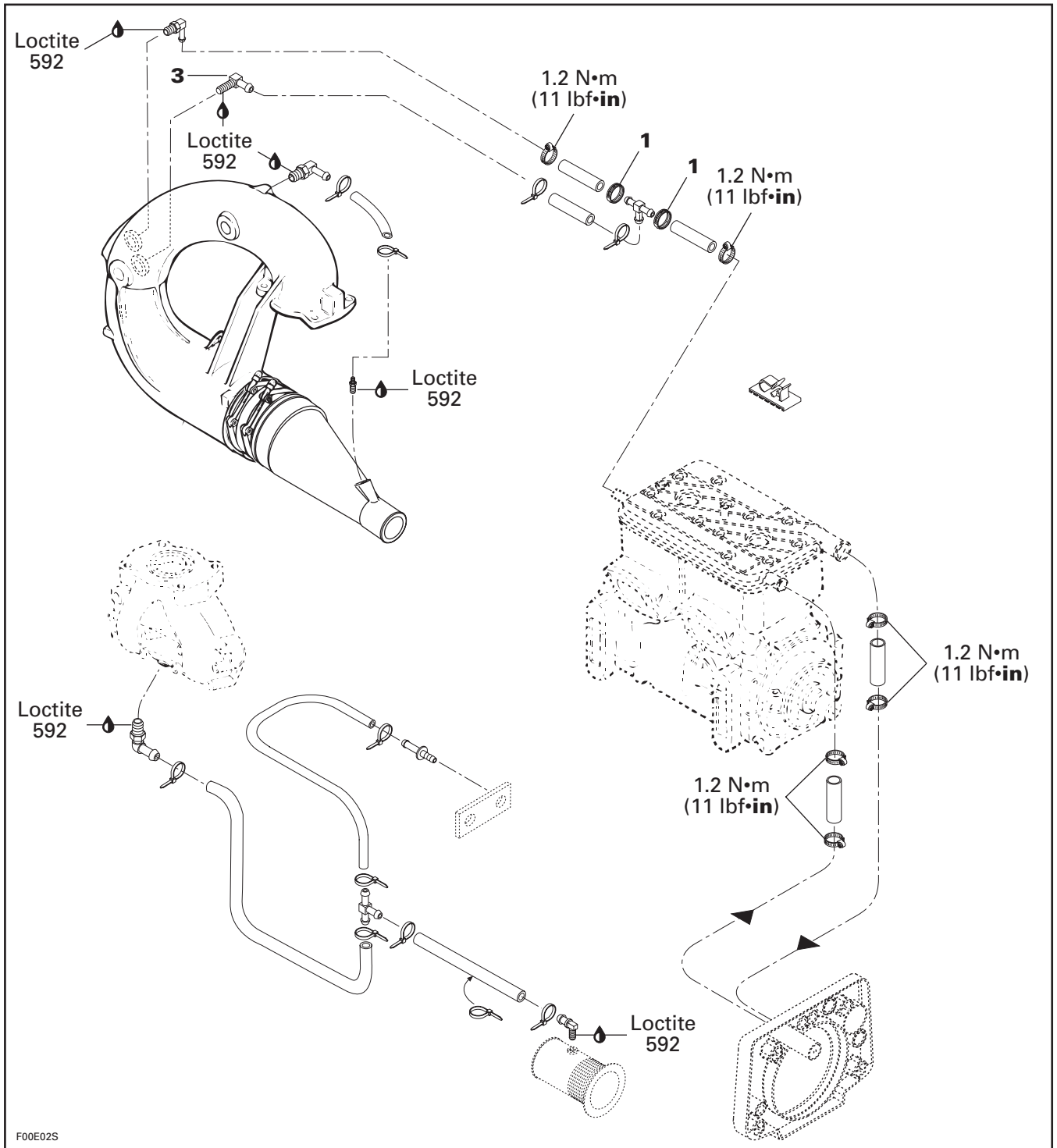

Section 04 COOLING SYSTEM

Sub-Section 02 (COMPONENTS)

XP, GSX and GTX Models

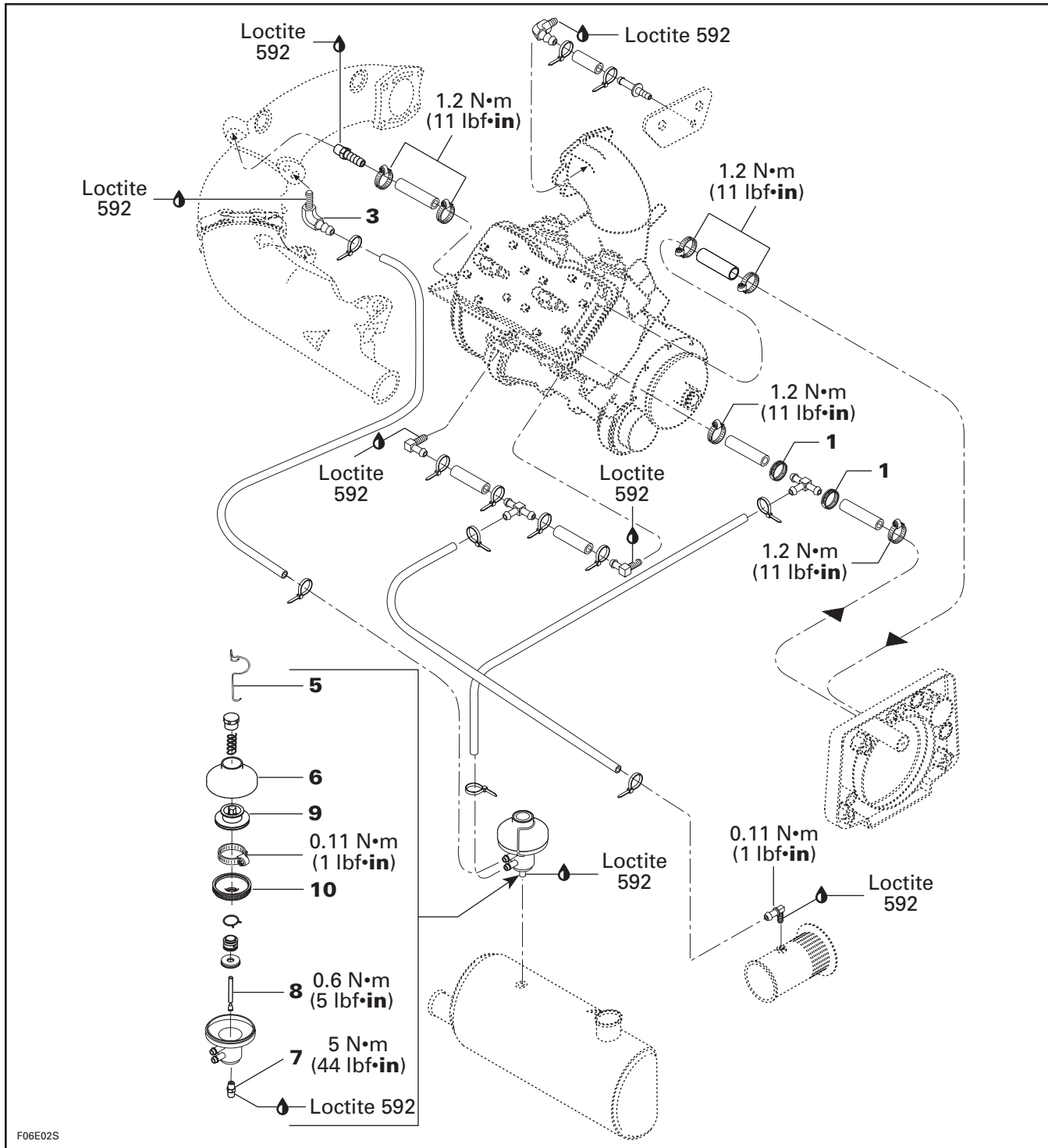

Section 04 COOLING SYSTEM
Sub-Section 02 (COMPONENTS)

HX Model

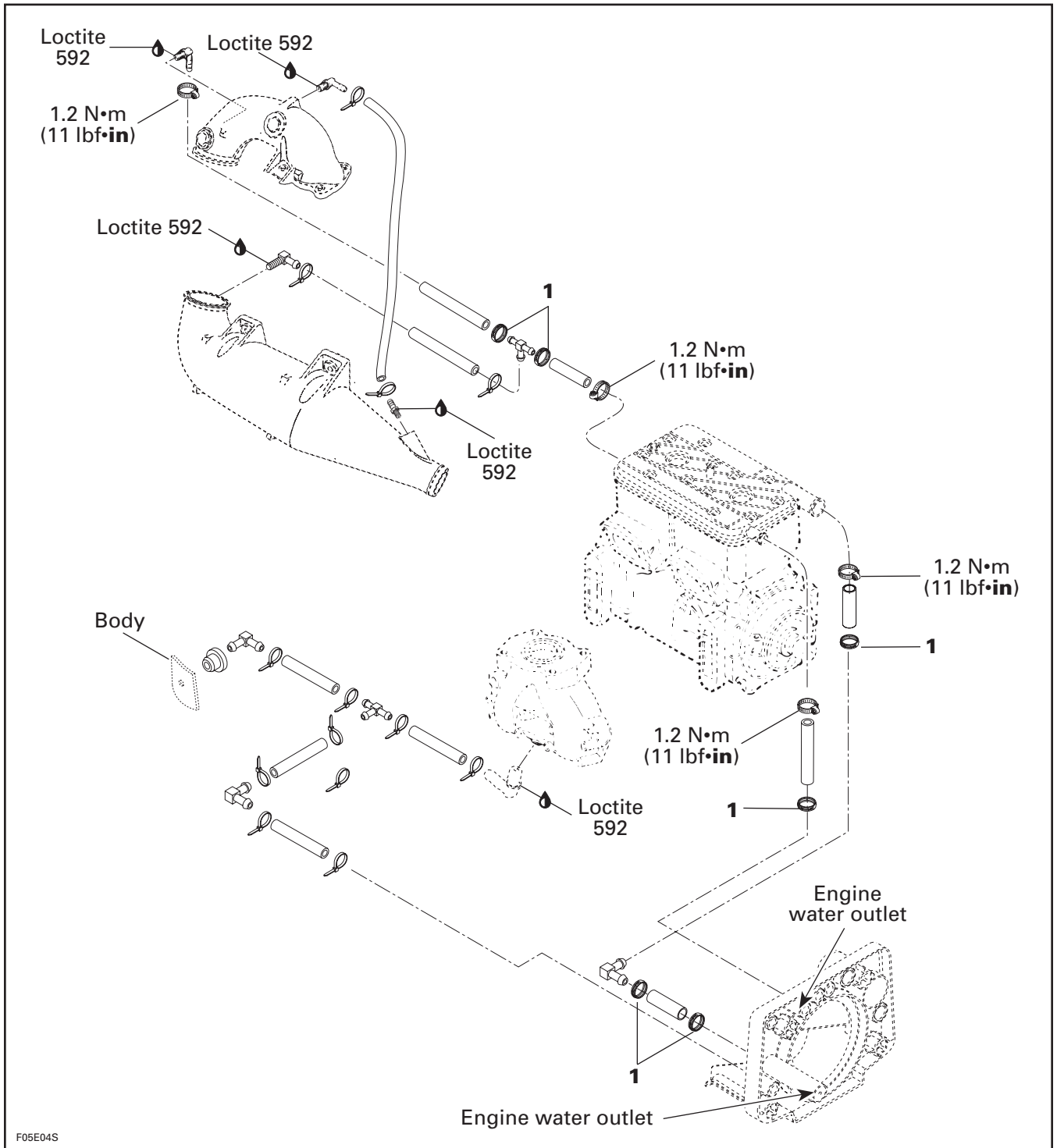

Section 04 COOLING SYSTEM

Sub-Section 02 (COMPONENTS)

GENERAL

▼ CAUTION

All hoses and fittings of the cooling system have calibrated inside diameters to assure proper cooling of the engine. Always replace using appropriate Bombardier part number.

A Serial Cooling System is utilized on 717 and 787 engines, which offers an efficient cooling of the combustion chamber to prevent the possibilities of detonation.

1, Clamp

To cut or secure non-reusable Oetiker clamps of cooling system hoses, use pliers (P/N 295 000 070).

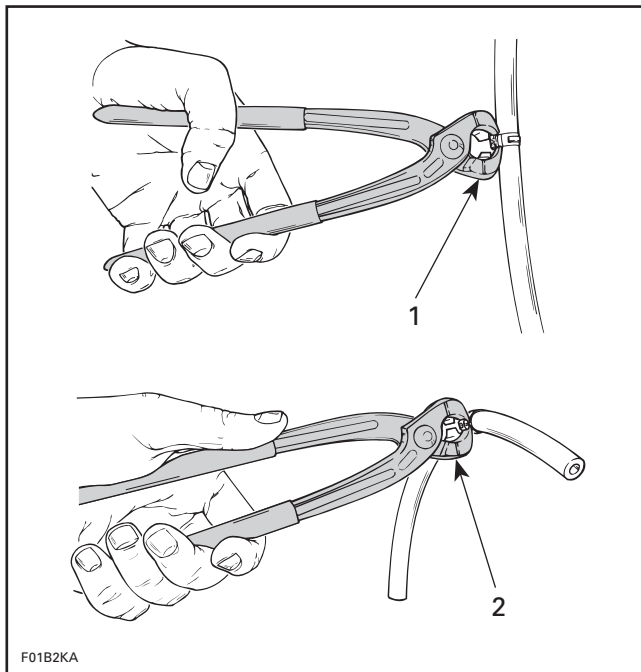

1. Cutting clamp
2. Securing clamp

2, Fitting Spigot

The fitting spigot is used on some models to flush cooling system. Refer to MAINTENANCE 02-02.

3, Elbow Fitting

Water injection used on exhaust system cools the exhaust gases to obtain maximum performance from the tuned pipe. The elbow fitting has a calibrated inside diameter to optimize water flow in tuned pipe.

The water injection also helps in reducing noise level and cools components of the exhaust system.

▼ CAUTION

The elbow fittings are calibrated and can not be interchanged with one of a different size as severe engine damage could result.

The elbow fitting can be identified by using the number stamped onto the fitting or by measuring its inside diameter. Refer to the following illustration and chart.

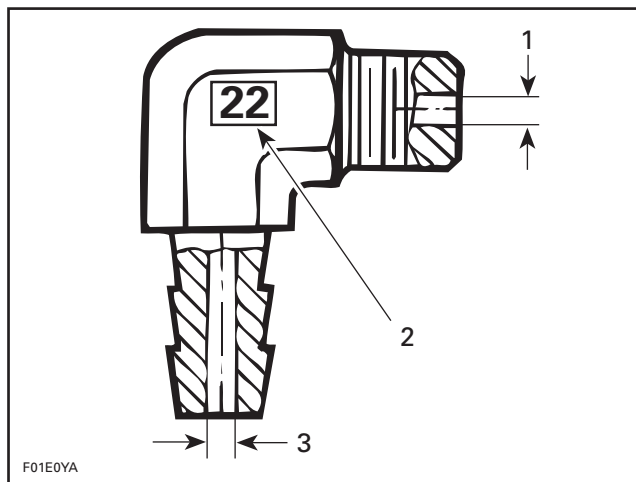

TYPICAL

1. Outlet diameter = 4.6 mm (.181 in)
2. Stamped number
3. Inlet diameter = 5.5 mm (.219 in)

Stamped Number on Fitting	Fitting P/N	Inlet Diameter	Outlet Diameter
22	293 700 022	5.5 mm (.219 in)	4.6 mm (.181 in)
24	293 700 024	5.5 mm (.219 in)	3.5 mm (.139 in)
48	293 710 048	4.0 mm (.157 in)	3.5 mm (.139 in)

4, Water Flow Regulator Valve

A water flow regulator valve has been developed for the 787 engine so that it can produce the maximum horsepower output and yet maintain the necessary diameter of the injection fitting at the tuned pipe head for unobstructed water flow.

The water flow regulator valve is mounted directly onto the muffler.

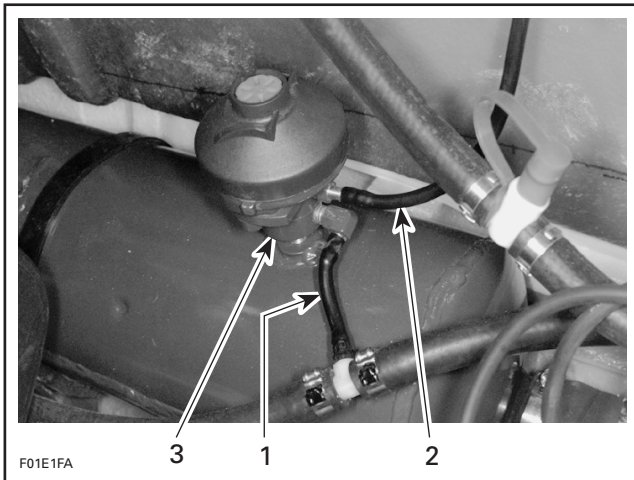

1. Water supply hose of regulator valve
2. Regulated water to injection fitting at tuned pipe head
3. Water injected into the muffler

NOTE: The water injected into the muffler is not regulated by the valve. A calibrated water injection fitting of 3.0 mm (.118 in) inside diameter limits its water flow into the muffler.

The water flow regulator valve has a calibrated spring and a tapered needle which regulate the injected water in the tuned pipe.

▼ CAUTION

Do not change the calibration of the spring, otherwise serious engine damage can occur.

At low speed, water pressure in the supply hose of the regulator valve is not sufficient to overcome the spring of the regulator valve; more water is being delivered to the injection fitting at the tuned pipe.

At higher speed, water pressure increases in the supply hose of the regulator valve and gradually overcomes the return spring of the regulator valve. Less water is being delivered to the injection fitting at the tuned pipe.

Adjustment

The water flow regulator valve has been calibrated at the factory and should not be modified.

NOTE: Water flow regulator valves ordered from the parts channel are also calibrated.

If the maximum engine speed can not be attained or if the engine has poor performance, the water flow regulator valve should be considered in the troubleshooting of the problem.

Mark the location of the red plastic adjustment screw with paint dots for reference purposes.

Fully tighten screw (clockwise) in valve cap.

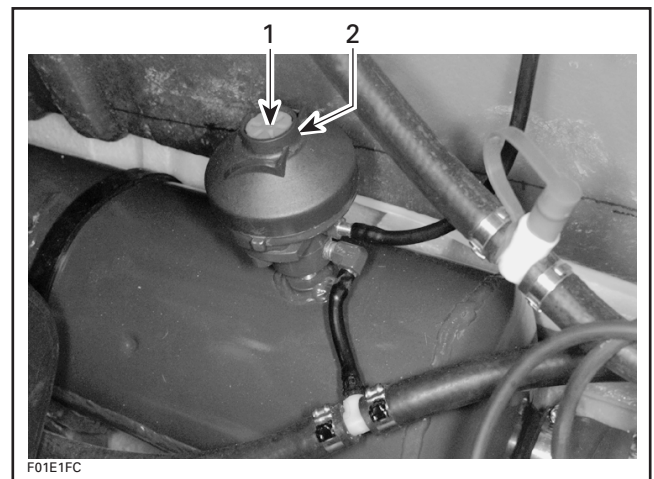

1. Turn this screw
2. Valve cap

Turn the screw 3 turns counterclockwise (loosen). The adjustment is now complete.

NOTE: The water flow regulator valve should deliver 0.4 gallon per minute at maximum engine speed.

Disassembly

5,6, Spring and Cover

Remove the cover of the valve by releasing the spring.

◆ WARNING

Firmly hold cover to valve base. The spring inside the valve is applying a pressure against the cover.

Section 04 COOLING SYSTEM

Sub-Section 02 (COMPONENTS)

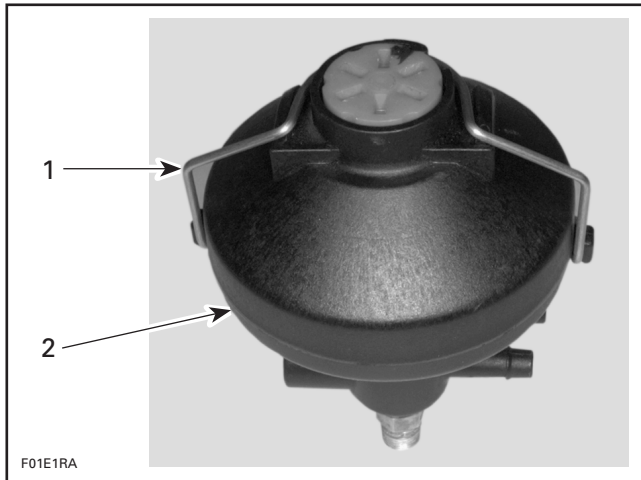

1. Spring
2. Cover

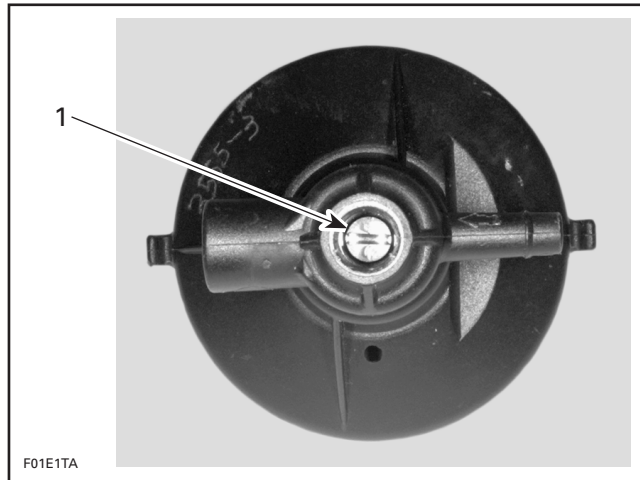

1. Tapered needle

Remove the tapered needle from valve housing.

7, Fitting

Remove fitting from valve housing.

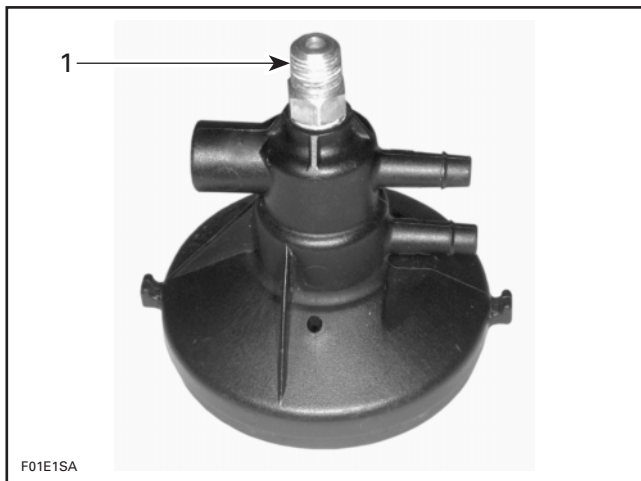

1. Fitting

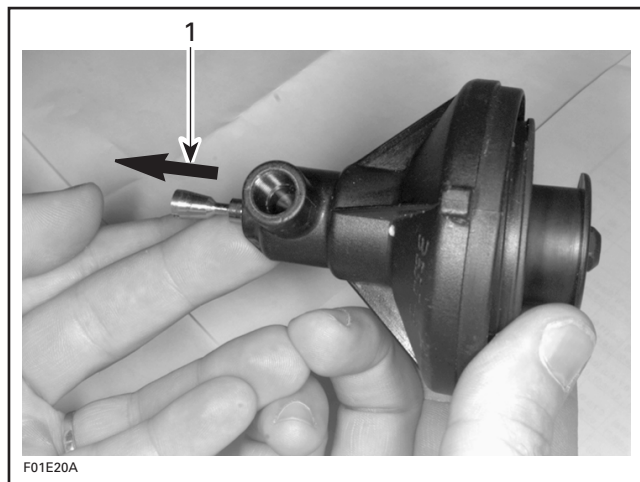

1. Remove tapered needle

8, Tapered Needle

Unscrew the tapered needle.

NOTE: Hold the valve to prevent it from turning.

9,10, Valve and Bellows

Pull the valve slightly. Using pliers, release the clamp which retains the bellows.

Remove valve and bellows.



Loosen clamp to separate valve from bellows.

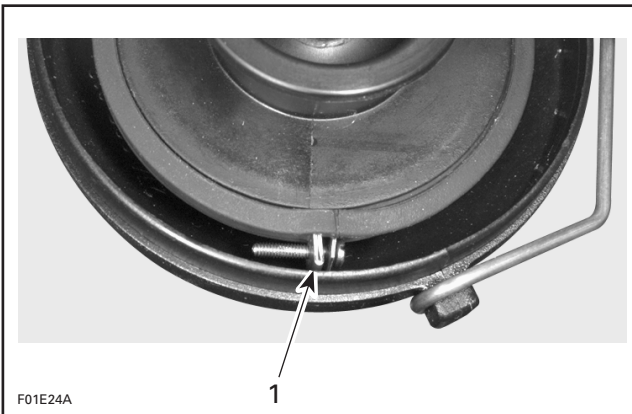

1. Clamp

Inspection

Inspect parts for damage. Verify especially bellows for cracks.

Assembly

Assembly is essentially the reverse of disassembly procedures.

CIRCUIT

GENERAL

The cooling system is equipped with either a fitting spigot or a hose adapter depending upon the model for flushing purposes.

For flushing operation, a coupler hose is available (unnecessary for models with the hose adapter) to connect to the fitting spigot. A garden hose is used to flush the whole system by backwash. For flushing procedure, refer to MAINTENANCE 01-03.

For winterization of cooling system, refer to MAINTENANCE 01-05.

Towing the Watercraft in Water

Special precautions should be taken when towing a Sea-Doo watercraft in water.

Maximum recommended towing speed is 24 km/h (15 MPH).

When towing your watercraft, pinch the water supply hose from the impeller housing to the engine with the Hose Pincher (large) P/N 529 030 400.

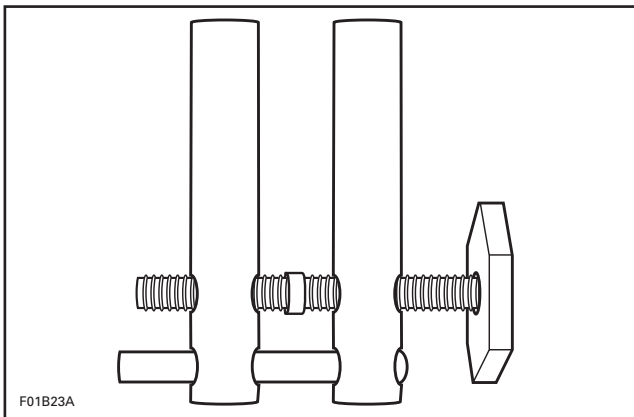

This will prevent the cooling system from filling which may lead to water being injected into and filling the exhaust system. Without the engine running there isn't any exhaust pressure to carry the water out the exhaust outlet.

▼ CAUTION

Failure to do this may result in damage to the engine. If you must tow a stranded watercraft in water and do not have a hose pincher be sure to stay well below the maximum towing speed of 24 km/h (15 MPH).

Snugly install the hose pincher on the water supply hose as shown in the following illustrations.

SP, GS, GSI, GTS and GTI Models

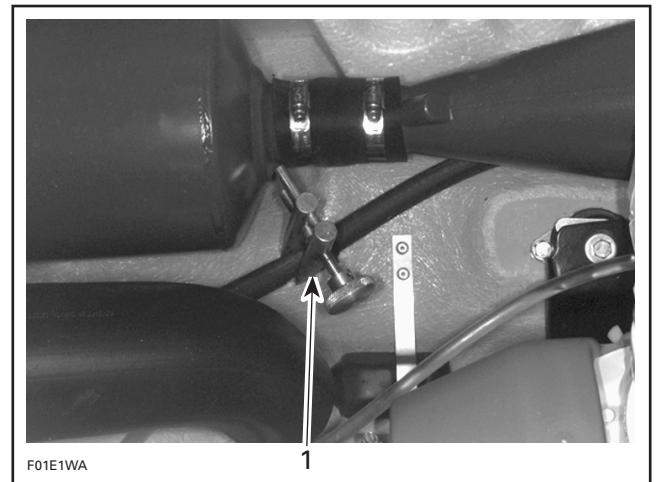

1. Hose pincher

SPX, GSX and GTX Models

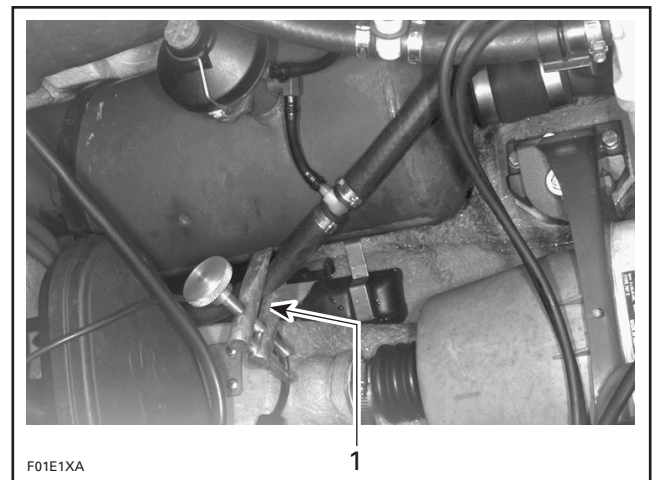

1. Hose pincher

Section 04 COOLING SYSTEM

Sub-Section 03 (CIRCUIT)

XP and HX Models

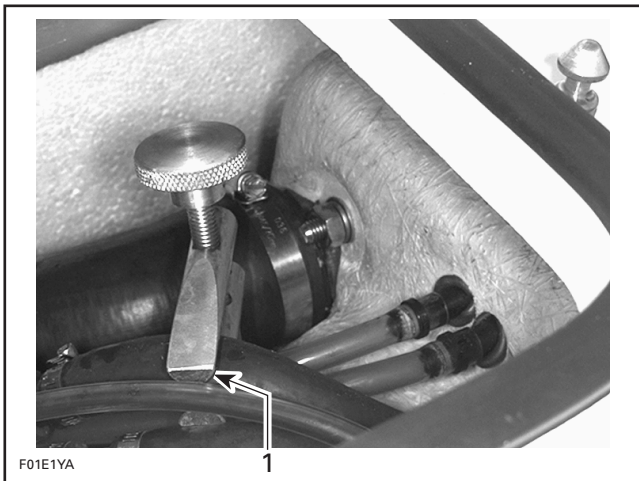

1. Hose pincher

▼ CAUTION

When finished towing the watercraft, the hose pincher must be removed before operating it.

Cooling System Arrangement

The water supply is taken from a pressurized area in the jet pump between the impeller and venturi.

Water enters the cylinder head assembly, cooling the combustion chamber to prevent detonations. Then, water exits cylinder head toward tuned pipe.

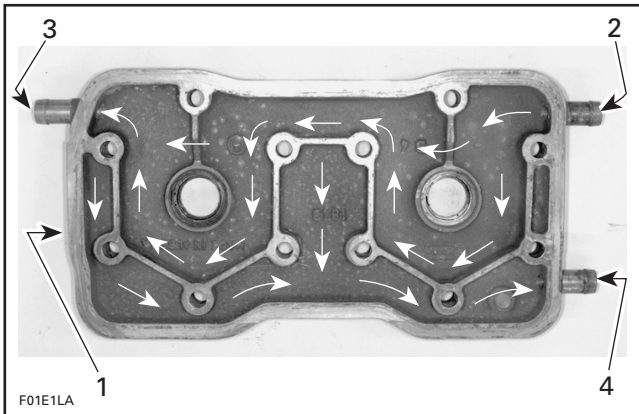

1. Cylinder head cover
2. Fresh water from jet pump
3. Water exiting head assembly to tuned pipe, exhaust manifold and cylinders
4. Water from cylinder water jackets exiting engine

The tuned pipe and exhaust manifold are designed with a double wall to allow water circulation.

Water is pre-heated by the exhaust system before entering the cylinder cooling jackets.

Water enters cylinder cooling jacket through passages located below exhaust ports from tuned pipe.

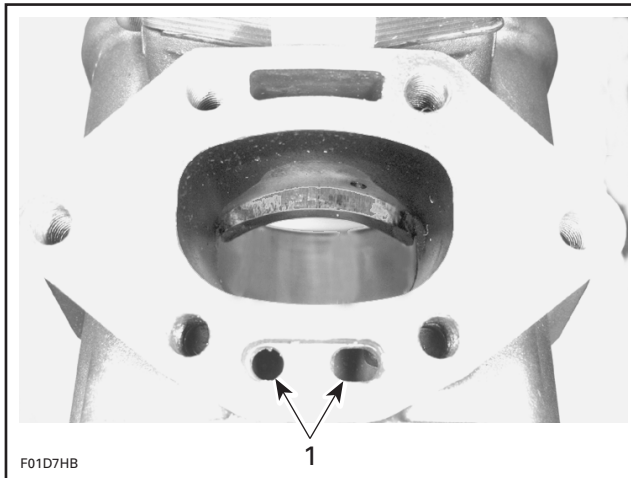

1. Water passages

No water enters crankcase.

When engine is running, water must flow from bleed outlet indicating that water circulates.

▼ CAUTION

When investigating for no water flow in the cooling system, check all elbows and straight fittings as well as all hoses for blockage.

When servicing the hull, always rotate watercraft counterclockwise (seen from the rear). Rotating watercraft clockwise could allow residual water in tuned pipe to enter the engine and cause damage.

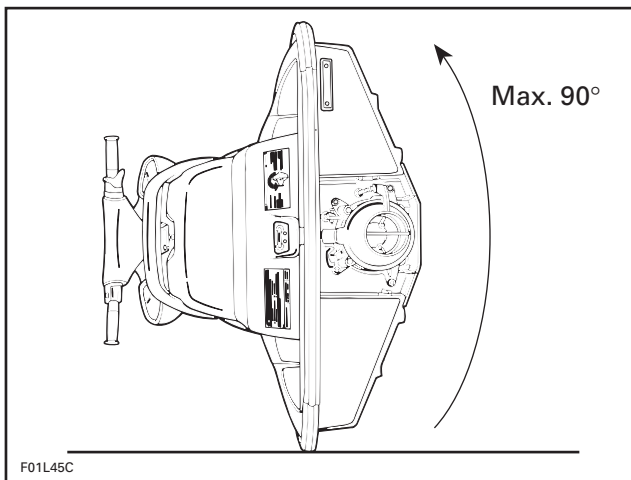

Section 04 COOLING SYSTEM
Sub-Section 03 (CIRCUIT)

For a minimum back pressure in the exhaust, engine water outlet hose is not connected to the exhaust. It has its own outlet at the rear of the hull.

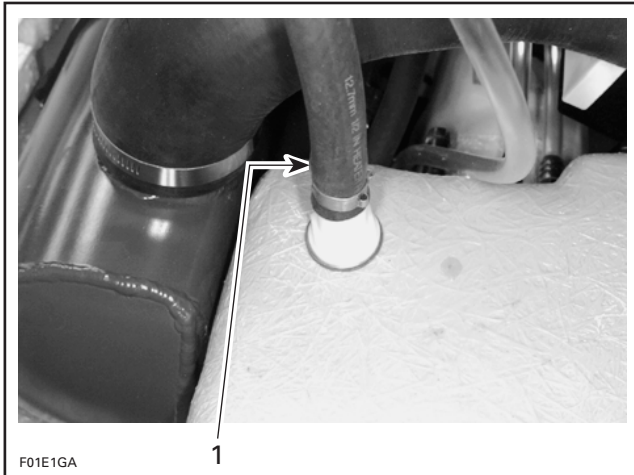

TYPICAL

1. Engine water outlet hose

Draining of the cooling system is accomplished by a drain hose located at the lowest point of the circuit.

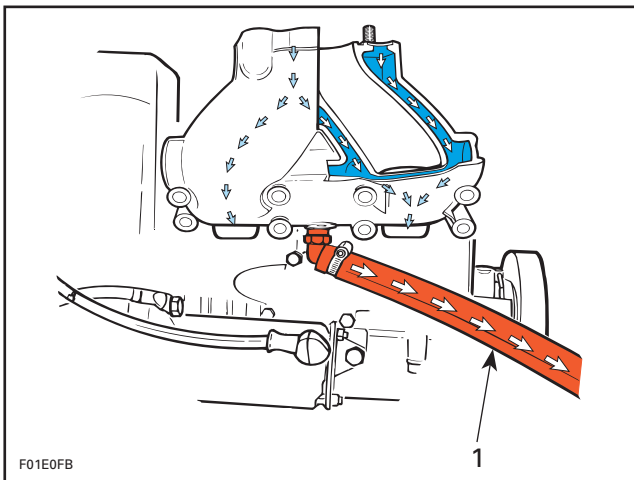

717 ENGINES

1. Drain hose

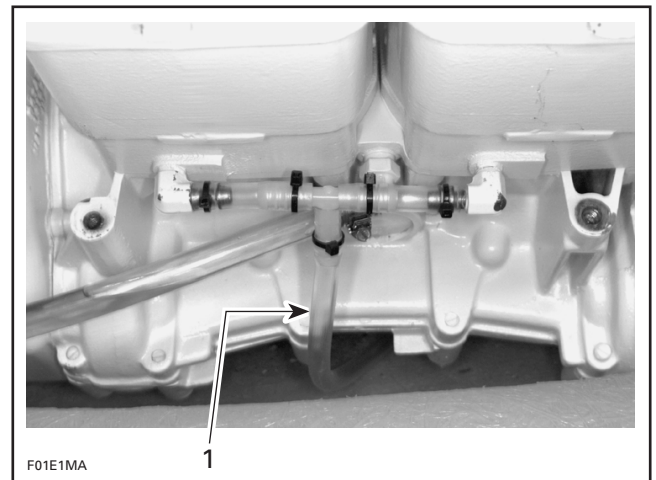

787 ENGINE

1. Drain hose

For a complete view of cooling system arrangement, refer to the next pages for each engine model.

▼ CAUTION

Never modify cooling system arrangement, otherwise serious engine damage could occur.

TECHNICAL DATA

TYPE:

TLCS (Total Loss Cooling System).

COOLANT FLOW:

Pressure build-up at impeller housing (no water pump).

TEMPERATURE CONTROL:

Calibrated outlet fittings (no thermostat).

SYSTEM BLEEDING:

Self-bleed type (hose at uppermost point of circuit).

SYSTEM DRAINING:

Self-drain type (hose at lowest point of circuit).

SYSTEM FLUSHING:

Fitting spigot or hose adapter.

MONITORING BEEPER:

SP, SPX and GTS models: turns on at 95-103°C (203-217°C).

GS, GSI, GSX, GTI, GTX, HX and XP models: turns on at 86-94°C (187-201°C).

Section 04 COOLING SYSTEM

Sub-Section 03 (CIRCUIT)

717 ENGINE COOLING SYSTEM

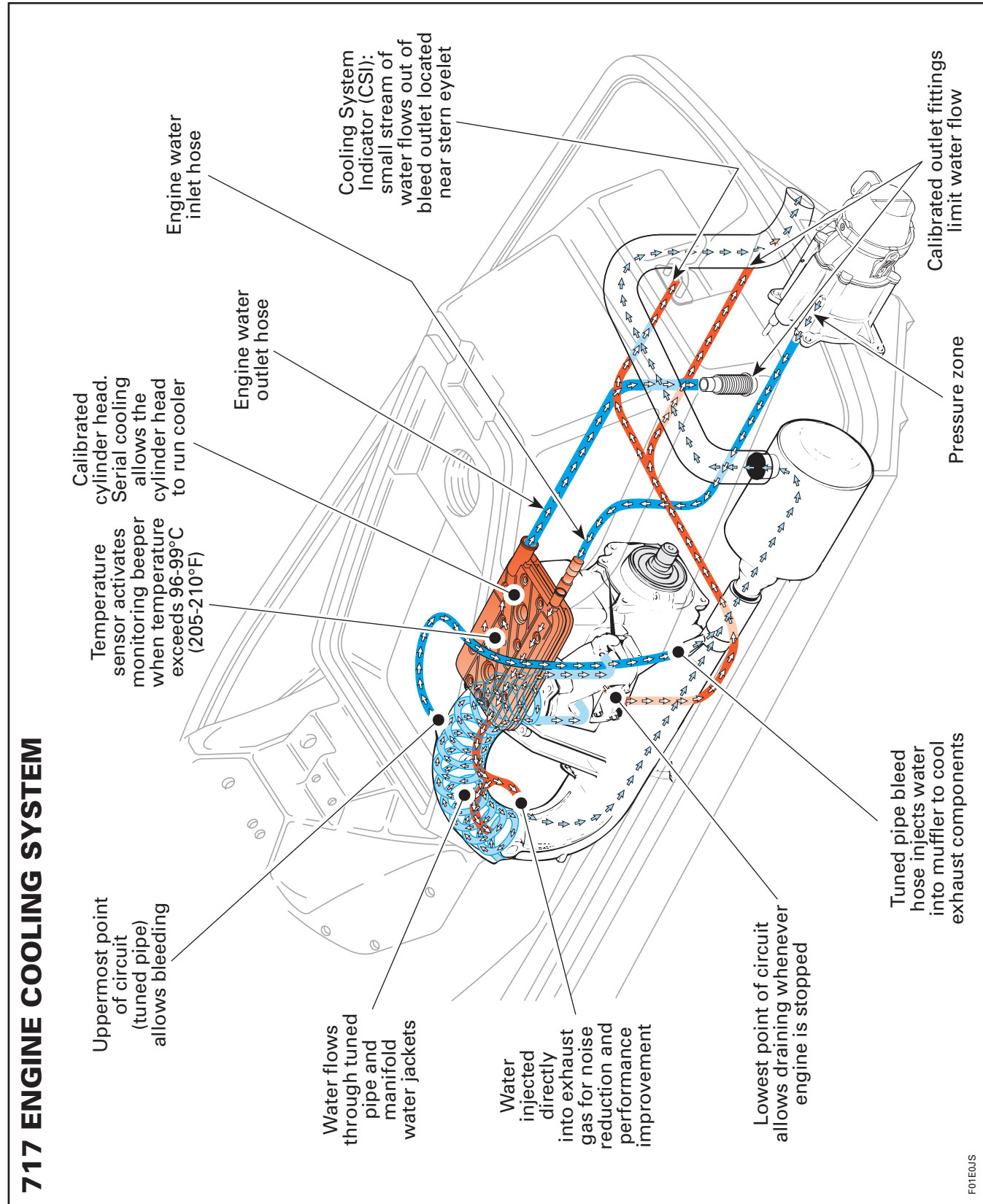

787 ENGINE COOLING SYSTEM

787 ENGINE COOLING SYSTEM

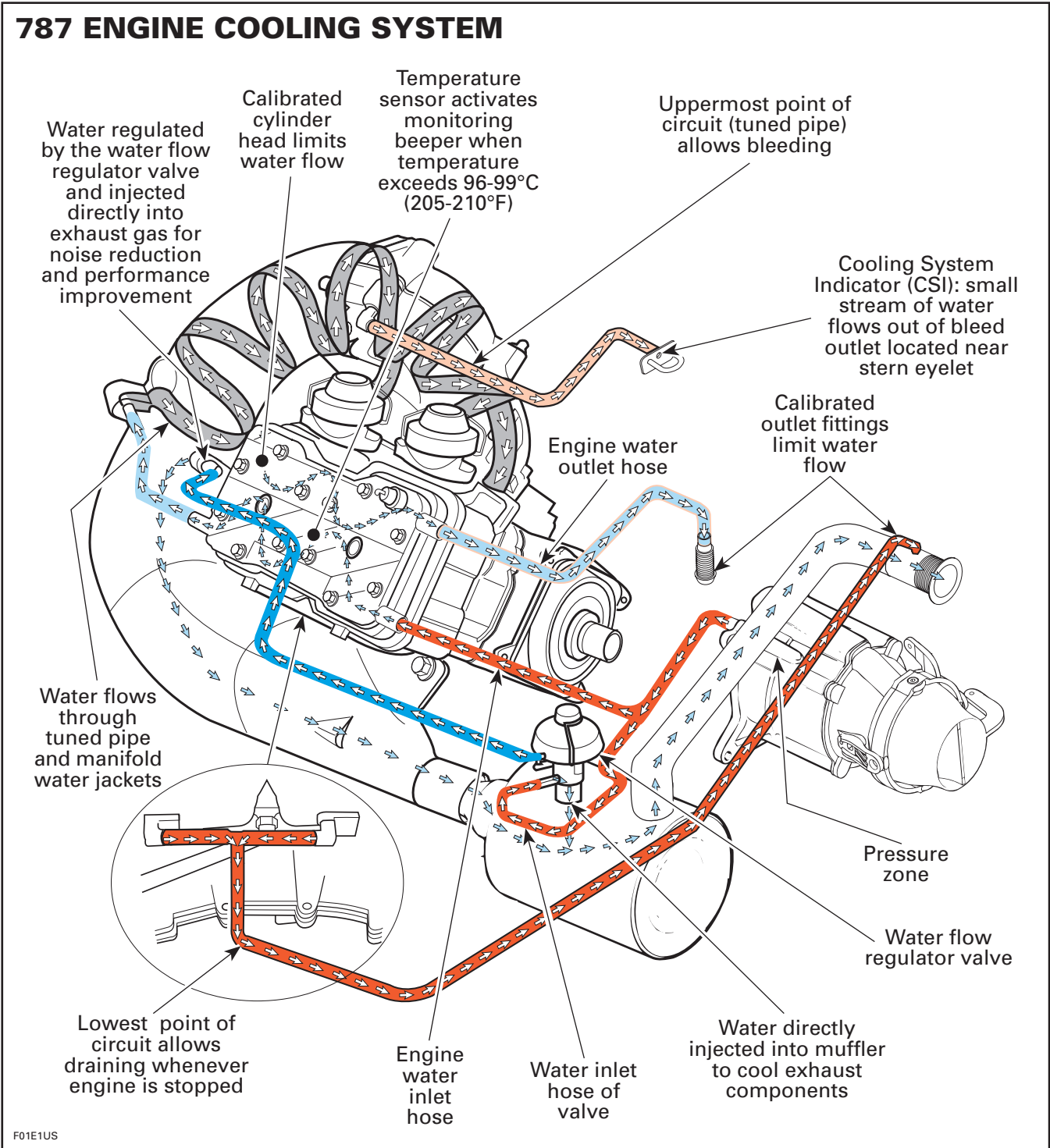

TABLE OF CONTENTS

FUEL CIRCUIT	05-02-1
GENERAL	05-02-6
REMOVAL.....	05-02-7
INSPECTION	05-02-9
ASSEMBLY.....	05-02-10
FUEL SYSTEM PRESSURIZATION	05-02-10

AIR INTAKE	05-03-1
REMOVAL.....	05-03-2
ASSEMBLY.....	05-03-2

CARBURETORS	05-04-1
GENERAL	05-04-3
REMOVAL.....	05-04-3
CLEANING	05-04-4
DISASSEMBLY AND INSPECTION	05-04-4
ASSEMBLY.....	05-04-5
INSTALLATION	05-04-8
ADJUSTMENTS	05-04-9

FUEL CIRCUIT

SP and GTS Models

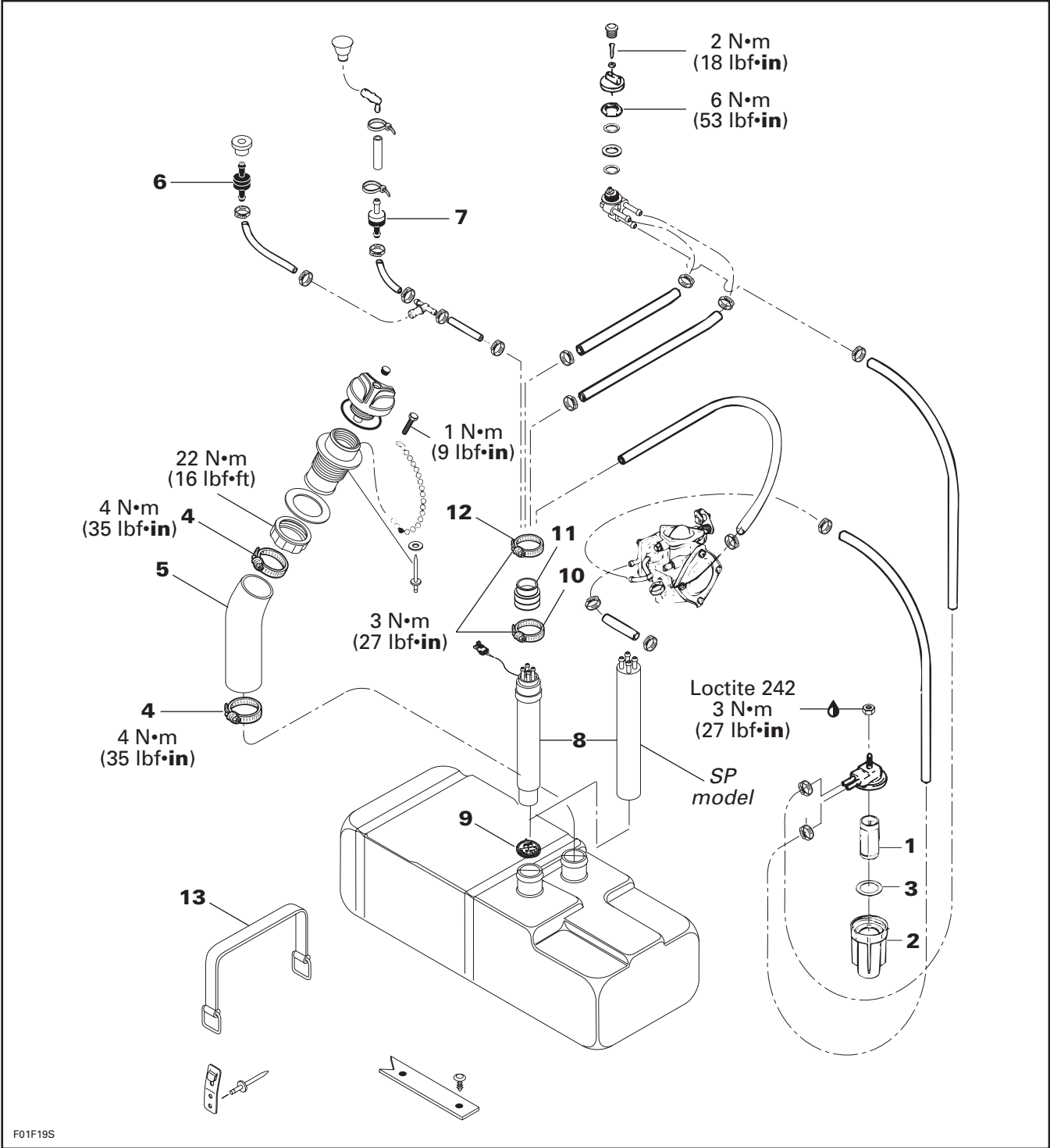

Section 05 FUEL SYSTEM

Sub-Section 02 (FUEL CIRCUIT)

SPX Model

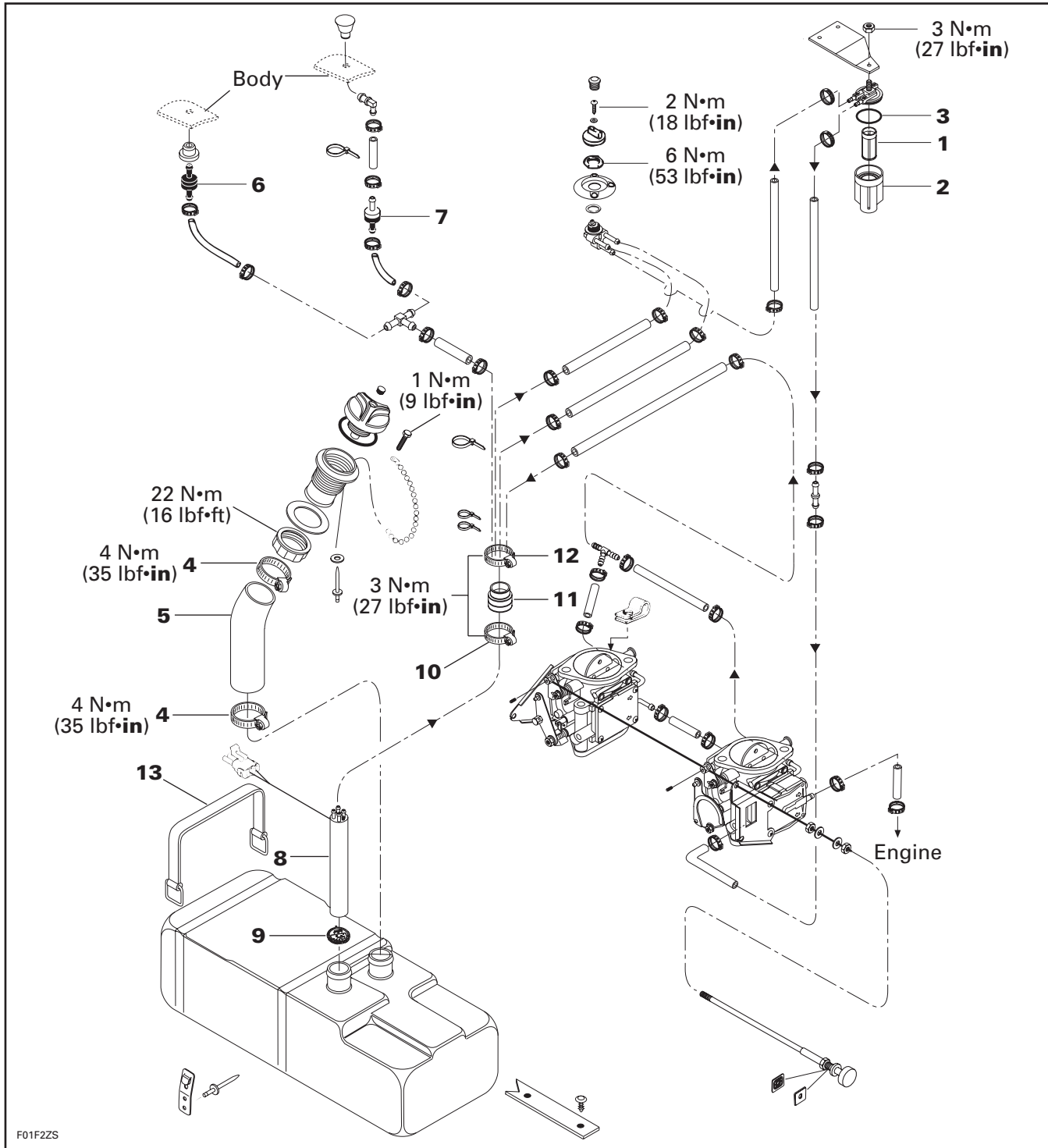

F01F2ZS

Section 05 FUEL SYSTEM
Sub-Section 02 (FUEL CIRCUIT)

GSX and GTX Models

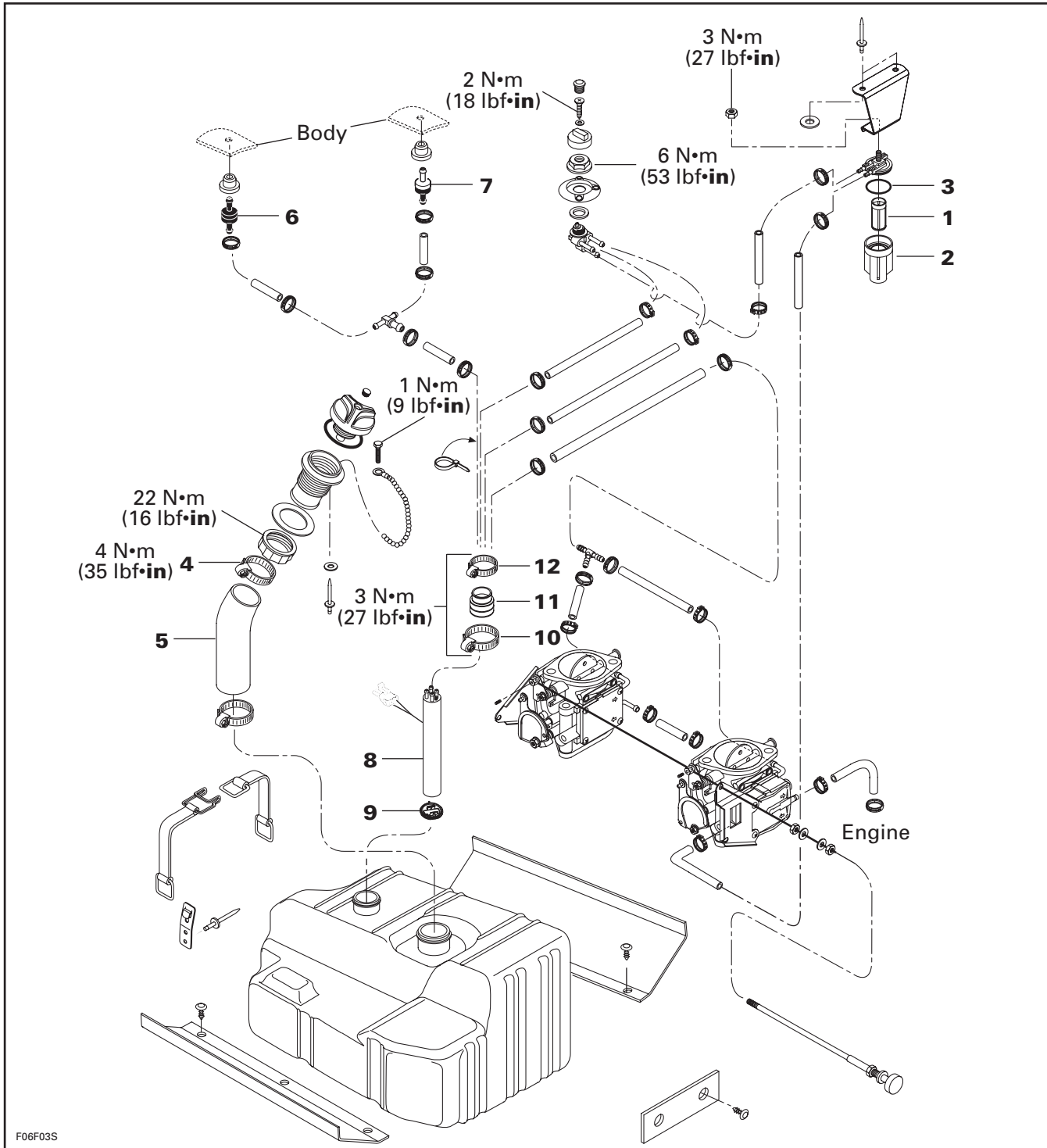

F06F03S

Section 05 FUEL SYSTEM
Sub-Section 02 (FUEL CIRCUIT)

HX and XP Models

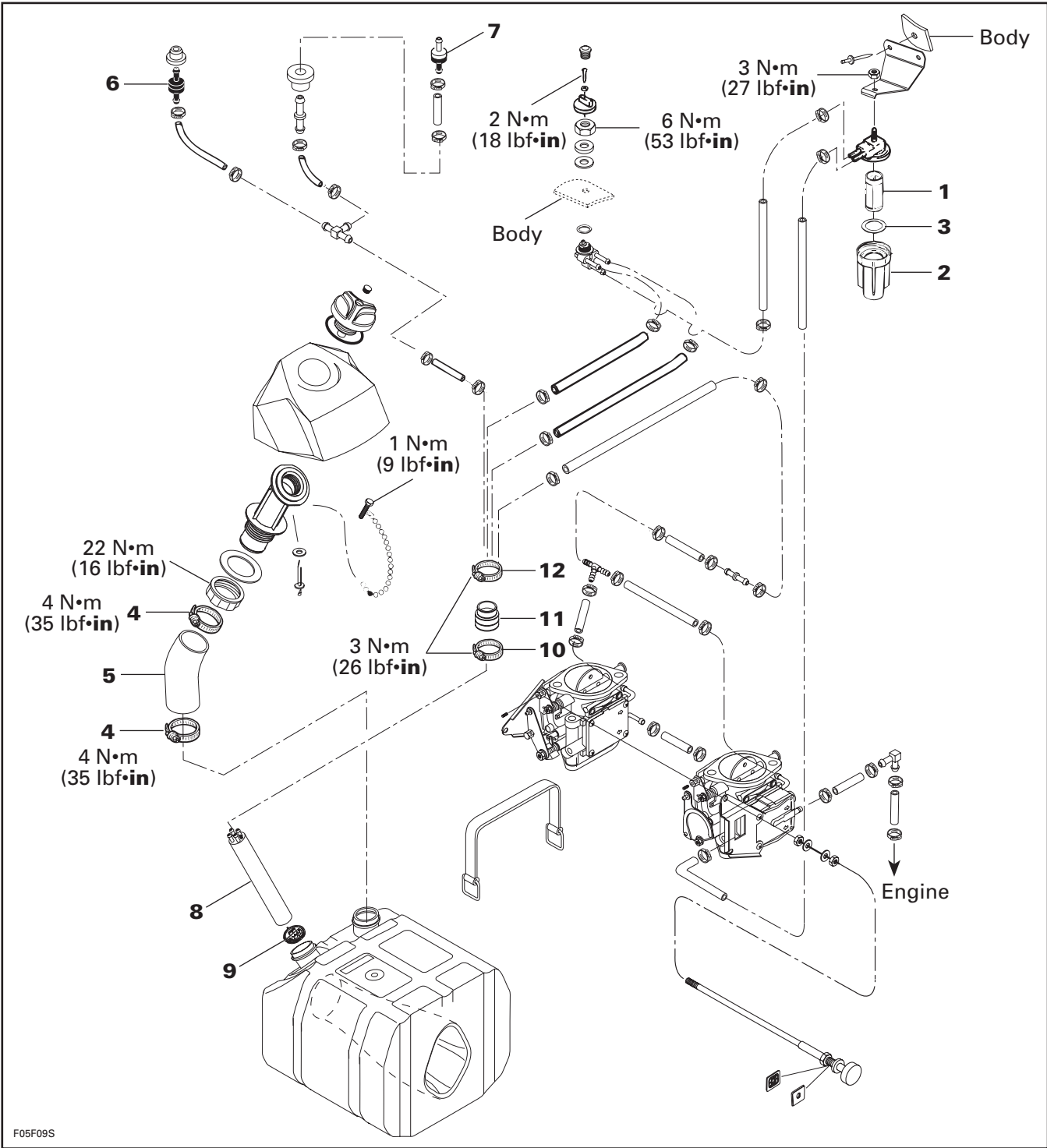

F05F09S

Section 05 FUEL SYSTEM

Sub-Section 02 (FUEL CIRCUIT)

GENERAL

◆ WARNING

Whenever repairing the fuel system, always verify for water infiltration in reservoir.

To open or secure reusable clamps on fuel lines, use pliers (P/N 295 000 054).

To open clamp, place flat side of plier on clamp embossment, squeeze and twist plier.

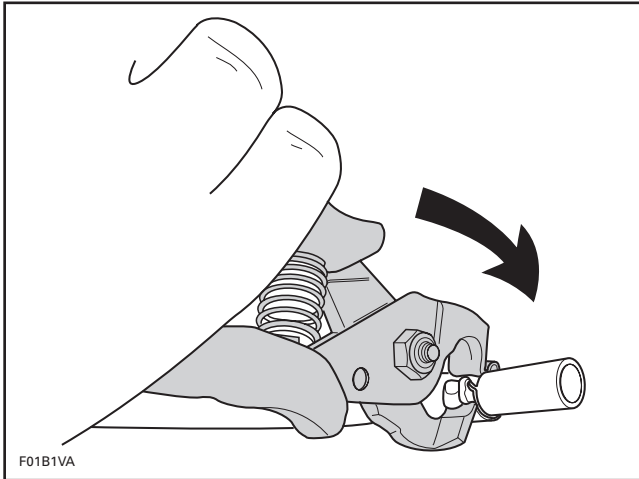

To secure clamp, place notch side of plier on clamp embossment and squeeze plier.

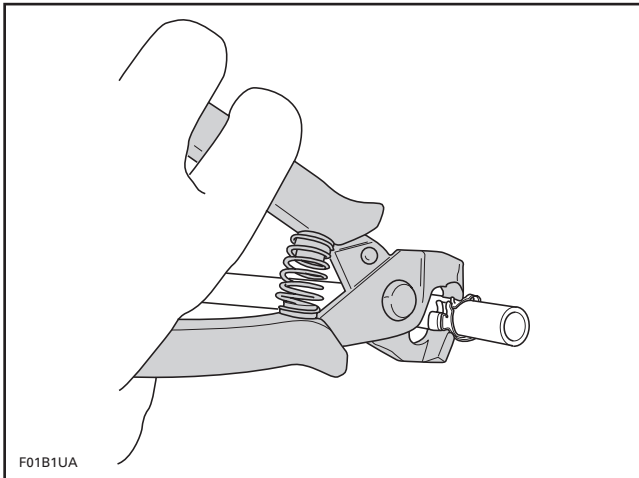

◆ WARNING

Replace any damaged, leaking or deteriorated fuel lines.

To secure or cut Oetiker clamps on fuel lines, use pliers (P/N 295 000 070).

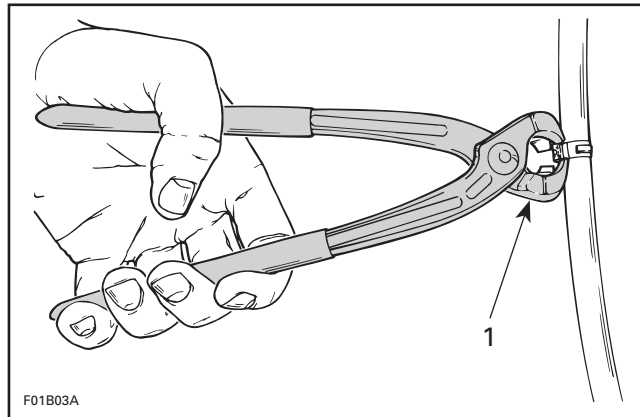

1. Cutting clamp

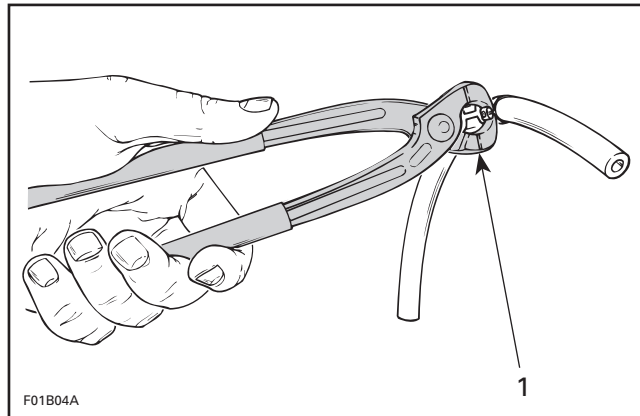

1. Securing clamp

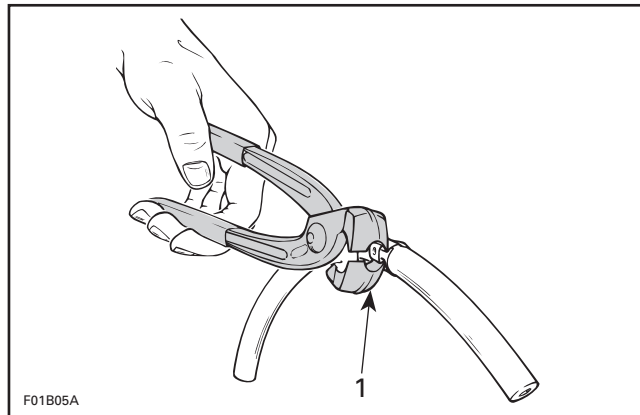

1. Securing clamp in limited access

When replacing fuel lines on SEA-DOO watercraft, be sure to use "B1" hoses as available from Bombardier parts department. This will ensure continued proper and safe operation.

◆ WARNING

Use of improper fuel lines could compromise fuel system integrity.

REMOVAL

1, Fuel Filter

All Models Except HX and XP

Open storage compartment cover.
Remove basket.

HX and XP Models

Open engine cover.

GTS Model

Press on vent tube upper part to enable to withdraw tube from body.

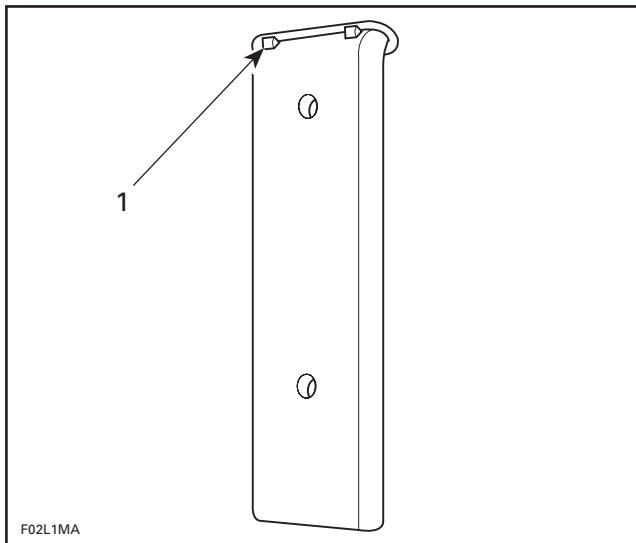

TYPICAL

1. Press on vent tube

All Models

Turn the fuel valve to OFF position.

◆ WARNING

The engine must not be running and fuel valve must be set to OFF position. Gasoline is flammable and explosive under certain conditions. Always work in a well ventilated area.

Unscrew fuel filler cap to remove any fuel pressure in system.

Unscrew the fuel filter bowl **no. 2** counterclockwise then pull toward the bottom.

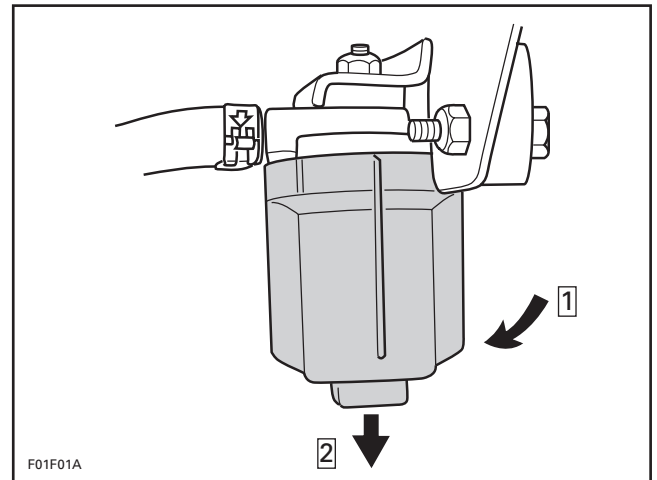

TYPICAL

Step **1** : Loosen counterclockwise

Step **2** : Pull

Pull fuel filter **no. 1** toward the bottom.

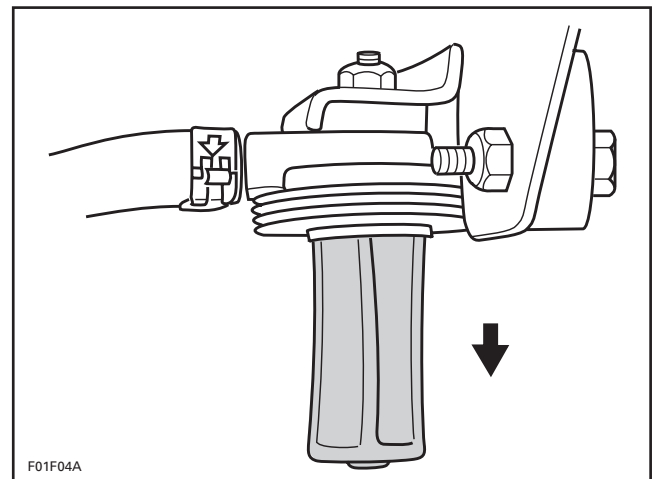

TYPICAL

8, Fuel Baffle Pick Up

NOTE: The baffle pick up has an integrated fuel sensor on models which have a fuel gauge.

Section 05 FUEL SYSTEM

Sub-Section 02 (FUEL CIRCUIT)

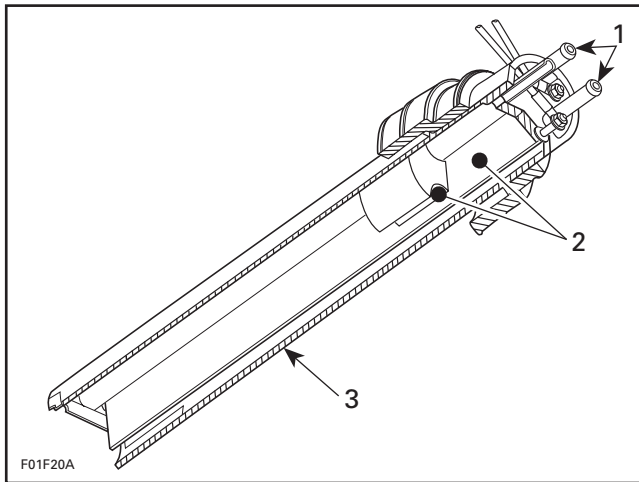

1. Pick up tube
2. Fuel sensor
3. Baffle pick up

Disconnect BLACK negative cable, then RED positive cable of battery.

◆ WARNING

Always disconnect battery cables exactly in the specified order, BLACK negative cable first.

Empty fuel tank.

◆ WARNING

Fuel is flammable and explosive under certain conditions. Always work in a well ventilated area. Always wipe off any fuel spillage from the watercraft.

SP, SPX and GTS Models

Open storage compartment cover.

Remove storage basket from watercraft.

On GTS model, remove vent tube. Refer to **fuel filter removal** procedure in this sub-section.

Disconnect filler neck hose **no. 5** from fuel tank.

Remove retaining straps **no. 13** from fuel tank and move tank forward.

GS, GSI and GSX Models

Open storage compartment cover.

Remove storage basket from watercraft.

Remove steering assembly. Refer to STEERING SYSTEM 09-04.

GTI and GTX Models

Remove glove box.

HX Model

Pull down left vent tube.

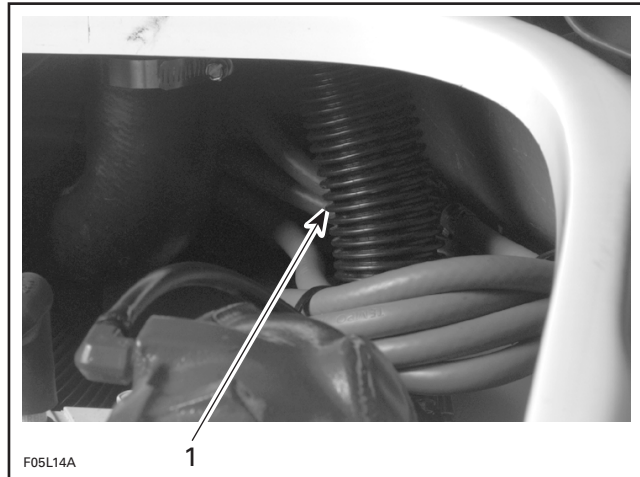

1. Vent tube

Cut tie rap retaining fuel hoses to tie-mount.

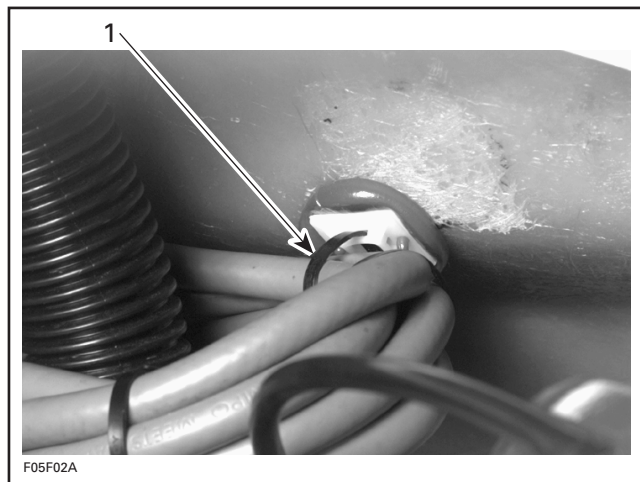

1. Cut tie rap

XP Model

Tilt seat. Refer to HULL/BODY 11-02.

Remove access plug on body.

All Models

Remove hoses from baffle pick up and disconnect wiring harness of fuel sensor (if applicable).

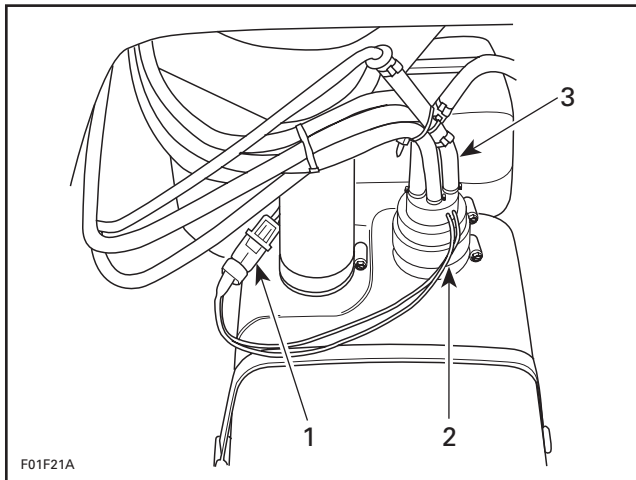

TYPICAL

- 1. Wiring harness
- 2. Baffle pick up adapter
- 3. Fuel hoses

Loosen lower clamp **no. 10** of baffle pick up adapter and pull out baffle **no. 8** from fuel tank.

Remove upper clamp **no. 12** from adapter **no. 11** and slide adapter from baffle.

Push inward on the 3 clips at the base of the baffle in order to remove the filter. Pry base off using a small slotted screwdriver (if necessary).

INSPECTION

1, Fuel Filter

Inspect fuel filter condition. Carefully use low pressure compressed air to clean fuel filter. Replace filter if permanently clogged or damaged.

2, Fuel Filter Bowl

Check filter bowl for water contamination.

3, Gasket

Inspect gasket condition. Make sure gasket is well positioned into the filter bowl **no. 2**.

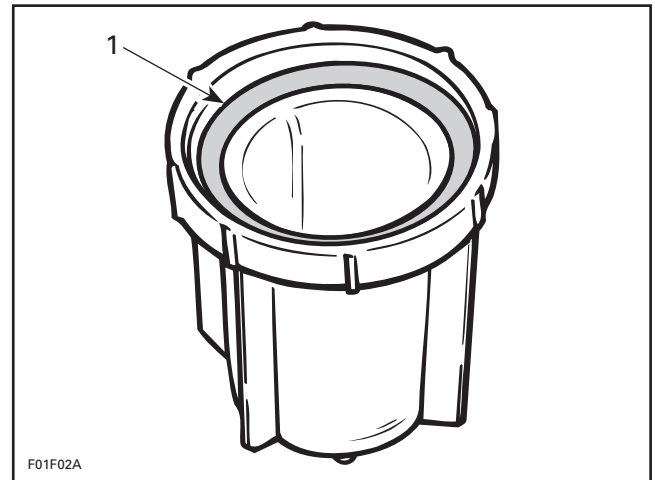

- 1. Gasket in bowl

◆ WARNING

Ensure that there is no leakage from the fuel filter.

5, Filler Neck Hose

Verify fuel filler neck hose for damage. Always ensure that clamps **no. 4** are well positioned and tightened. Torque clamps to 4 N•m (35 lbf•in).

6, Pressure Relief Valve

This valve will eliminate fuel spillage when the watercraft is upside down. If pressure is built up in fuel system the valve should open at 10 kPa (1.5 PSI) to release the pressure.

◆ WARNING

If pressure relief valve is stuck, the pressure in fuel system will build up and it may cause fuel leakage in engine compartment.

NOTE: It is a one-way valve with an arrow to indicate the air flow.

7, Check Valve

Black side of the one-way check valve is the valve outlet. It allows air to get in reservoir.

9, Baffle Pick Up Filter

Inspect filter **no. 9** of baffle pick up. Clean or replace as necessary.

Section 05 FUEL SYSTEM

Sub-Section 02 (FUEL CIRCUIT)

ASSEMBLY

Assembly is essentially the reverse of disassembly procedures. However pay particular attention to the following.

8, Baffle Pick Up

Slide adapter no. 11 onto baffle pick up no. 8 until it stops on rib. Install clamp no. 12.

Install baffle pick up no. 8 into fuel tank and push it until it sits on fuel tank neck. Install clamp no. 10 and torque both clamps to 3 N•m (27 lbf•in).

HX Model Only

Make sure to align notch of baffle pick up no. 8 with the mark on the fuel tank.

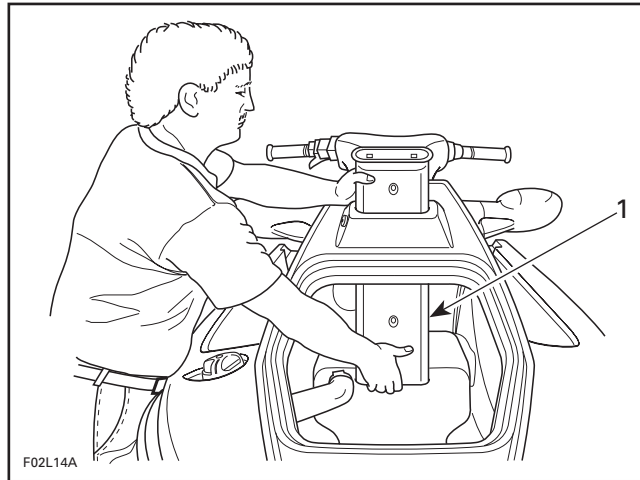

1. Install vent tube

FUEL SYSTEM PRESSURIZATION

◆ WARNING

Whenever doing any type of repair on watercraft or if any components of the fuel system are disconnected, a pressure test must be done before starting engine. Ensure to verify fuel line ends for damage. Always cut damaged end before reinstallation.

Pressure Test

Proceed as follows:

- Fill up fuel tank.
- Disconnect air inlet hose of fuel tank from body.
- Install a hose pincher (P/N 295 000 076) on fuel tank vent hose.

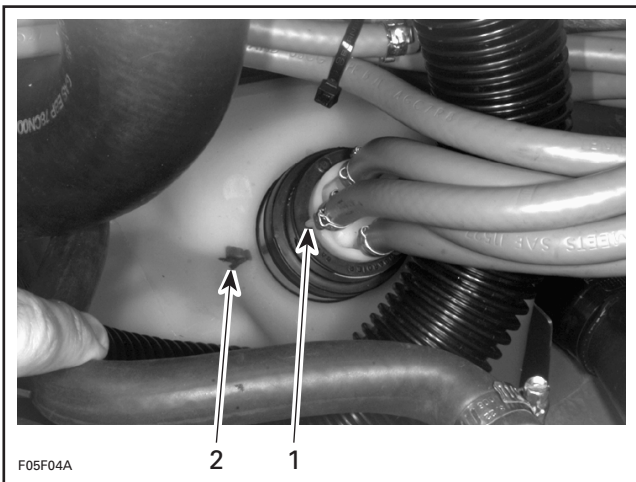

1. Baffle pick up notch
2. Fuel tank mark

GTS Model Only

Insert vent tube in body and clip it in place.

◆ WARNING

Vent tube must be in place to provide proper bilge ventilation.

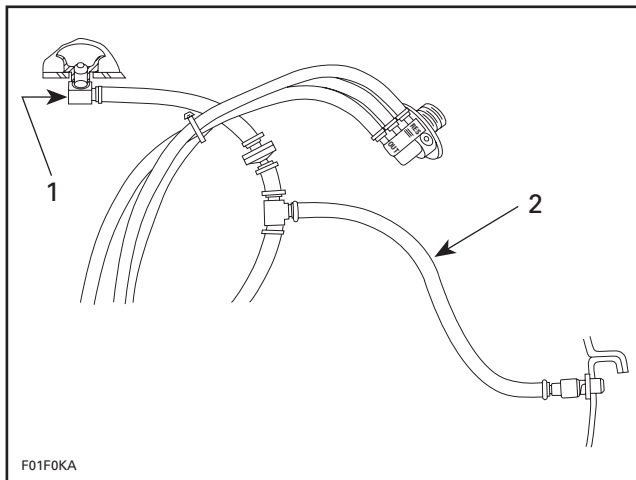

TYPICAL

1. Disconnect air inlet hose
2. Install a hose pincher to vent hose

- Connect pump gauge tester (P/N 295 021 800) to air inlet hose.

NOTE: This pump is included in the ENGINE LEAK TESTER KIT (P/N 295 500 352).

- Turn fuel valve to OFF position and pressurize fuel system to 34 kPa (5 PSI). If no leaks are found, turn fuel valve to ON position and pressurize once more.
- If pressure is not maintained locate leak and repair/replace component leaking. To ease leak search spray a solution of soapy water on components, bubbles will indicate leak location.

NOTE: The system must maintain a pressure of 34 kPa (5 PSI) during 10 minutes. Never pressurize over 34 kPa (5 PSI).

Reconnect air inlet hose of fuel tank to body.

◆ WARNING

If any leak is found, do not start the engine and wipe off any fuel leakage. Do not use electric powered tools on watercraft unless system has passed pressure test.

NOTE: Before removing the hose pincher, block with your finger the outlet fitting to feel if air is coming out when removing hose pincher. This will indicate that pressure relief valve and the outlet fitting are not blocked.

Remove hose pincher from fuel tank vent hose.

AIR INTAKE

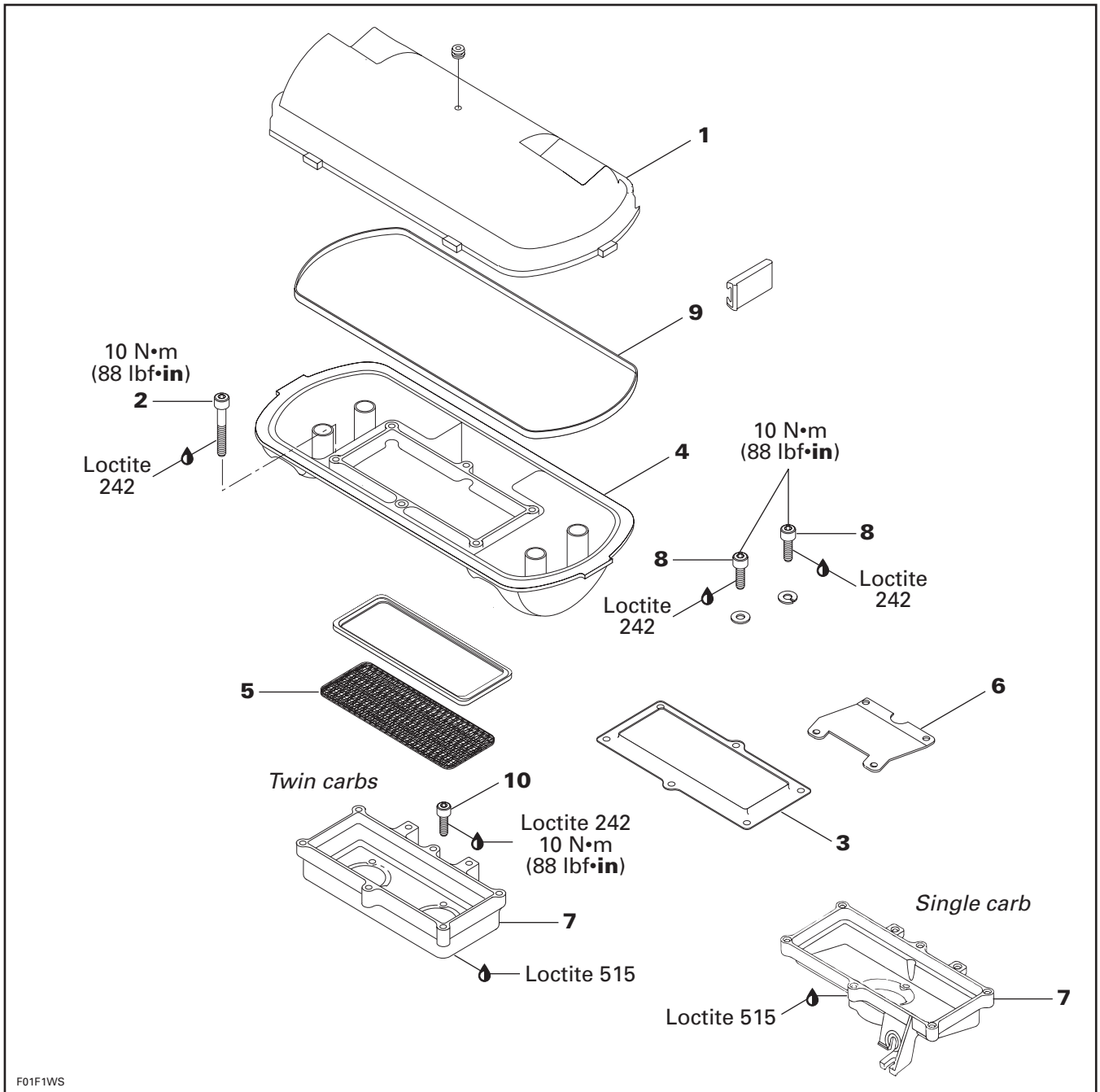

Section 05 FUEL SYSTEM

Sub-Section 03 (AIR INTAKE)

REMOVAL

1, Air Intake Silencer Cover

Unlock retaining slides holding air intake silencer cover and remove cover.

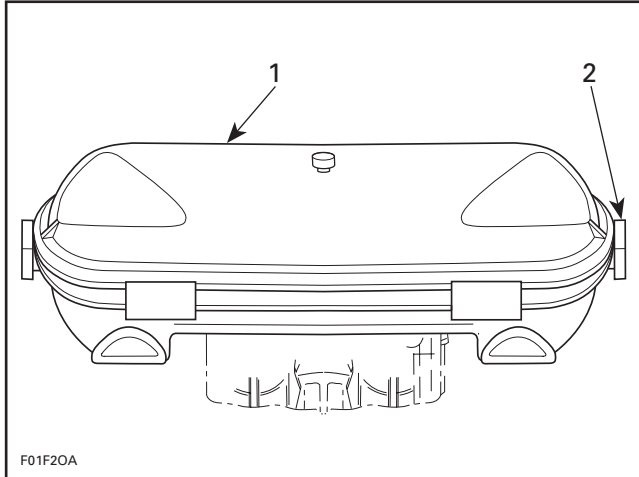

TYPICAL

1. Air intake silencer cover
2. Unlock

4, Air Intake Silencer Base

Remove screws no. 2 of retaining plate no. 3.

Pull out retaining plate no. 3 and air intake silencer base no. 4.

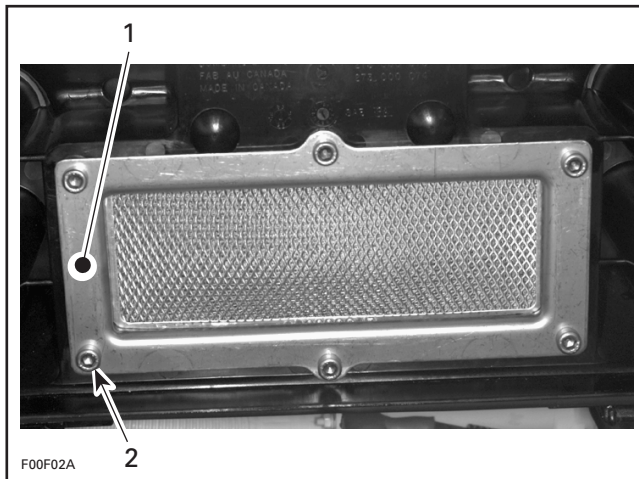

1. Retaining plate
2. Remove screws

7, Flame Arrester Base

Remove flame arrester no. 5.

Remove screws no. 8 retaining support no. 6 of flame arrester base to the cylinder head cover (717 engines) or to the exhaust manifold (787 engine).

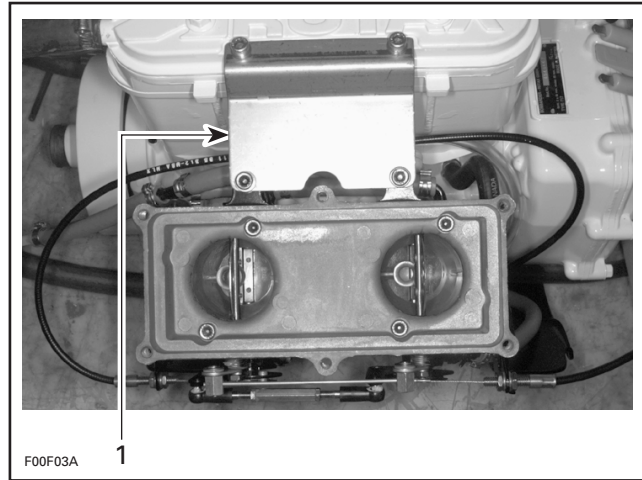

1. Remove support

Remove screws no. 10 from flame arrester base then withdraw base.

NOTE: On single Mikuni carburetor models, remove choke and throttle cables from flame arrester base.

ASSEMBLY

Assembly is essentially the reverse of removal procedures. However pay particular attention to the following.

▼ CAUTION

Do not modify air intake system, otherwise calibration will be affected.

7, Flame Arrester Base

Apply Loctite 515 on mating surfaces of flame arrester base.

Apply Loctite 242 (blue) on screws no. 10 and torque to 10 N•m (88 lbf•in).

5, Flame Arrester

Inspect condition of flame arrester. Replace or clean as necessary.

◆ WARNING

Do not operate watercraft without flame arrester.

787 Engine

Position the flame arrester with its embossment toward TOP.

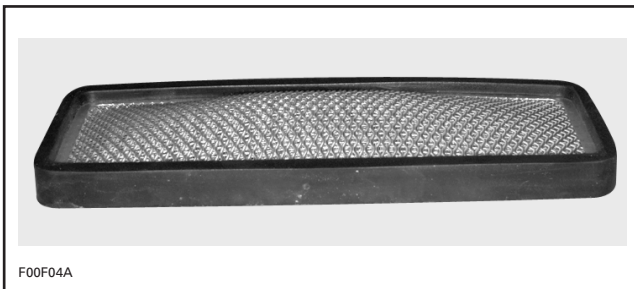

9, Gasket

Inspect condition of gasket. Make sure to properly installed gasket.

CARBURETORS

Mikuni BN-38

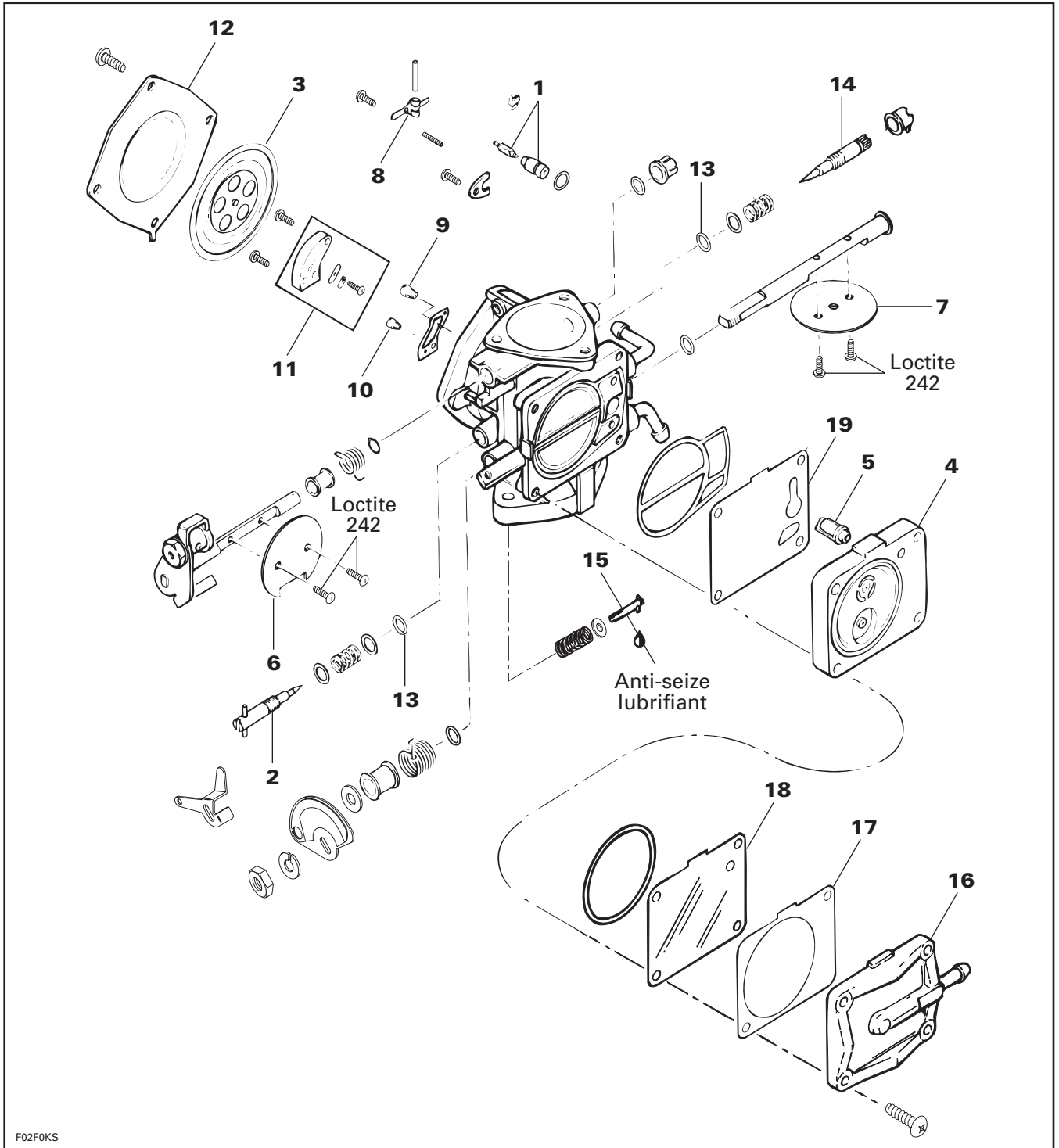

F02F0KS

Section 05 FUEL SYSTEM
Sub-Section 04 (CARBURETORS)

Mikuni BN-38I, BN-40I

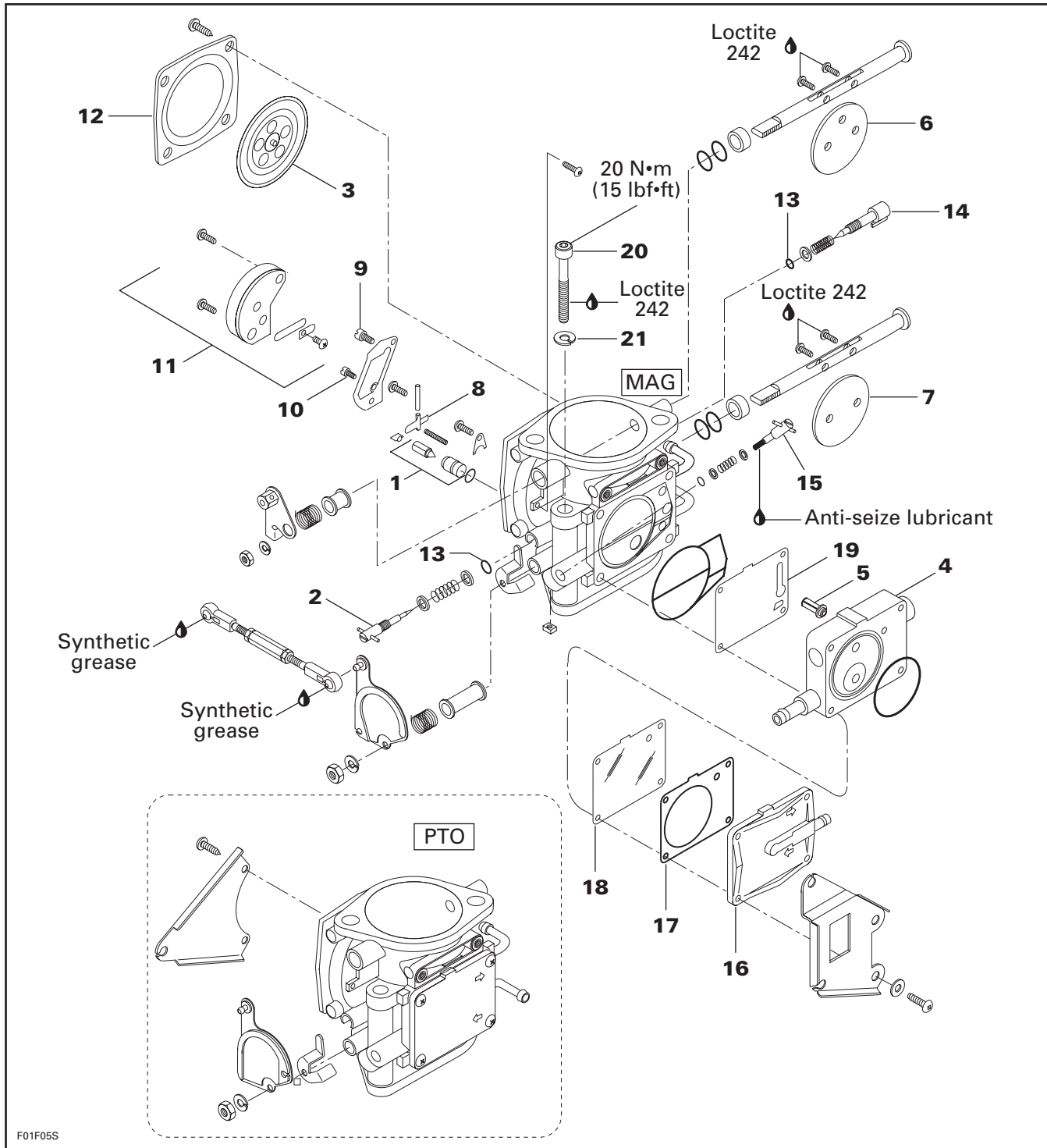

F01F05S

GENERAL

The following illustration shows which part of the carburetor begins to function at different throttle plate openings.

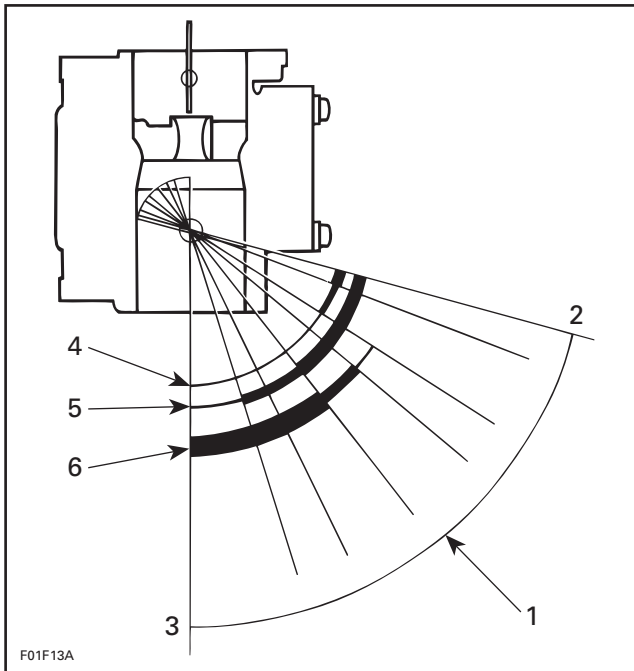

VIEW FROM AIR INTAKE OPENING

1. Throttle plate openings
2. Throttle plate closed
3. Throttle plate wide opened
4. Low-speed screw
5. Pilot jet
6. Main jet and high-speed screw

REMOVAL

To remove carburetor(s) from engine, proceed as follows:

Remove air vent tube support (SP, SPX, GS, GSI and GSX models).

Remove air intake silencer. Refer to FUEL SYSTEM 05-03.

Turn fuel valve to OFF position.

Disconnect pulse line.

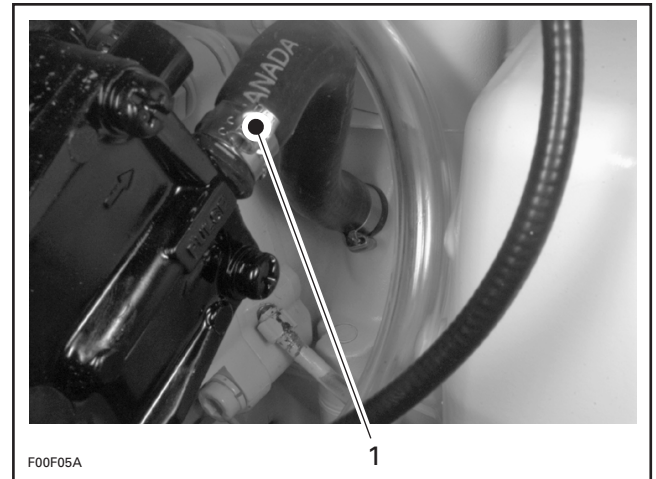

TYPICAL

1. Pulse line

Disconnect fuel supply line from fuel pump.

Disconnect fuel return line.

Disconnect oil injection pump cable, throttle cable and choke cable.

BN-38 Carburetor

Remove 4 bolts and lock washers from rotary valve cover then move carburetors and rotary valve on top of engine.

NOTE: When removing rotary valve cover, pay attention that the rotary valve will stay in place, otherwise it must be timed.

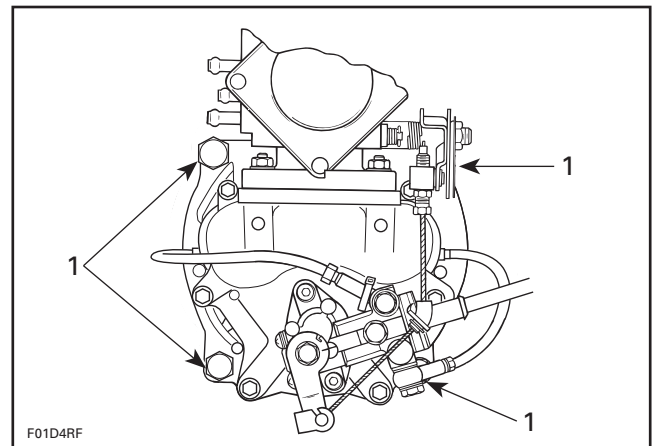

1. Rotary valve cover bolt

Remove carburetor from intake manifold.

BN-38I and BN-40I Carburetors

Remove screws **no. 20** and lock washers **no. 21** retaining carburetors.

Section 05 FUEL SYSTEM

Sub-Section 04 (CARBURETORS)

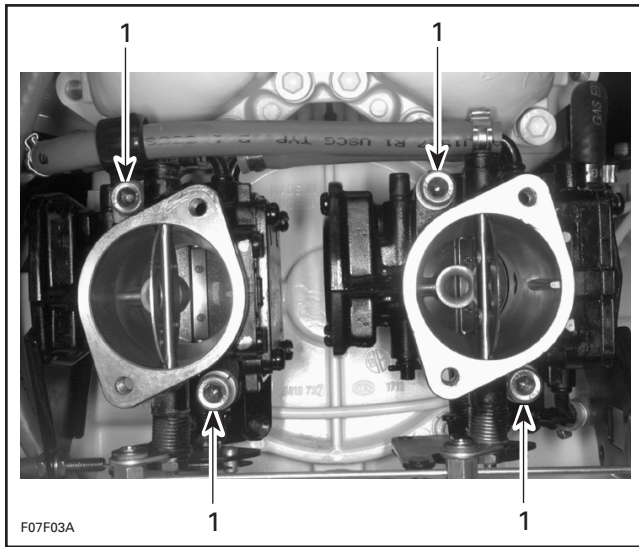

1. Screw

Remove carburetors.

CLEANING

The entire carburetor should be cleaned with a general solvent and dried with compressed air before disassembly.

▼ CAUTION

Be careful at carburetor cleaning not to remove paint. Paint removal will cause carburetor to rust very rapidly. Repaint if necessary.

Carburetor body and jets should be cleaned with a carburetor cleaner. Follow manufacturer's instructions.

◆ WARNING

Solvent with a low flash point such as gasoline, naphtha, benzol, etc., should not be used as they are flammable and explosive.

▼ CAUTION

Heavy duty carburetor cleaner may be harmful to the rubber parts, O-rings, etc. Therefore, it is recommended to remove these parts prior to cleaning.

Inspect O-rings, diaphragms and gaskets.

DISASSEMBLY AND INSPECTION

Inspect parts for corrosion damage (shaft, throttle plate, spring, screw, check valve housing, etc.).

1, Needle Valve

Inspect needle valve tip for a grooved condition. If worn, needle and seat must be replaced as a matched set.

2, Low Speed Screw

Check tip for a grooved condition. Replace if necessary.

3, Diaphragm

PUMP DIAPHRAGM LEAK TEST

Using a suitable pump gauge tester, perform the following test proceeding as follows:

- Install pump gauge tester (P/N 295 000 114) on pulse nipple.
- Pump tester until it reaches 28 kPa (4 PSI).

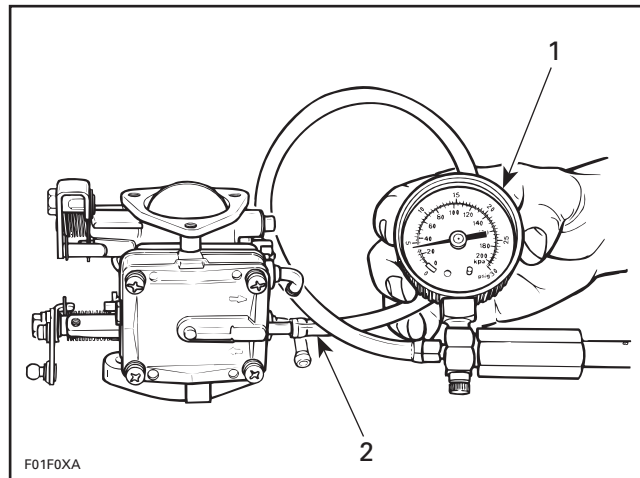

TYPICAL

1. Pump gauge tester
2. Install on pulse nipple

Diaphragm must stand pressure for 10 seconds. If pressure drops, replace diaphragm.

4, Pump Body

Check fuel pump valve operation as follows:

Connect a clean plastic tubing to the inlet nipple and alternately apply pressure and vacuum with the mouth. The inlet valve should release with pressure and hold under vacuum.

◆ WARNING

Some fuel may be present in fuel pump. Be careful not to swallow fuel when under vacuum.

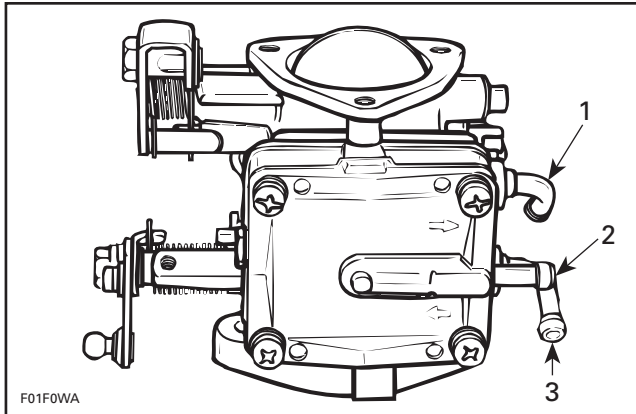

TYPICAL

- 1. Fuel outlet nipple
- 2. Pulse nipple
- 3. Inlet nipple

Repeat the same procedure at the outlet nipple. This time the outlet valve should hold with pressure and release under vacuum.

Inspect valves. The pumping area should be free of holes, tears or imperfections. Replace as needed.

5, Filter

To verify filter condition proceed as follows:

Remove pump cover no. 16, gasket no. 17, diaphragm no. 18 and then pump body no. 4 and diaphragm no. 19.

Remove filter from carburetor body then clean filter and blow carefully with compressed air (low pressure).

Replace filter if damaged.

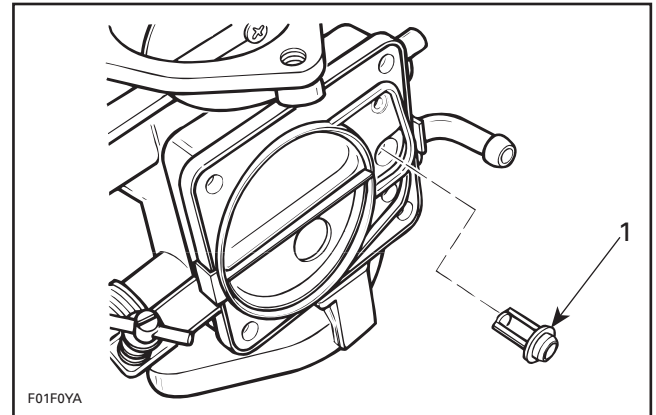

TYPICAL

- 1. Filter

ASSEMBLY

When assembling pump, ensure to properly position components together. Refer to previous illustrations if necessary.

6,7, Choke Plate and Throttle Plate

When installing plate onto shaft, close plate so that it centers into carburetor bore. Firmly tighten screws.

▼ CAUTION

Always apply Loctite 242 (blue) on screw threads prior to installing screws.

8, Needle Valve Lever

Rounded end of needle valve lever must be flush with surrounding metering chamber floor and not with body assembly. Place the end of a ruler over lever to check adjustment.

Section 05 FUEL SYSTEM

Sub-Section 04 (CARBURETORS)

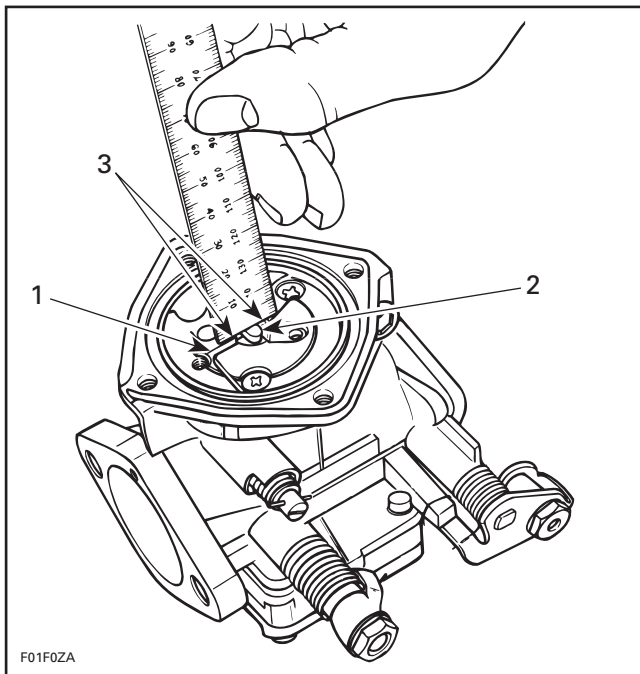

1. Metering chamber floor
2. Lever end
3. Flush

To adjust, bend lever very slightly to change its height.

▼ CAUTION

When adjusting lever, do not pry it so that it applies pressure on needle. This could damage valve seat/needle.

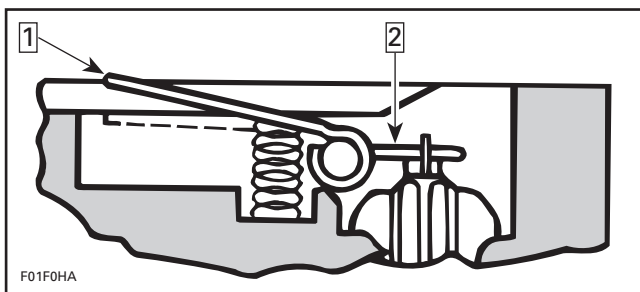

HIGH LEVER

- Step 1 : Depress here
- Step 2 : Push tab down

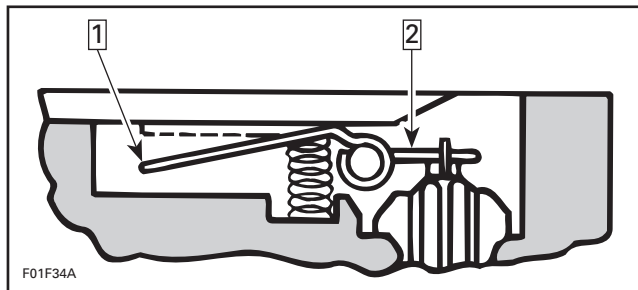

LOW LEVER

- Step 1 : Depress here
- Step 2 : Pry up here

POP-OFF PRESSURE TEST

Proceed as follows:

- Install pump gauge tester on carburetor fuel inlet nipple.
- Obstruct fuel return nipple with a finger.
- Pump tester until inlet release pressure is reached (seen by a sudden pressure drop).

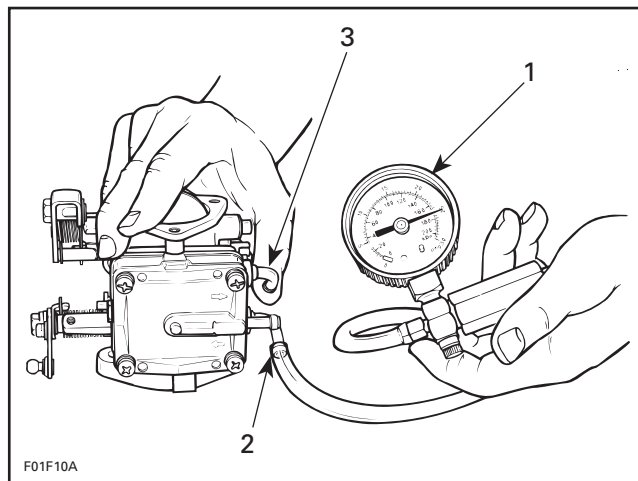

TYPICAL

1. Pump gauge tester
2. Install on inlet nipple
3. Obstruct outlet nipple

Refer to the following table for pop-off pressures (PSI), from needle valve size and arm spring combinations:

Valve Seat Diameter (mm)	Arm Spring Load (g)			
	51	65	80	115
1.2	29 ± 8	38 ± 10	48 ± 12	76 ± 15
1.5	17 ± 5	27 ± 8	33 ± 10	42 ± 12
2.0	11 ± 4	16 ± 5	21 ± 7	29 ± 8

NOTE: Pressure test should be performed three times to obtain a valid reading.

If pop-off pressure is not within specification, check control lever adjustment. Replace spring as necessary.

▼ CAUTION

Do not stretch or cut spring.

LEAK TEST

Needle valve must stand a pressure of 69 kPa (10 PSI) for 30 seconds. Otherwise, hold carburetor upside down, pour oil over needle valve and apply pressure.

Check for bubbles. If they come from seat or O-ring, bubbles will exit around seat. Retighten as necessary.

If it still leaks remove needle and seat and replace O-ring.

If bubbles come from needle, replace needle and seat.

9,10, Main Jet and Pilot Jet

Pilot jet and main jet are replaceable. Different jet sizes are available to suit temperature and altitude conditions. Always inspect spark plug tip condition when dealing with pilot jet and main jet. Spark plug tip condition gives a good indication of carburetor mixture setting.

▼ CAUTION

Adjustments vary with temperature and altitude. Always observe spark plug condition for proper jetting.

NOTE: To have access to pilot jet or main jet, check valve housing must be removed.

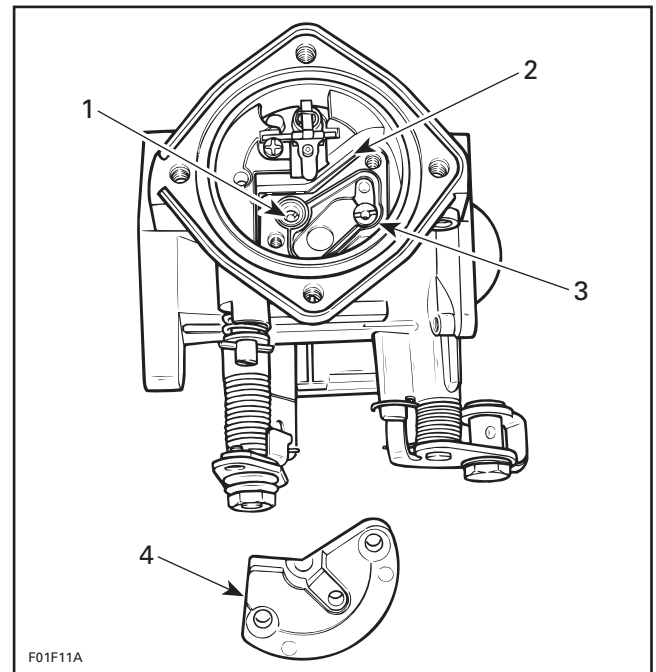

TYPICAL

- 1. Pilot jet
- 2. Gasket
- 3. Main jet
- 4. Check valve housing removed

11, Check Valve Assembly

The check valve is needed if a back pressure occurs into carburetor. It will prevent fuel from flowing back into carburetor lower portion.

Inspect check valve, it should be free of holes, tears or imperfections. Replace as needed.

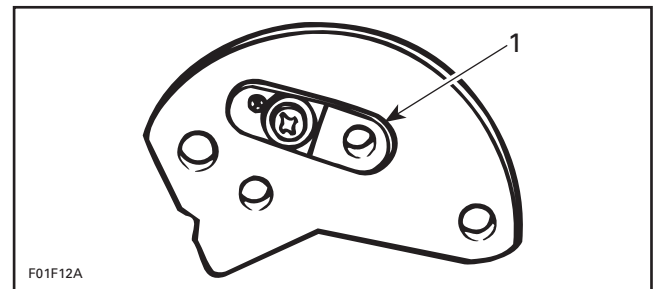

- 1. Check valve

NOTE: Prior to check valve assembly installation, remember to set gasket.

3,12, Diaphragm and Cover

Install diaphragm with its integrated O-ring into carburetor groove. Make sure that the tab of cover is inserted into carburetor notch.

Section 05 FUEL SYSTEM

Sub-Section 04 (CARBURETORS)

13, O-ring

When installing O-rings of low speed and high speed screws, apply some BOMBARDIER LUBE (P/N 293 600 016) to prevent sticking.

INSTALLATION

At installation, pay attention to the following:

Install carburetor(s) with gasket(s) to intake manifold (rotary valve cover for the 787 engine).

BN-38 Carburetor

Install lock washers and apply Loctite 242 (blue) on threads then torque nuts to 25 N•m (18 lbf•ft).

BN-38I and BN-40I Carburetors

Apply Loctite 242 (blue) on screws **no. 20**. Then, install screws **no. 20** with lock washers **no. 21** and torque to 20 N•m (15 lbf•ft).

Twin Carburetor Synchronization

With idle speed screw not touching throttle lever stopper on MAG carburetor, both throttle plates are in closed position.

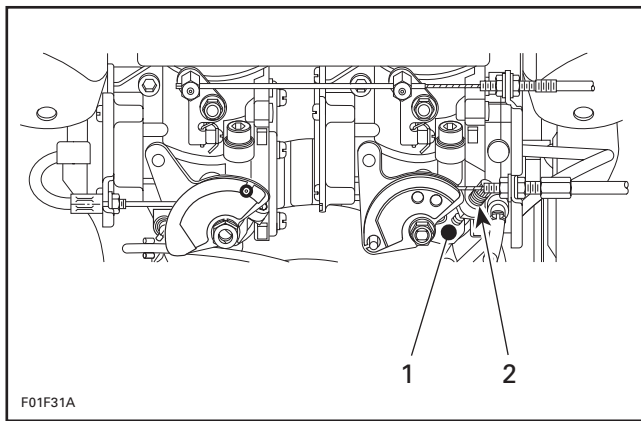

1. Stopper
2. Idle speed screw

Loosen jam nuts on carburetor linkage and adjust linkage with adjustment nut.

Make sure threads length is the same on each side of linkage and flat surfaces of both ends are parallel with each other.

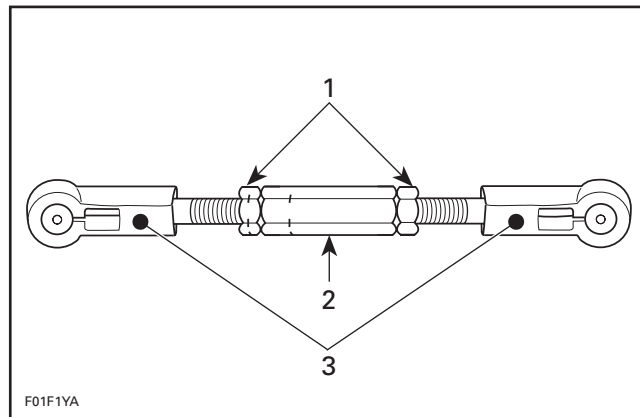

1. Jam nuts
2. Adjustment nut
3. Flat surfaces

Tighten jam nuts and torque to 3 N•m (27 lbf•in).

NOTE: Grease carburetor linkage at both ends with synthetic grease (P/N 293 550 010).

Connect linkage between both carburetor levers. Ensure both throttle plates are still in closed position.

NOTE: The linkage installation is done with the marks located near PTO carburetor throttle lever to ease adjustment if to be performed in the watercraft.

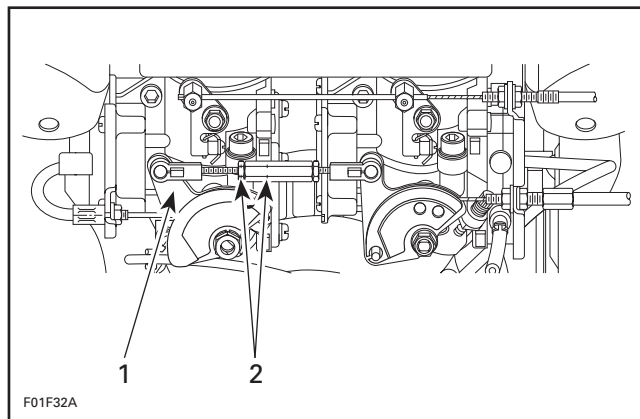

1. Throttle lever PTO side
2. Marks

▼ CAUTION

Throttle plates must open simultaneously, otherwise this will cause engine to vibrate and/or back fire.

Fuel Lines and Hose Clamps

If fuel line ends are damaged, cut damaged end before reinstallation.

Properly install clamps.

◆ WARNING

Make sure there is no leak in fuel system.

For fuel system pressurization, refer to FUEL SYSTEM 05-02.

ADJUSTMENTS

Throttle Cable

Lubricate cable with BOMBARDIER LUBE lubricant.

Throttle lever must reach handlebar grip without causing strain to cable or carburetor cable bracket.

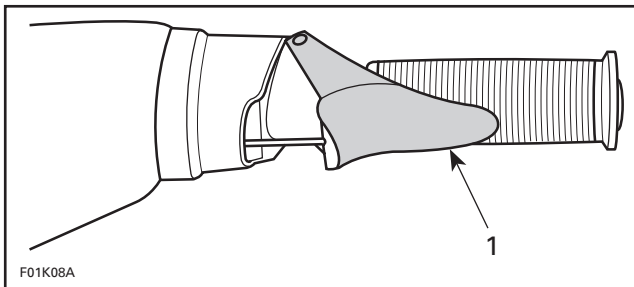

1. Must touch handlebar grip

Ensure carburetor throttle plate is fully open at full throttle position. At this position throttle lever stopper is almost in contact (0.5 mm (1/64 in)) with carburetor body.

▼ CAUTION

Improper cable adjustment will cause strain on cable and/or damage cable bracket or throttle lever at handlebar.

To adjust, loosen jam nut then turn adjustment nut as necessary.

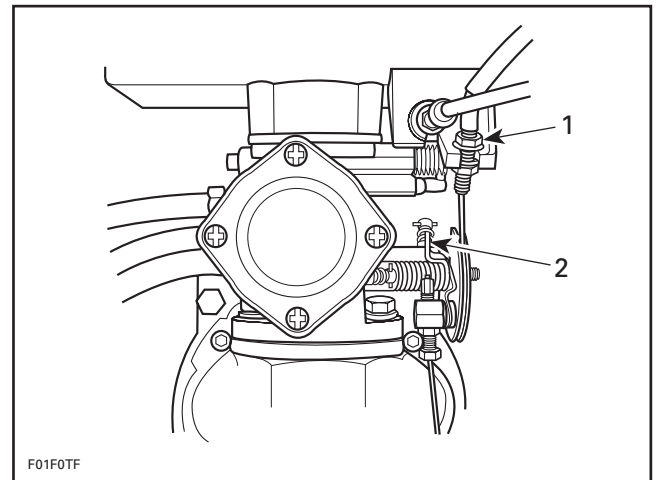

SINGLE CARB

1. Adjustment nut
2. Throttle lever stopper

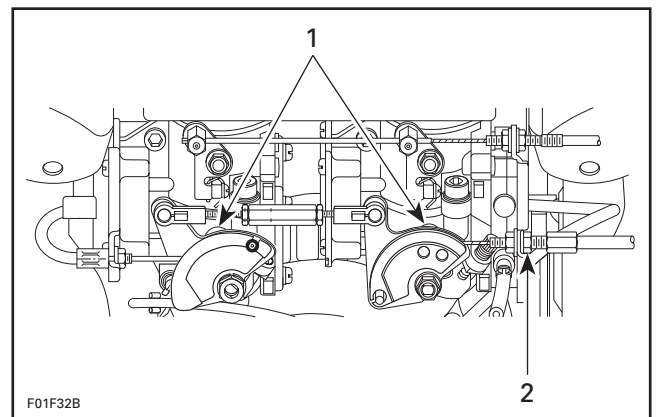

TWIN CARBS

1. Throttle lever stoppers (behind levers)
2. Adjustment nut

Tighten jam nut and recheck adjustment.

◆ WARNING

Make sure idle speed screw contacts stopper when throttle lever is fully released at handlebar.

After throttle cable adjustment, always proceed with oil injection pump adjustment. Refer to LUBRICATION SYSTEM 06-03.

▼ CAUTION

Improper oil injection pump synchronization with carburetor can cause serious engine damage.

Section 05 FUEL SYSTEM
Sub-Section 04 (CARBURETORS)

2, Low Speed Screw

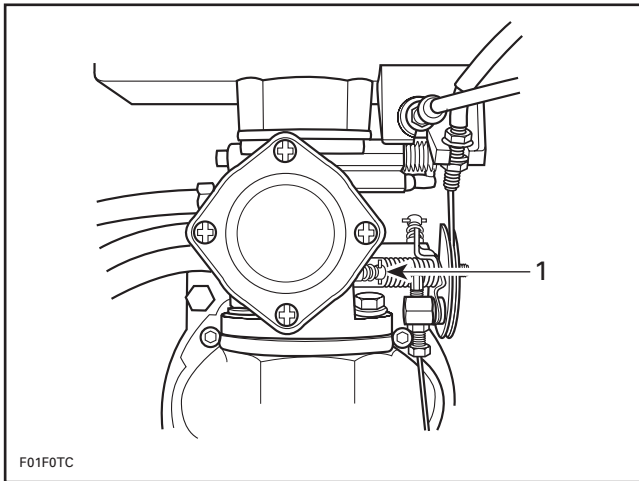

TYPICAL — SINGLE CARB

1. Low speed screw

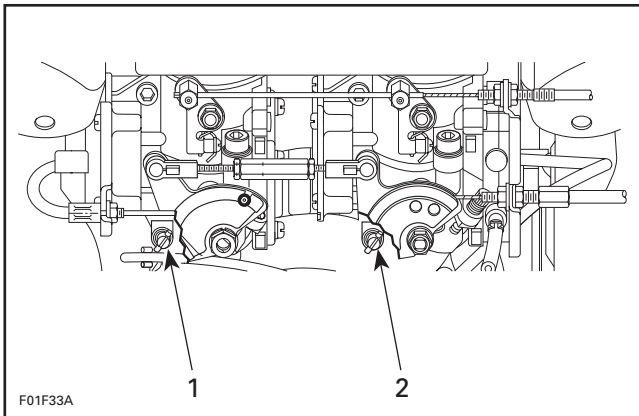

TWIN CARBS

1. Low speed screw (PTO)
 2. Low speed screw (MAG)

▼ CAUTION

Do not attempt to set engine idle speed with low-speed screw.

Tighten low speed screw until a slight resistance is felt. Then, back it off to the specification as per following chart.

Watercraft model	HX	SP/GS/GSI/GTS/GTI	SPX/XP/GSX/GTX
Low speed screw (turn)	1-1/2	1-3/4	1

NOTE: Turning screw clockwise leans mixture and turning screw counterclockwise enriches mixture.

Start and warm up engine.

▼ CAUTION

If watercraft is out of water, engine must be cooled using the flush kit.

Check that engine idles and runs smoothly. Make sure engine reacts quickly to throttle lever depression. If necessary, readjust low speed screw ($\pm 1/4$ turn).

NOTE: On twin carburetor engines, both low speed screws must be adjusted exactly the same way. Never adjust screws more than 1/4 turn at a time.

14, High Speed Screw

The high speed screw is sealed with a plastic cap that allows an adjustment of 1/4 turn.

NOTE: Turning screw 1/4 turn counterclockwise enriches mixture and turning screw clockwise leans mixture.

▼ CAUTION

Do not attempt to adjust high speed screw by removing plastic cap.

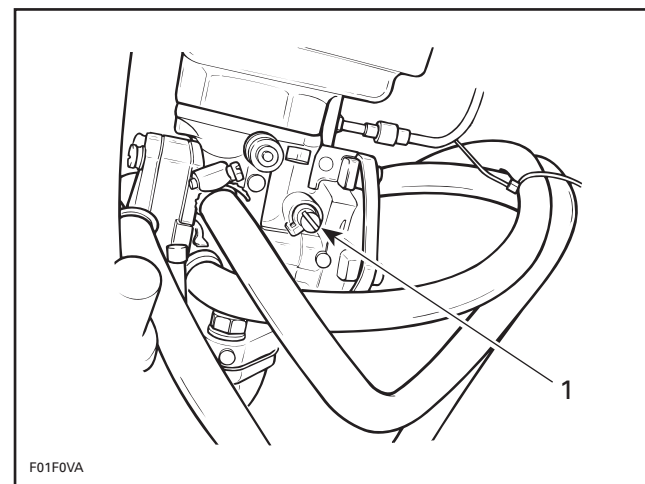

TYPICAL — SINGLE CARB

1. High speed screw

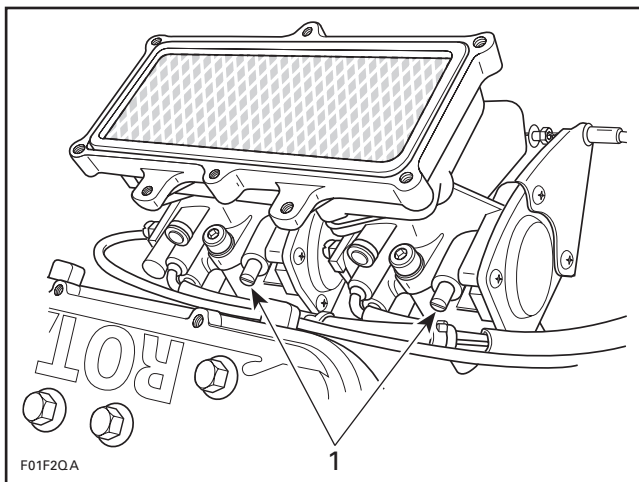

TYPICAL — TWIN CARBS

1. High speed screws

15, Idle Speed Screw

Turning screw clockwise increases engine idle speed and turning screw counterclockwise decreases engine idle speed.

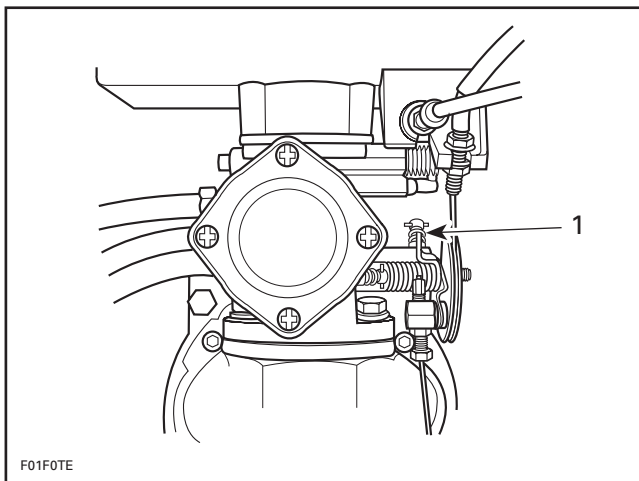

SINGLE CARB

1. Idle speed screw

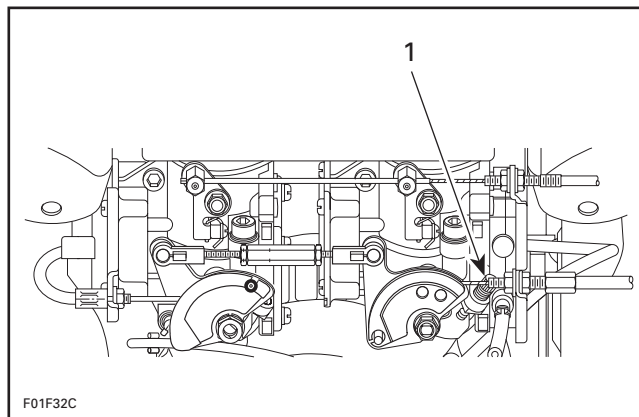

TWIN CARBS

1. Idle speed screw

NOTE: On twin carburetor engines, there is only one idle speed screw.

Connect an induction-type tachometer (P/N 295 000 100) on spark plug cable of magneto side to measure engine speed.

NOTE: To adjust idle speed, ensure flame arrester and air intake silencer are installed.

Start engine and bring to normal operating temperature.

▼ CAUTION

If watercraft is out of water, engine must be cooled using the flush kit.

Turn screw so that engine idles at 1500 RPM in water or 3000 RPM out of water.

TABLE OF CONTENTS

OIL INJECTION SYSTEM	06-02-1
GENERAL	06-02-4
OIL SYSTEM PRESSURIZATION	06-02-4

OIL INJECTION PUMP	06-03-1
REMOVAL.....	06-03-3
DISASSEMBLY.....	06-03-3
CLEANING	06-03-3
ASSEMBLY.....	06-03-3
ADJUSTMENTS	06-03-4
CHECKING OPERATION.....	06-03-6

OIL INJECTION SYSTEM

SP, SPX and GTS Models

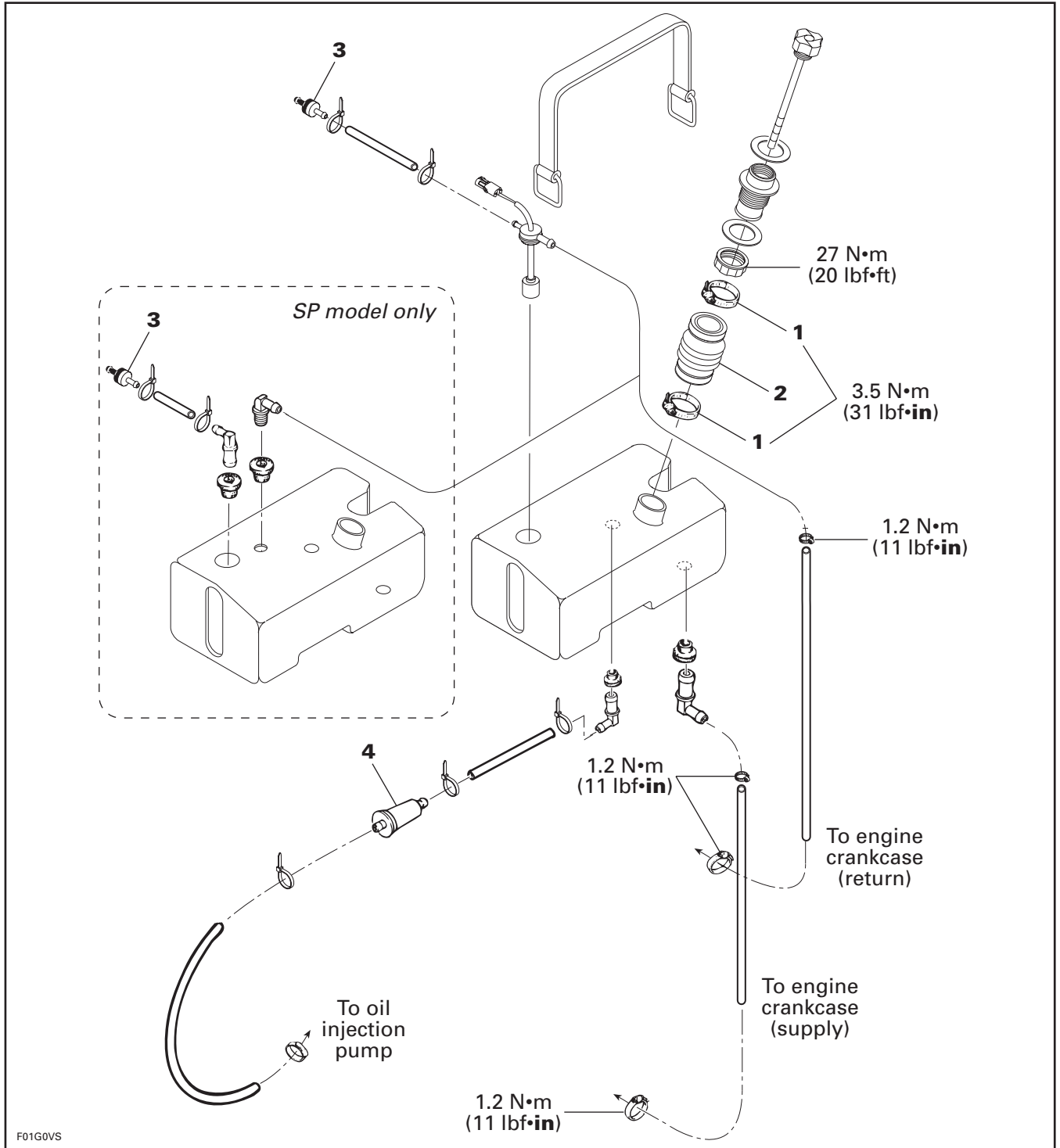

Section 06 LUBRICATION SYSTEM
Sub-Section 02 (OIL INJECTION SYSTEM)

XP and HX Models

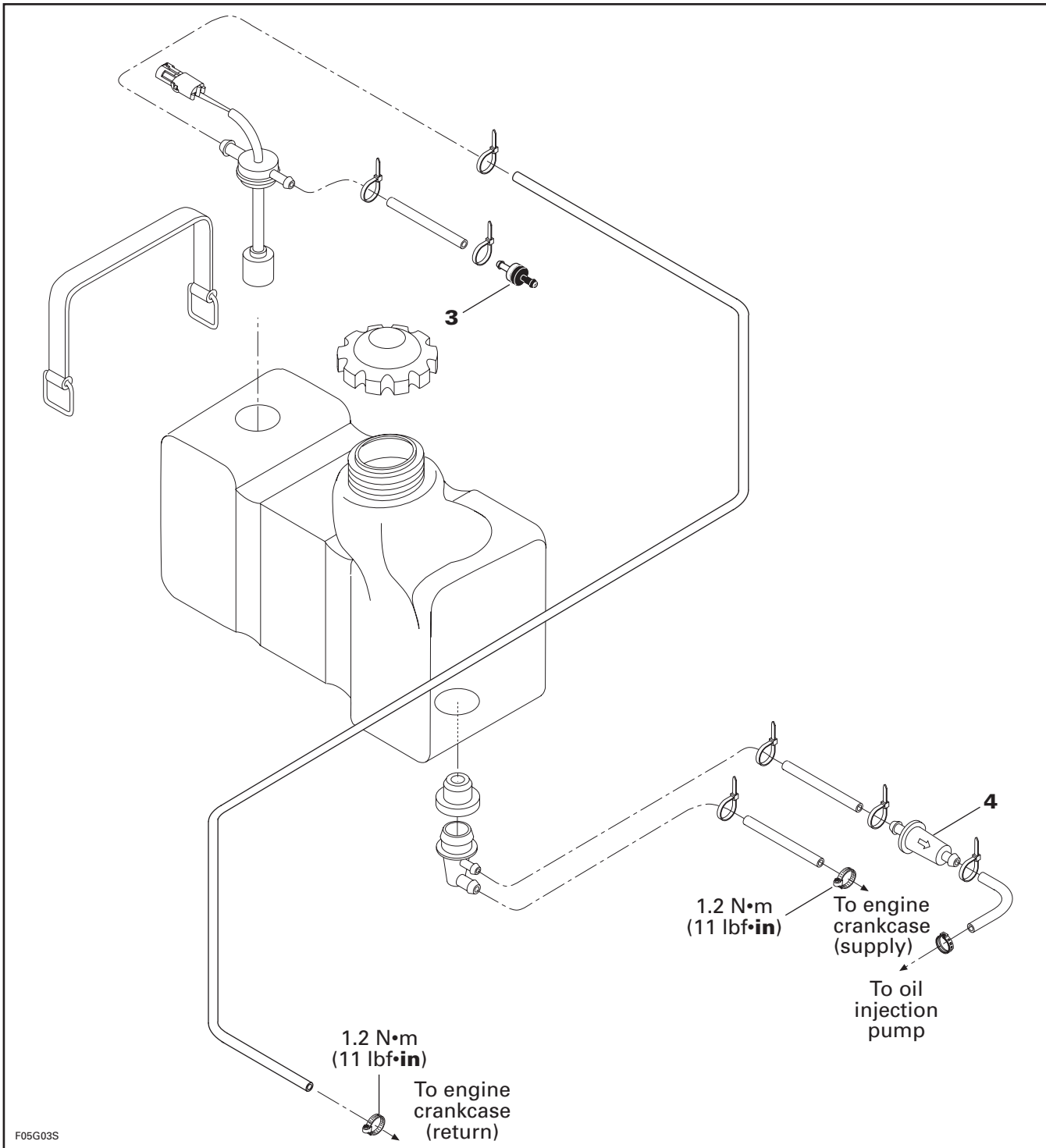

Section 06 LUBRICATION SYSTEM
Sub-Section 02 (OIL INJECTION SYSTEM)

GS, GSI, GSX, GTI and GTX Models

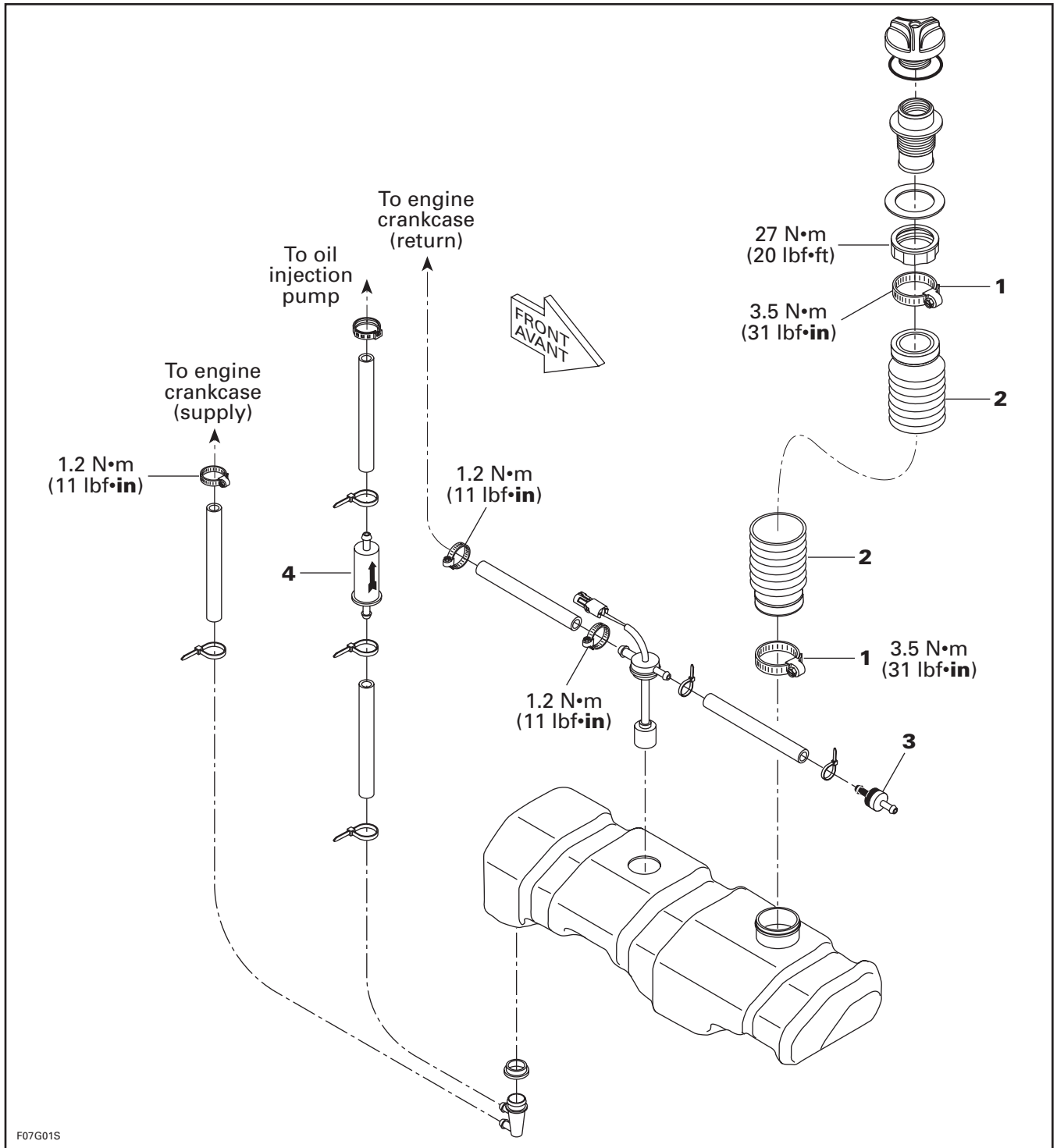

Section 06 LUBRICATION SYSTEM

Sub-Section 02 (OIL INJECTION SYSTEM)

GENERAL

Whenever repairing the oil injection system, always verify for water infiltration in reservoir.

Perform also a pressure test of the oil injection system.

All Models Except XP and HX

1,2, Clamp and Hose

Verify oil filler neck hose for damage. Always ensure that clamps are well positioned and tightened. Torque clamps to 3.5 N•m (31 lbf•in).

All Models

3, Check Valve

Black side of the one-way check valve is the valve outlet. It allows air to get in reservoir.

4, Oil Filter

Oil filter should be replaced annually.

OIL SYSTEM PRESSURIZATION

◆ WARNING

Whenever oil system components are disconnected or replaced, a pressure test must be done before starting engine. Ensure to verify oil line ends for damage. Always cut damaged end before reinstallation.

Pressure Test

Proceed as follows:

- Fill up oil reservoir.
- Install a hose pincher to rotary valve shaft oil supply hose.
- Install a hose pincher to rotary valve shaft oil return hose.
- Install a hose pincher to oil injection pump supply hose.
- Connect pump gauge tester (P/N 529 021 800) to check valve of oil injection reservoir vent.

NOTE: Use the same pump included in the ENGINE LEAK TESTER KIT (P/N 295 500 352).

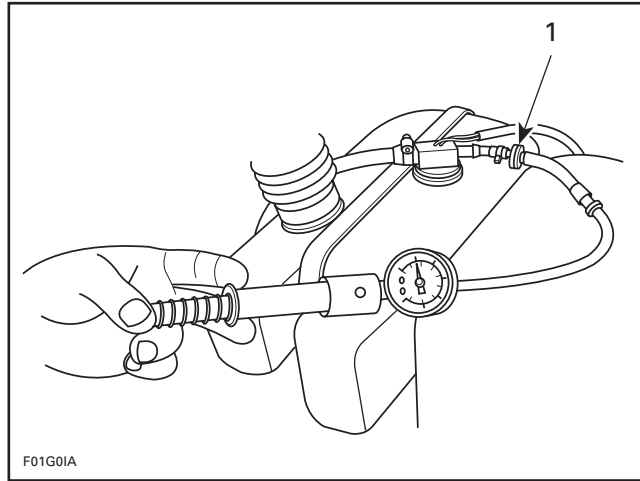

TYPICAL

1. Connect pump to check valve

- Pressurize oil system to 21 kPa (3 PSI). If pressure is not maintained, locate leak and repair/replace component leaking. To ease leak search spray a solution of soapy water on components, bubbles will indicate leak location.

NOTE: The system must maintain a pressure of 21 kPa (3 PSI) for at least 10 minutes. Never pressurize over 21 kPa (3 PSI).

▼ CAUTION

If any leak is found, do not start the engine and wipe off any oil leakage.

- Disconnect pump gauge tester and remove hose pinchers.

OIL INJECTION PUMP

717 Engines

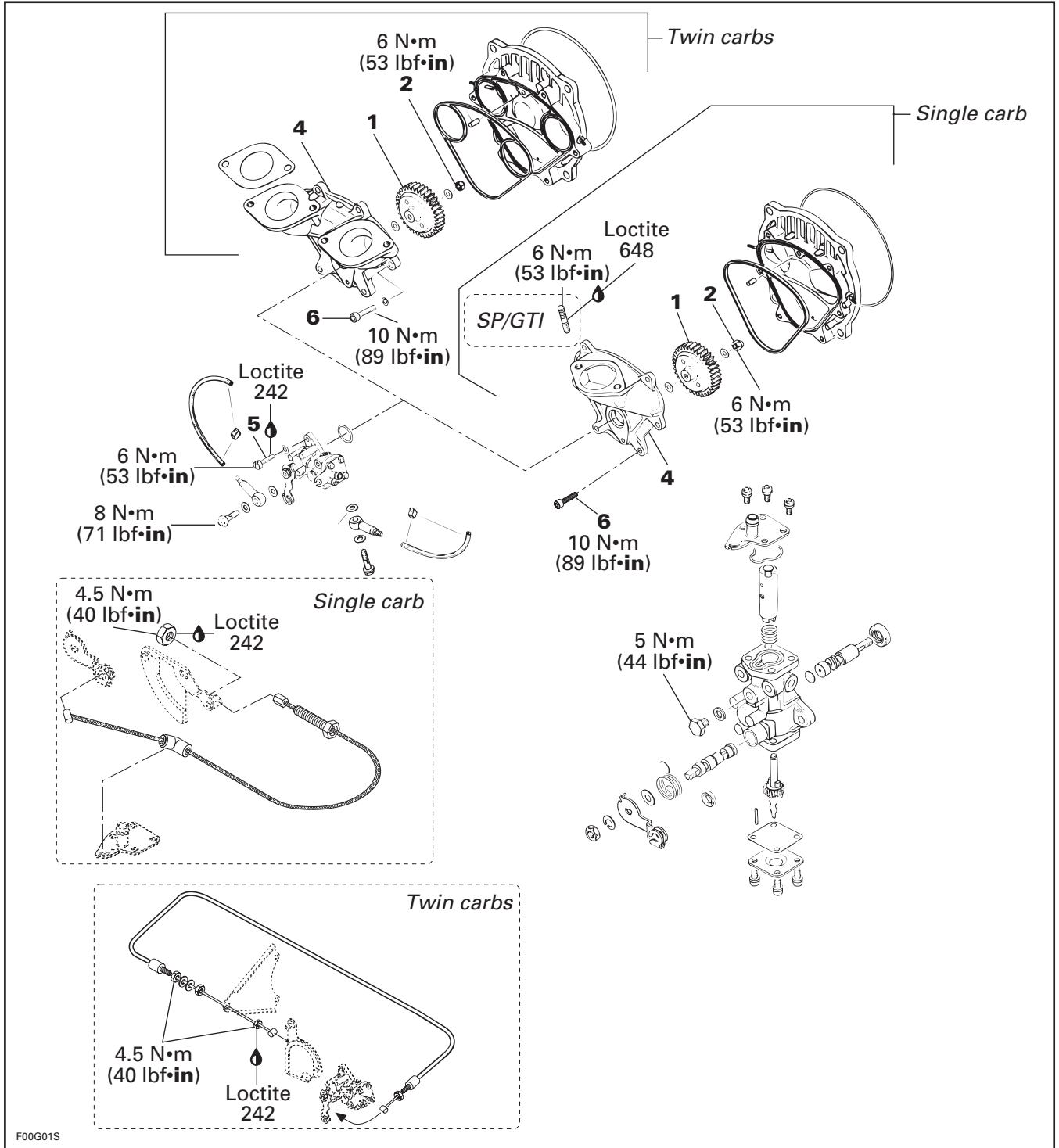

Section 06 LUBRICATION SYSTEM

Sub-Section 03 (OIL INJECTION PUMP)

787 Engine

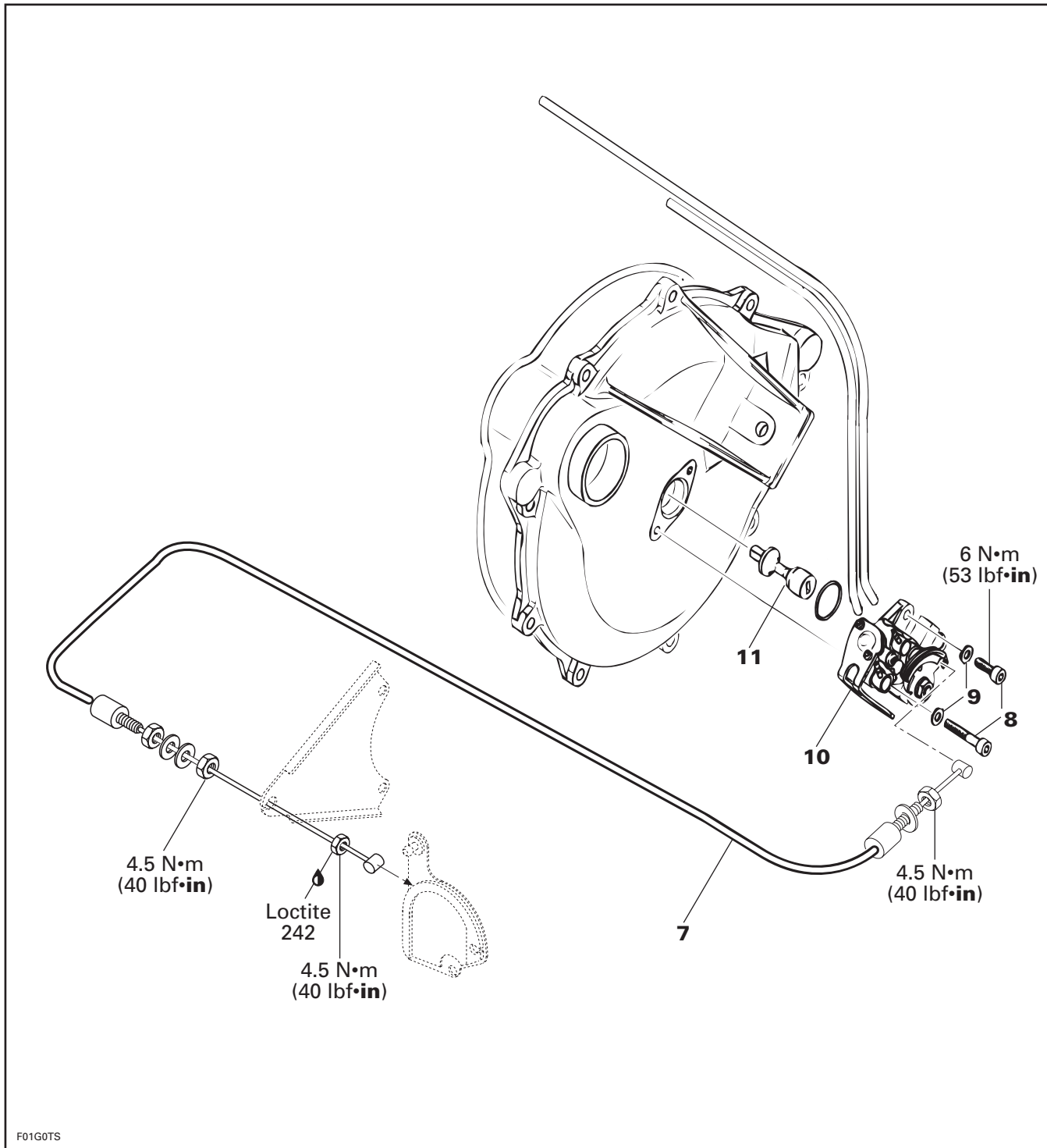

REMOVAL

717 Engines

Remove air intake silencer (refer to FUEL SYSTEM 05-03).

Remove rotary valve cover (refer to ENGINE 03-07).

Remove Allen screws **no. 6** retaining intake manifold **no. 4** to rotary valve cover.

Separate intake manifold from rotary valve cover.

1, Oil Pump Gear

To separate oil pump from intake manifold, remove oil pump gear using gear holder (P/N 290 277 905) and unscrew lock nut **no. 2**.

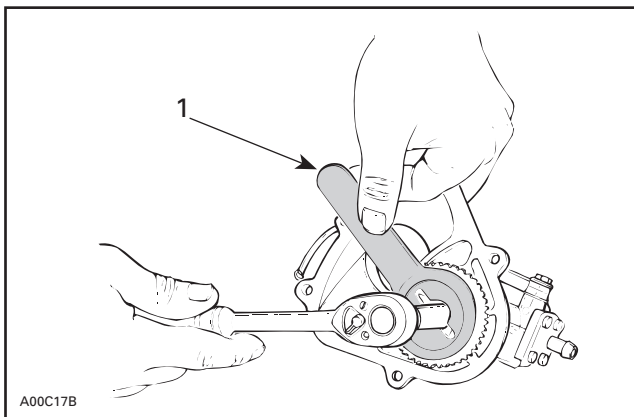

1. Gear holder

3, Oil Injection Pump

Remove 2 Allen screws **no. 5** with flat washers retaining oil injection pump to intake manifold.

Remove pump.

787 Engine

10, Oil Injection Pump

Disconnect oil injection pump cable **no. 7**.

Remove 2 Allen screws **no. 8** with flat washers **no. 9** retaining oil injection pump to magneto housing cover.

Pull pump and shaft **no. 11**.

Disconnect oil hoses from fittings of oil injection pump.

DISASSEMBLY

NOTE: Some oil pump parts are not available in single parts. A gasket set is available for the pump.

If the pump is found defective, it should be replaced by a new one.

CLEANING

Discard all seals and O-rings. Clean metal components in a solvent.

ASSEMBLY

717 Engines

3,4, Oil Injection Pump and Intake Manifold

Install oil injection pump to intake manifold. Torque screws **no. 5** to 6 N•m (53 lbf•in).

▼ CAUTION

Whenever oil injection lines are removed, always make the routing as shown.

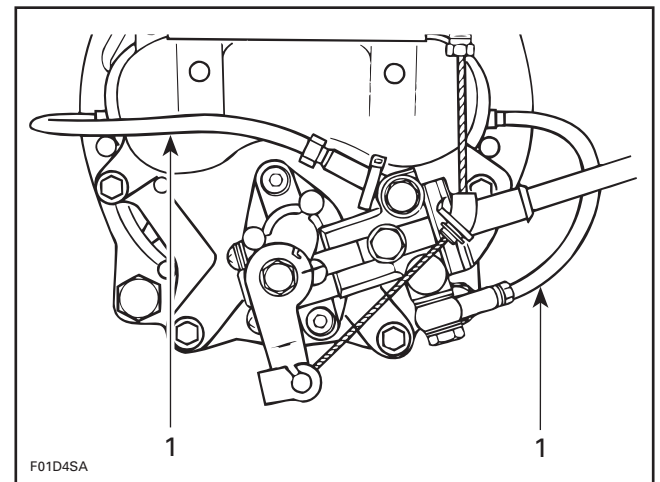

TYPICAL

1. Small oil line

1, Oil Pump Gear

Install gear to oil injection pump shaft. Torque lock nut **no. 2** to 6 N•m (53 lbf•in).

NOTE: Make sure one washer is installed on each side of gear.

Section 06 LUBRICATION SYSTEM

Sub-Section 03 (OIL INJECTION PUMP)

4, Intake Manifold

Install intake manifold to rotary valve cover and torque screws **no. 6** to 10 N•m (89 lbf•in).

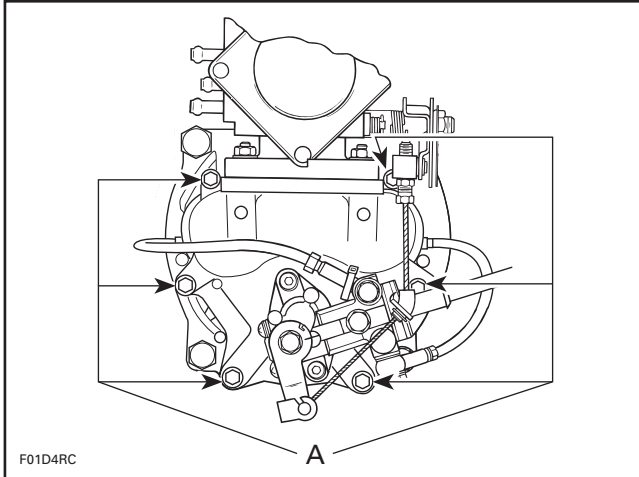

TYPICAL

A. 10 N•m (89 lbf•in)

787 Engine

10,11, Oil Injection Pump and Shaft

Install shaft **no. 11** in crankshaft end.

Install pump. Secure with flat washers **no. 9** and screws **no. 8**. Torque to 3 N•m (26 lbf•in).

Install oil injection pump cable.

ADJUSTMENTS

▼ CAUTION

As oil injection pump adjustment is dependent on throttle cable position, make sure to perform throttle cable adjustment first.

Preliminary Synchronization

NOTE: To check synchronization of pump as a routine maintenance, refer to **Final Synchronization**. Make sure idle speed of engine is properly adjusted.

Ensure carburetor butterfly(ies) is (are) in closed position.

NOTE: On a twin carburetor engine, make sure carburetors are properly synchronized. If necessary, refer to FUEL SYSTEM 05-04.

Turn idle speed screw until it contacts stopper.

Turn idle speed screw 2 turns.

Turn cable adjustment nut to align marks on pump.

NOTE: A mirror may be used to facilitate this verification.

717 Engines

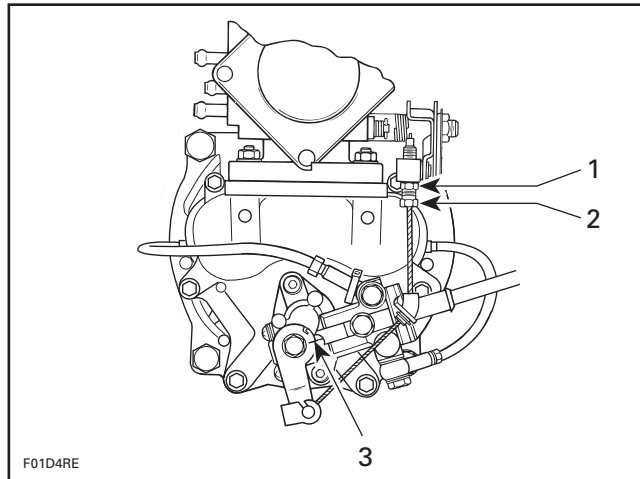

TYPICAL

1. Jam nut
2. Adjustment nut
3. Aligned marks

787 Engine

NOTE: The adjustment screw and jam nut for the oil injection pump cable are located at PTO carburetor lever.

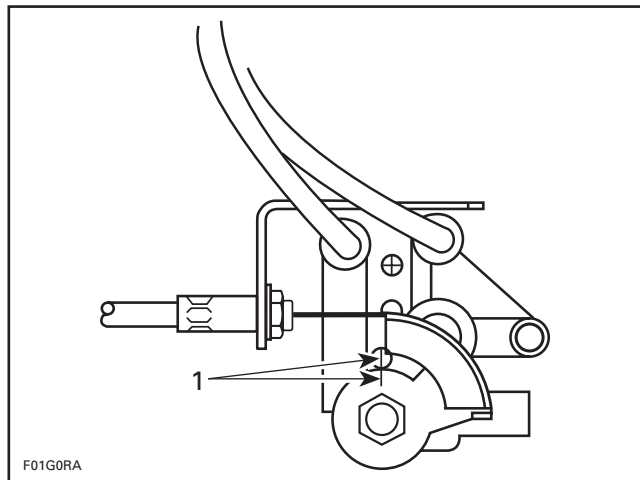

TYPICAL

1. Aligned marks

All Engines

Start and bring engine to normal operating temperature.

CAUTION

If watercraft is out of water, engine must be cooled using the flush kit. If air bubbles are present in the oil injection system, bleed system before operating engine.

Adjust idle speed to specification. Refer to FUEL SYSTEM 05-04.

Stop engine.

Final Synchronization

Eliminate throttle cable free-play by depressing throttle lever until a slight resistance is felt. In this position, marks on pump body and lever must align.

NOTE: A mirror may be used to facilitate this verification.

If necessary, turn cable adjustment screw to obtain pump mark alignment. Refer to above illustrations.

Tighten jam nut and recheck alignment marks.

CAUTION

Proper oil injection pump adjustment is very important. Any delay in the opening of pump can result in serious engine damage.

Bleeding

CAUTION

Oil injection system must be bled and adjustment checked before operating engine.

Ensure oil injection reservoir is sufficiently filled.

Install a dry rag below oil injection pump.

Loosen bleed screw to allow oil to flow.

717 Engines

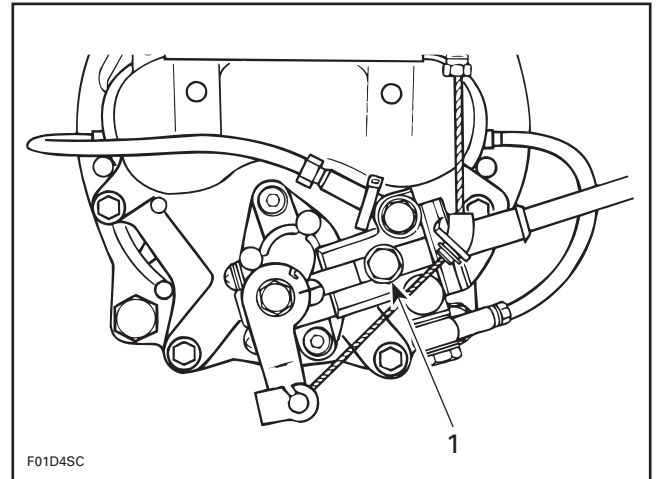

TYPICAL

1. Bleed screw

787 Engine

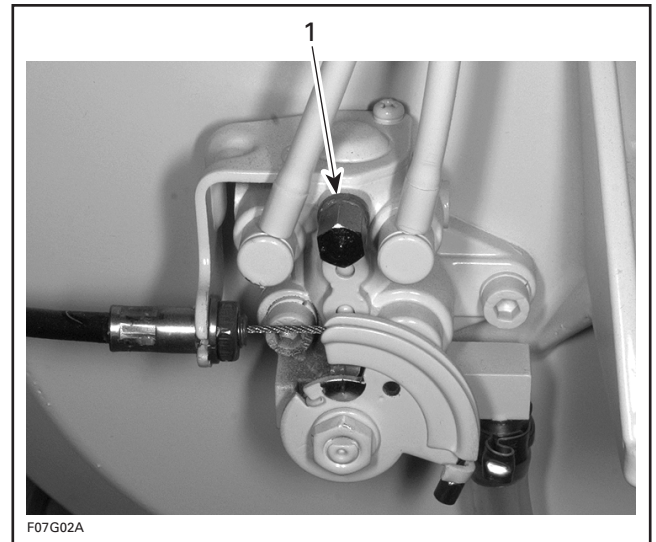

1. Bleed screw

All Engines

Keep bleeding until all air has escaped from line. Make sure no air bubbles remain in oil supply line.

Tighten bleed screw.

Wipe any oil spillage.

Check small oil lines between pump and intake manifold. They must be full of oil.

Section 06 LUBRICATION SYSTEM

Sub-Section 03 (OIL INJECTION PUMP)

If not, run engine at idle speed while manually holding pump lever in fully open position. Do not activate throttle lever.

▼ CAUTION

If watercraft is out of water, engine must be cooled using the flush kit.

CHECKING OPERATION

On Watercraft

NOTE: Oil line supply must be full of oil. See bleeding procedure above.

Start engine and run at idle while holding the pump lever in fully open position. Oil must advance into small oil lines.

NOTE: The engine should have a rich mixture, idling irregularly and emitting smoke at exhaust outlet.

If not, remove pump assembly and check the pump gear (717 engines) or shaft (787 engine) for defects, replace as necessary. Test pump as describes below:

NOTE: Through normal use, oil level must not drop in small tubes. If oil drops, verify check valve operation. Replace as necessary.

Bench Test

The oil pump must be removed out of watercraft. Connect a hose filled with injection oil to main line fitting. Insert other hose end in an injection oil container. Using a counterclockwise (reverse position) rotating drill rotate pump shaft. Oil must drip from fittings in parts of rotary valve cover while holding lever in a fully open position.

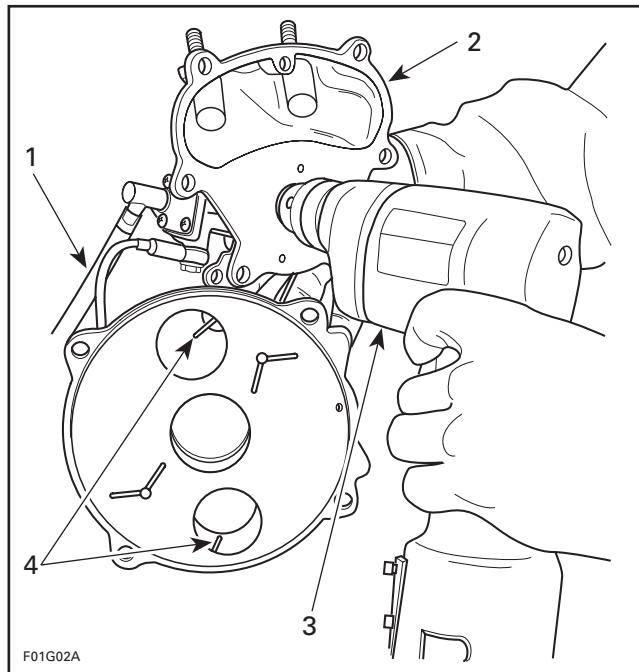

TYPICAL

1. Supply oil line to an oil container
2. Hold lever in fully open position
3. Counterclockwise (reverse) rotating drill
4. Oil must drip here

For an accurate test, each port should be checked separately to ensure equal delivery on both ports.

To obtain a precise result of the oil pump delivery rate, rotate it counterclockwise at 1500 RPM for a total time of 30 seconds.

NOTE: To ensure accuracy of test, oil lines should be completely filled before starting test.

Compare the results with the chart below. If oil pump is out of specification, replace it.

Engine	717/717D	787
Oil Pump Flow Rate at 1500 RPM (30 seconds)	1.24 – 1.51 mL (each port)	0.71 – 0.87ml (each port)

NOTE: Test can also be done at 3000 RPM. Double quantities in chart.

TABLE OF CONTENTS

IGNITION SYSTEM.....	07-02-1
GENERAL	07-02-1
IGNITION TIMING PROCEDURE	07-02-4
BOMBARDIER IGNITION TESTER	07-02-11
IGNITION SYSTEM TESTING PROCEDURE	07-02-11
SPARK PLUGS	07-02-16

CHARGING SYSTEM.....	07-03-1
GENERAL	07-03-1
TESTING PROCEDURE	07-03-1
BATTERY	07-03-4

STARTING SYSTEM	07-04-1
GENERAL	07-04-3
STARTING SYSTEM TROUBLESHOOTING	07-04-4
STARTER REMOVAL.....	07-04-5
STARTER DISASSEMBLY.....	07-04-5
CLEANING	07-04-5
PARTS INSPECTION	07-04-6
STARTER ASSEMBLY.....	07-04-6
STARTER INSTALLATION	07-04-8
STARTER SPECIFICATION	07-04-9

INSTRUMENTS AND ACCESSORIES	07-05-1
GENERAL	07-05-1
INSPECTION	07-05-1

DIGITALLY ENCODED SECURITY SYSTEM	07-06-1
GENERAL	07-06-1

IGNITION SYSTEM

GENERAL

717 Engines

The digital Capacitor Discharge Ignition (CDI) system includes the following components:

Magneto

It is the primary source of electrical energy. It transforms magnetic field into electric current.

The flywheel contains 4 permanent magnets and spins around the generating coil. This electric current flows to the ignition coil (SP, GTS and HX models) or the Multi-Purpose Electronic Module (GS, GSI and GTI models).

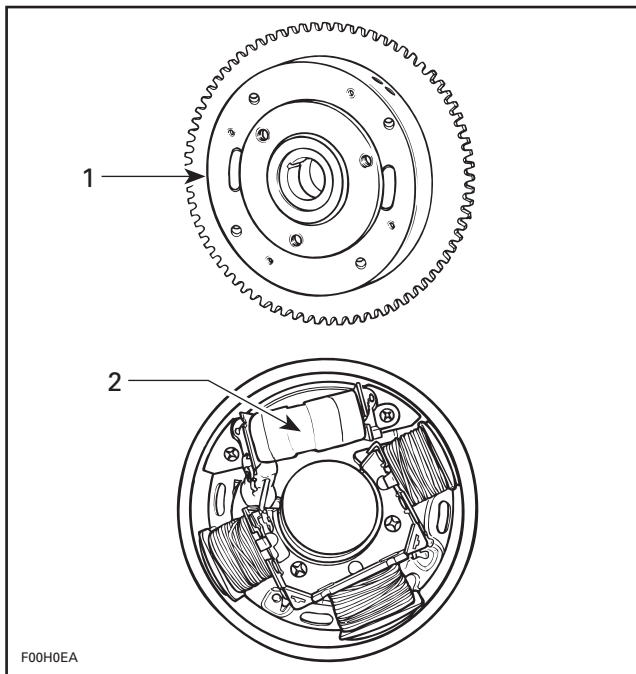

1. Flywheel
2. Generating coil

Ignition Coil

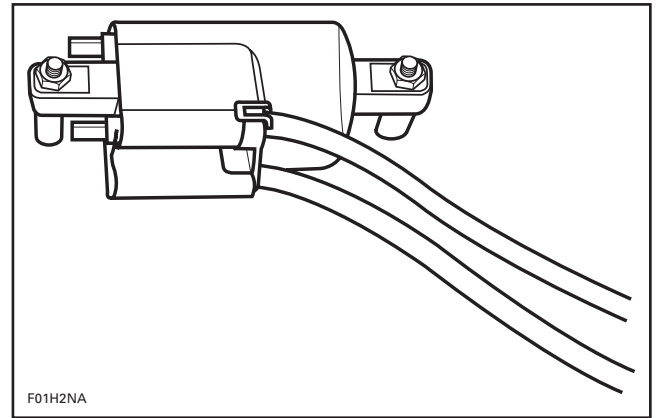

TYPICAL

SP, GTS and HX Models

The ignition coil performs two functions:

It has an integrated capacitor discharged ignition (CDI) module, which controls the spark occurrence (ignition timing curve).

Every half revolution of the flywheel, a critical point occurs when the position of the magnets changes the polarity of the current flowing from the generating coil.

The CDI module detects the change of polarity and signals at the right time the primary winding of the ignition coil.

The secondary winding of the ignition coil steps up the voltage input to high voltage current for both spark plugs.

GS, GSI and GTI Models

The ignition coil steps up the voltage input from the Multi-Purpose Electronic Module to high voltage current for both spark plugs.

The ignition coil is located in the rear electrical box, on right side of watercraft.

Multi-Purpose Electronic Module (MPEM)

The MPEM is directly powered by the battery. It has a micro-processor inside of its sealed case.

The MPEM is responsible of the following electrical functions:

- interpreting information
- distributing information

Section 07 ELECTRICAL SYSTEM

Sub-Section 02 (IGNITION SYSTEM)

- start/stop function
- timer
- Digitally Encoded Security System
- ignition (GS, GSI and GTI models)
- engine rev limiter

Fuses are directly mounted onto the MPEM.

SP, GTS and HX Models

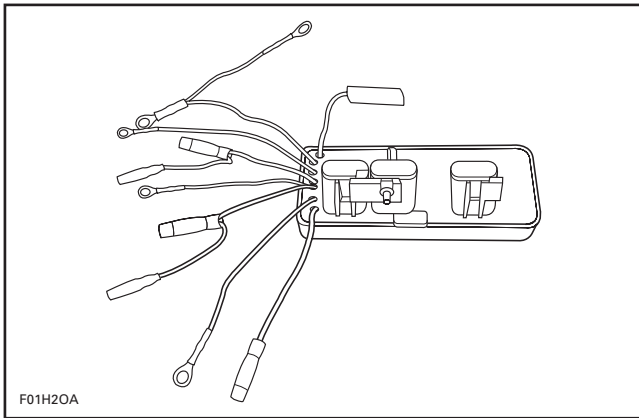

TYPICAL

GS, GSI, and GTI Models

On these models, the MPEM is also used as a junction box, eliminating the need of an electrical box.

All electrical components or accessories are directly linked to the MPEM.

Wire positions are identified with a series of numbers on the MPEM. AMP plug connectors are used.

The regulator/rectifier is also mounted on the MPEM.

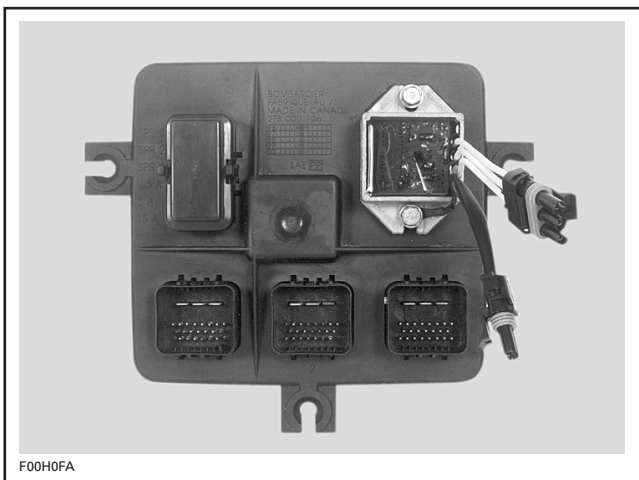

TYPICAL

787 Engine

The 787 engine has a digital Direct Current-Capacitor Discharge Ignition (DC-CDI) system.

Compared to the magneto system, the DC-CDI system offers a more powerful and stable ignition at low RPM.

SPX, GSX and GTX Models

The high amperage/voltage components are located into a rear electrical box (next to the battery).

XP Model

The high amperage/voltage components are located into a front electrical box.

SPX and GTX Models

The other components are located in the conventional electrical box.

GSX and XP Models

The other components are integrated to the Multi-Purpose Electronic Module (MPEM).

All Models with a 787 Engine

The ignition system includes the following components:

Battery

The battery is the primary power source for this system.



Trigger Coil

The trigger coil is mounted outside the rotor (inside the magneto housing of the engine) and is not adjustable.



Its purpose is to signal the engine position to the Multi-Purpose Electronic Module. The rotor has two protrusions (180 degrees apart) that, when coupled with the trigger coil, accomplish the signaling.

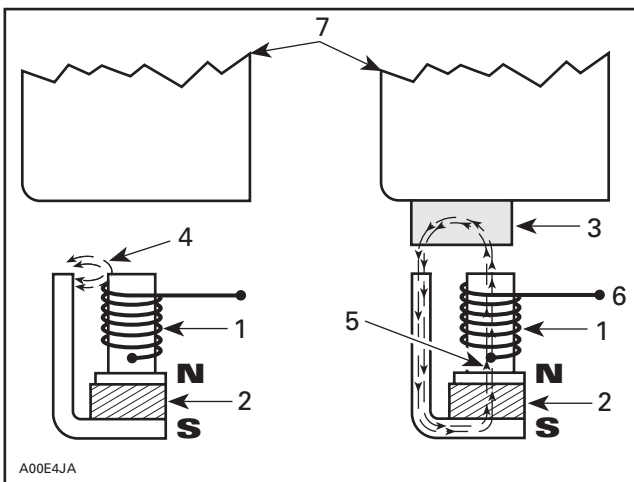

1. Coil
2. Magnet
3. Rotor protrusion
4. Magnetic field outside of coil
5. Magnetic field crossing coil
6. Current to MPEM

Multi-Purpose Electronic Module (MPEM)

The MPEM is directly powered by the battery. It has a micro-processor inside of its sealed case.

The MPEM is responsible of the following electrical functions:

- interpreting information
- distributing information
- start/stop function
- timer
- Digitally Encoded Security System
- ignition
- engine rev limiter

Fuses are directly mounted onto the MPEM.

SPX and GTX Models

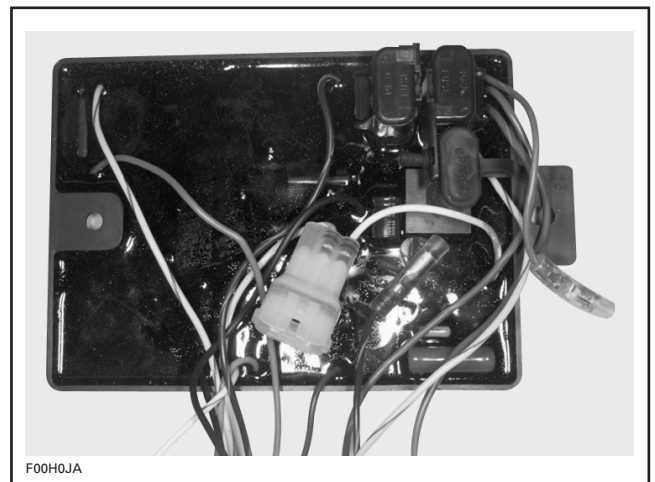

GSX and XP Models

On these models, the MPEM is also used as a junction box, eliminating the need of an electrical box.

All electrical components or accessories are directly linked to the MPEM.

Wire position are identified with a series of number on the MPEM. AMP plug connectors are used.

The regulator/rectifier is also mounted on the MPEM.

Section 07 ELECTRICAL SYSTEM

Sub-Section 02 (IGNITION SYSTEM)

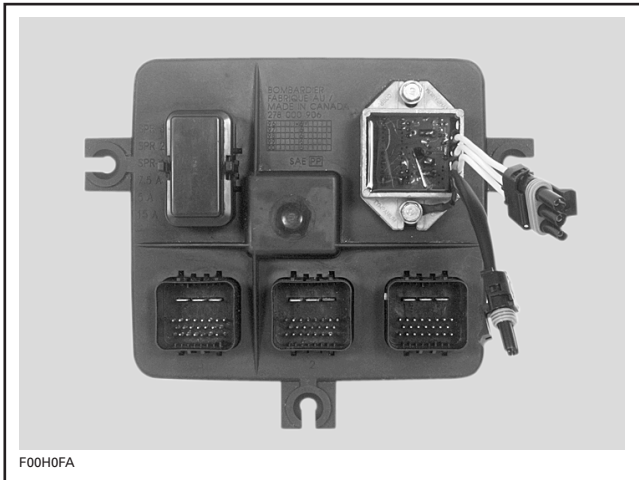

Ignition Coil

The ignition coil steps up the voltage input from the Multi-Purpose Electronic Module to high voltage current for both spark plugs.

IGNITION TIMING PROCEDURE

Before checking ignition timing with a stroboscopic timing light (dynamic test), it is mandatory to scribe a timing mark on the PTO flywheel (static test) corresponding to the specific engine.

Also, the timing mark scribed on the PTO flywheel can be used to troubleshoot a broken magneto woodruff key.

NOTE: Do not use the factory mark found on the PTO flywheel to check ignition timing or troubleshoot any problems.



CAUTION

The relation between the PTO flywheel mark position and crankshaft position may change as the PTO flywheel is screwed on the crankshaft. As an example, when the PTO flywheel is reinstalled on the crankshaft, it can slightly turn on the crankshaft when the engine is accelerated, even if it is properly torqued. This is enough to obtain a false ignition timing reading. Always verify PTO flywheel mark position before checking ignition timing with an appropriate timing light.

787 Engine

Normally ignition timing adjustment should not be required. It has been set at factory and it should remain correctly adjusted since every part is fixed and not adjustable. The only time the ignition timing might have to be changed would be when replacing the crankshaft, the magneto rotor, the trigger coil and the MPEM. If the ignition timing is found incorrect, you should first check for proper crankshaft alignment. This might be the indication of a twisted crankshaft.

With this DC-CDI system, the ignition timing can be checked with either the engine hot or cold. Also, the ignition timing is to be checked at 3500 RPM with the timing light.

Between 3000 and 4000 RPM, the spark advance does not change. So when checking ignition timing at 3500 RPM, a change in engine speed within ± 500 RPM will not affect the timing mark when checked with the timing light.

Static Test

All Engines

1. Disconnect MAG side spark plug wire and connect wire to grounding device then remove spark plug.
2. Remove PTO flywheel guard.

Section 07 ELECTRICAL SYSTEM
Sub-Section 02 (IGNITION SYSTEM)

717 Engines

3. Install timing mark pointer tool on engine using wing nuts previously removed.

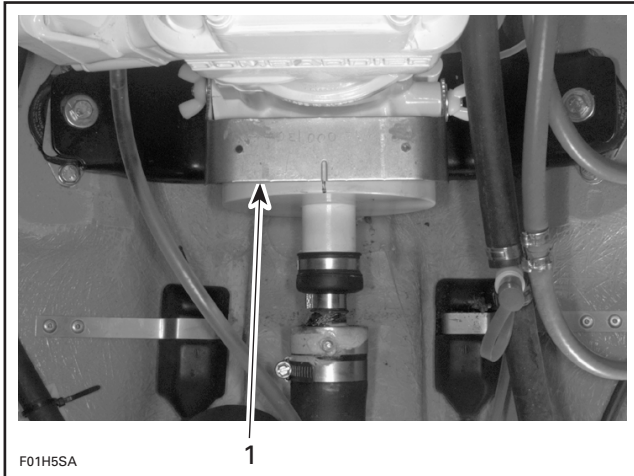

1. Timing mark pointer tool (P/N 295 000 130)

787 Engine

3. Remove middle screw securing the engine to the rear engine mount. Reinstall screw with timing mark pointer tool.

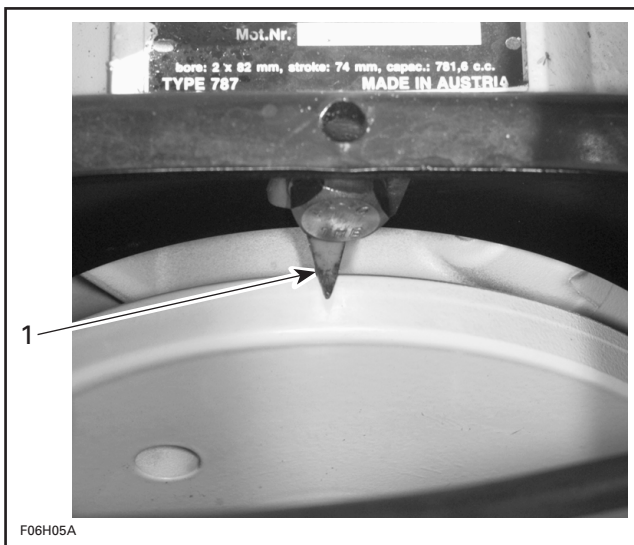

1. Timing mark pointer tool (P/N 295 000 135)

All Engines

4. Install and adjust a TDC gauge (P/N 295 000 143) in MAG side spark plug hole.

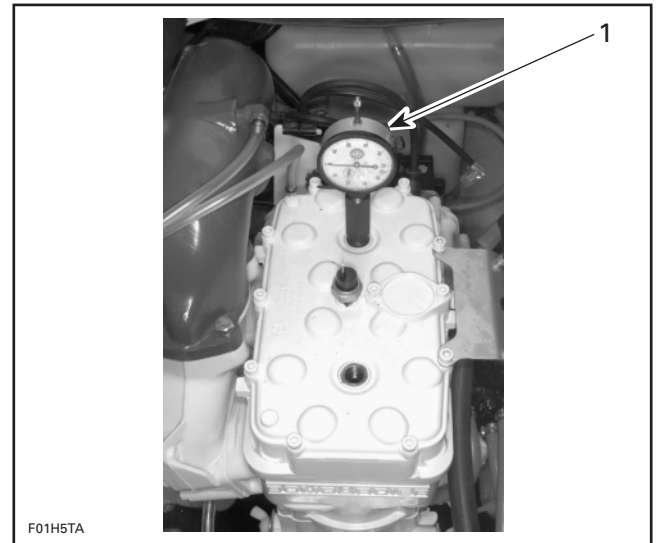

TYPICAL

1. TDC gauge on MAG side

5. Rotate PTO flywheel counterclockwise (when facing it) until piston is at top dead center.

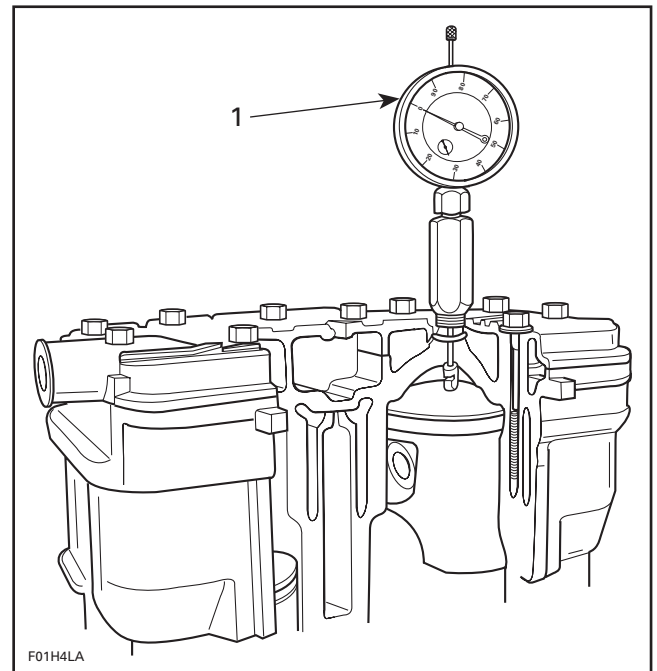

TYPICAL

1. Adjust gauge dial at zero

6. From this point, rotate flywheel clockwise to reach proper specification according to engine. Refer to the following chart.

Section 07 ELECTRICAL SYSTEM

Sub-Section 02 (IGNITION SYSTEM)

ENGINE	IGNITION TIMING (BTDC)
717D/717	2.59 mm (.102 in)
787	3.38 mm (.133 in)

7. Scribe a thin mark on PTO flywheel in the middle of tool slot (717 engines) or aligned with timing mark pointer tool (787 engine).

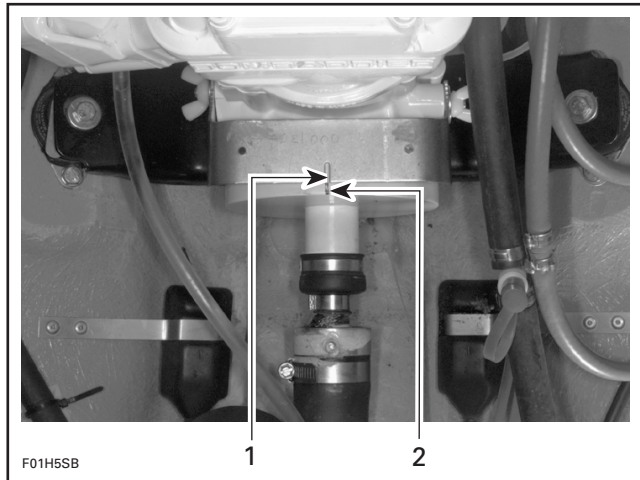

TYPICAL

1. Tool slot
2. Flywheel mark

NOTE: This mark becomes the reference when using the stroboscopic timing light.

▼ CAUTION

The static test cannot be used as a timing procedure, therefore, always check the timing with a stroboscopic timing light.

8. Remove TDC gauge.
9. Reinstall spark plug and connect wire.

Dynamic Test

To check ignition timing, use Bombardier timing light (P/N 529 031 900).



717 Engines

NOTE: To perform this procedure, make sure to use a stroboscopic timing light rated up to 6000 RPM. Otherwise, an inaccurate reading will be obtained.

The ignition components are affected by temperature variation, therefore, timing must be checked when engine is cold, after idling for a MAXIMUM of 20 seconds.

1. Connect an induction-type tachometer (P/N 295 000 100) to spark plug wire.

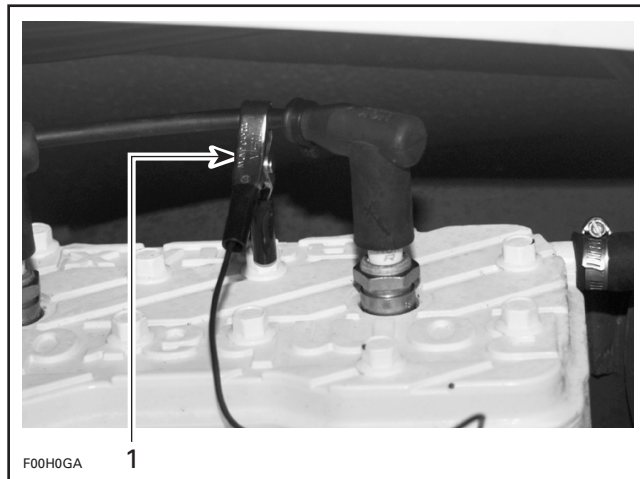

1. Tachometer pick-up
2. Connect timing light pick-up to MAG side spark plug wire.

Section 07 ELECTRICAL SYSTEM

Sub-Section 02 (IGNITION SYSTEM)

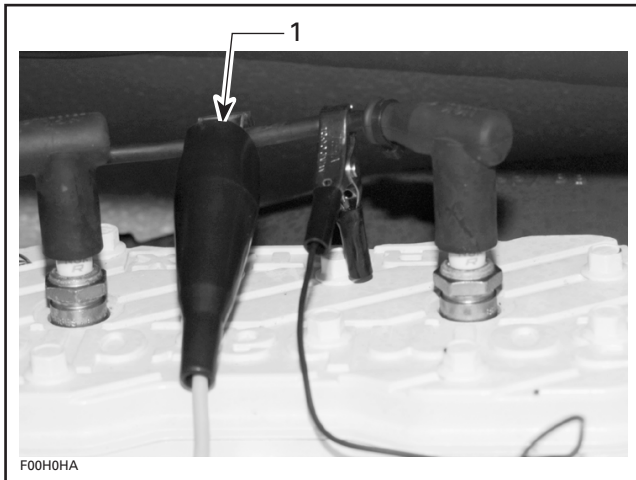

1. Timing light pick-up

3. Start engine and point timing light straight in line with timing tool slot. Bring engine to the specified RPM as per following table:

ENGINE	RPM
717D	5500
717	6000

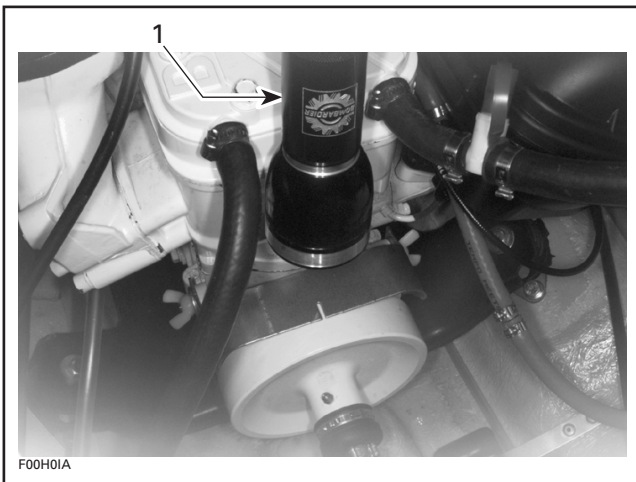

1. Timing light straight in line with tool slot

▼ CAUTION

If engine is to be run more than a few seconds, engine must be cooled using the flush kit.

4. Check if PTO flywheel mark aligns with timing tool slot.

NOTE: On this system, timing advance decreases as engine speed increases.

If timing mark aligns with tool slot, timing is properly set. If not, refer to **Ignition Timing Adjustment** in this sub-section.

787 Engine

1. Connect an induction-type tachometer (P/N 295 000 100) to spark plug wire.

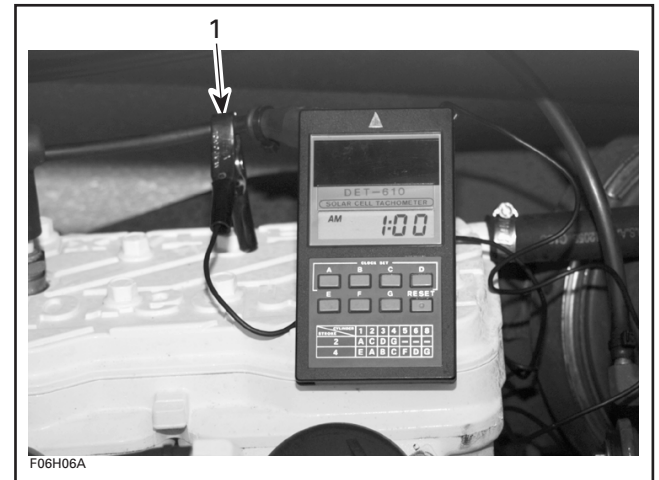

1. Tachometer pick-up

2. Connect timing light pick-up to MAG side spark plug wire.

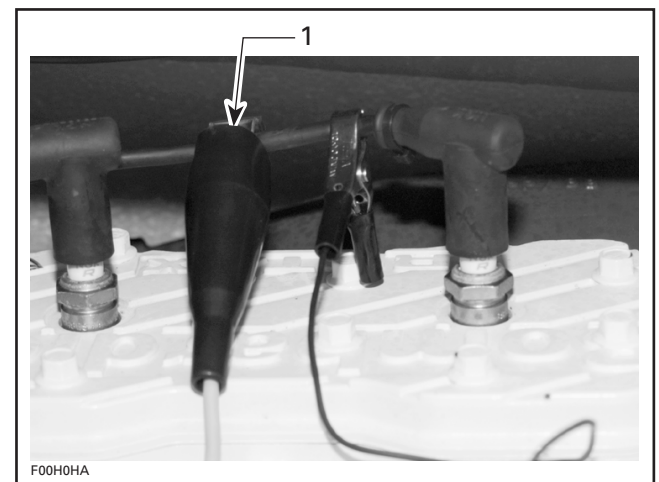

1. Timing light pick-up

3. Rev the engine to 3500 RPM and point beam of timing light straight in line with timing mark pointer.

Section 07 ELECTRICAL SYSTEM

Sub-Section 02 (IGNITION SYSTEM)

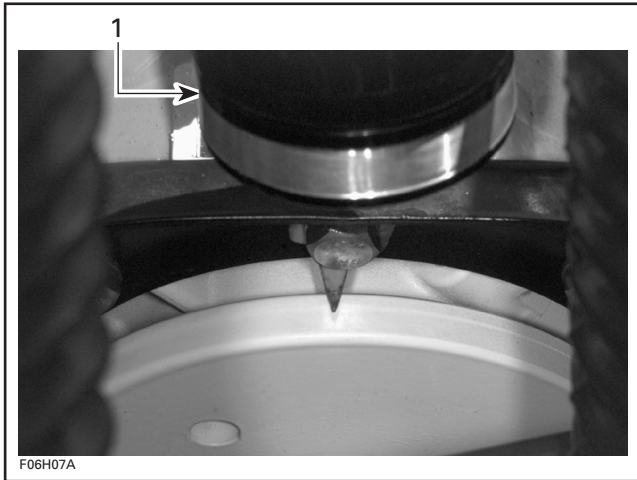

1. Timing light straight in line with tool slot

▼ CAUTION

If engine is to be run more than a few seconds, engine must be cooled using the flush kit.

NOTE: If mark on PTO flywheel is perfectly aligned with timing mark pointer, no adjustment is required. If it is not the case, refer to **Ignition Timing Adjustment** in this sub-section.

Ignition Timing Adjustment

717 Engines

Remove battery (SP and GTS models).

Remove magneto housing cover and wire support.

For removal of magneto, refer to ENGINE 03-04.

Timing is performed by moving armature plate; clockwise to retard spark occurrence or counter-clockwise to advance.

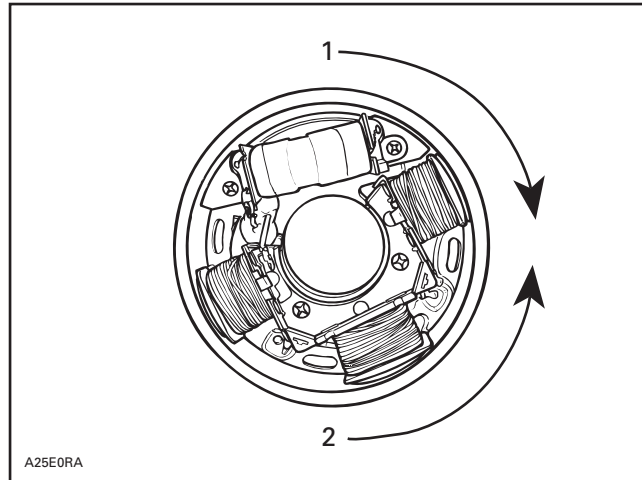

TYPICAL

1. To retard
2. To advance

To adjust, loosen 3 armature plate retaining screws and slightly rotate armature plate in proper direction.

NOTE: As a guideline, turn the armature plate the same amount needed to align mark on PTO flywheel.

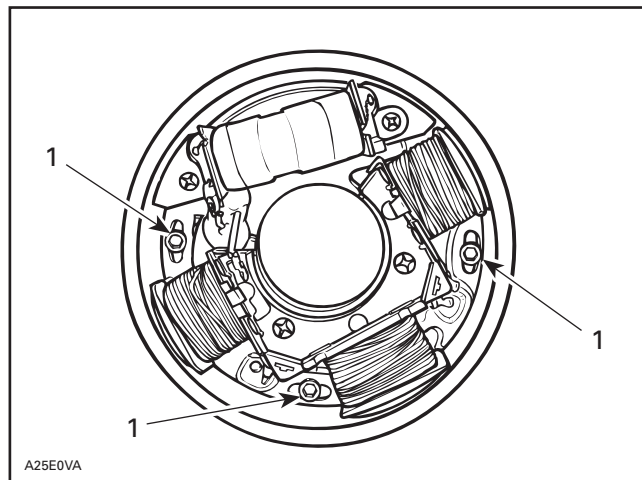

TYPICAL

1. Retaining screw

Example 1

When PTO flywheel mark is on right side of timing tool slot, it indicates advanced timing.

Section 07 ELECTRICAL SYSTEM
Sub-Section 02 (IGNITION SYSTEM)

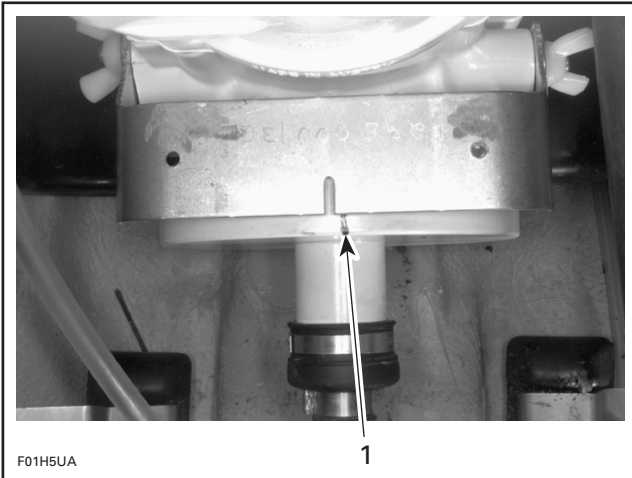

1. Too advanced timing

In this case, turn armature plate clockwise when facing it.

Example 2

When PTO flywheel mark is on left side of timing tool slot, it indicates retarded timing.

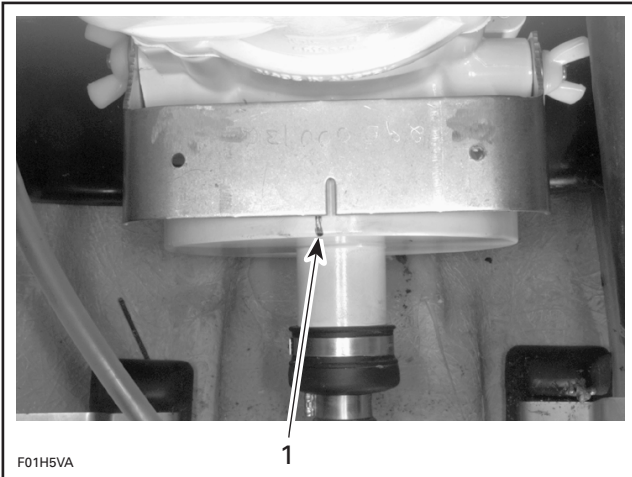

1. Retarded timing

In this case, turn armature plate counterclockwise when facing it.

After adjustment, tighten armature plate retaining screws.

<p>▼ CAUTION</p>
<p>Armature plate screws must have Loctite 242 (blue) applied before tightening. Make sure armature plate screws are well secured.</p>

Reinstall removed parts. Refer to ENGINE 03-04.

Recheck ignition timing (make sure engine is cold).

Repeat armature plate positioning procedure if timing mark position is not adequate.

787 Engine

To correct the ignition timing, the data of the MPEM is changed using the MPEM programmer (P/N 295 000 127).

NOTE: For more information on the programmer, refer to its guide.

Through the MPEM programmer, the ignition timing can be advanced up to 3° or retarded up to 4°.

<p>▼ CAUTION</p>
<p>If the ignition timing is adjusted too advanced, this will cause serious damage to the engine.</p>

The timing mark refer to the physical component position when the spark must occur. The MPEM must be synchronized with the mark. For instance, on a particular engine, the timing correction may need to be advanced to 2° so that the mark aligns with timing mark pointer tool. This is not the real spark advance, just a correction for the tolerances of the mechanical components.

Knowing that, you select with the programmer the higher or lower number to advance or retard the actual timing correction by referring to the following chart.

TIMING CORRECTION CHART	
Programmer number (MPEM)	Ignition Timing Correction
2	3°
3	2°
4	1°
1	0
5	-1°
6	-2°
7	-3°
8	-4°

Section 07 ELECTRICAL SYSTEM

Sub-Section 02 (IGNITION SYSTEM)

Examples:

- a. You found the flywheel mark advanced. You must retard the ignition timing.
- The programmer gives you the number 3. Referring to the chart, number 3 returns a correction of 2° (advanced) and this is too much in this case.
 - You estimate the correction should be set to 1° (advanced) to align flywheel mark. Back in the chart, look to find 1° (advanced). This gives number 4. Enter this number with the programmer.
 - You recheck the timing with the timing light and if the mark is aligned, ignition timing is properly set.
- b. You found the flywheel mark advanced. You must retard the ignition timing.
- The programmer gives you the number 3. Referring to the chart, number 3 returns a correction of 2° (advanced) and this is too much in this case.
 - You estimate the correction should be set to 1° (advanced) to align flywheel mark. Back in the chart, look to find 1° (advanced). This gives number 4. Enter this number with the programmer.
 - You recheck the timing with the timing light and found that the flywheel mark is still too advanced. You know now that the correction made previously was not enough and you estimate the correction should be set to - 2° (retarded) to align flywheel mark. Back in the chart, look to find - 2° (retarded). This gives number 6. Enter this number with the programmer.
 - You recheck the timing with the timing light and if the mark is aligned, ignition timing is properly set.
- c. You found the flywheel mark retarded. You must advance the ignition timing.
- The programmer gives you the number 4. Referring to the chart, number 4 returns a correction of 1° (advanced) and this is not enough in this case.
 - You estimate the correction should be set to 2° (advanced) to align flywheel mark. Back in the chart, look to find 2° (advanced). This gives number 3. Enter this number with the programmer.

- You recheck the timing with the timing light and if the mark is aligned, the ignition timing is properly set.

Proceed as follows to adjust the ignition timing with the MPEM programmer:

1. Connect the communication cable to the MPEM programmer and the other end to the safety lanyard switch on the craft.
2. Press the **ON/C** button on programmer and enter your password.
3. Press **3** to choose *Vehicle info* in programmer.
4. Press **4** to choose *Engine param.*
5. Press **2** to choose *Timing adjust.*
6. The programmer display a number that is stored in the MPEM.
7. Press \leftrightarrow to choose **yes** for modify then press **Enter**.
8. Now punch in the number that corresponds to the degree you want for the ignition timing then press **Enter**.
9. Press **Menu** to go back one level.
10. Press **8** to choose *Save + Quit* (even if item no. 8 is not visible on the display, it is active when you select it).
11. Press **Enter** to confirm yes you want to *save modifications* to the MPEM.
12. You must see *Operation successful*. This confirms that the new timing data has been stored in the MPEM.
13. Unplug communication cable from safety lanyard switch on craft.
14. Press **Off** to close the programmer.

At this point, you can install the watercraft safety lanyard and start the engine to check the effect of the correction on the ignition timing. If further adjustment is required, repeat the procedure.

NOTE: The MPEM features a permanent (non-volatile) memory and keeps the ignition timing programmed even when the watercraft battery is disconnected.

BOMBARDIER IGNITION TESTER

Use of Bombardier Ignition Tester

This tester (P/N 295 000 008) can verify generating coil (717 engines) and ignition coil of the ignition system.

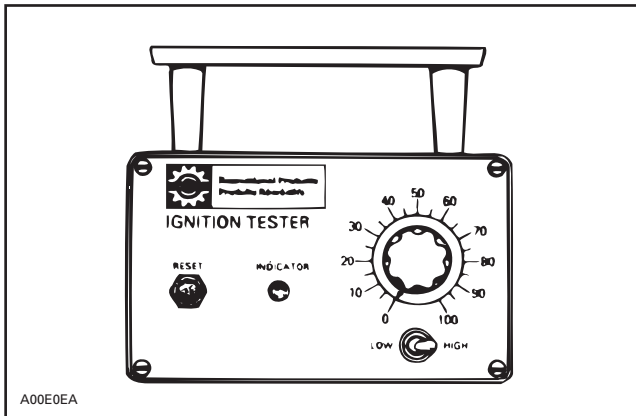

Always make sure that tester batteries are in good condition.

Test Condition

All tests are performed on watercraft at cranking speed with spark plugs installed.

Always proceed in the following order:

1. Connect tester P and N clip leads as indicated for each specific test.
2. Follow test procedure sequence.
3. Install cap over safety lanyard switch and crank engine until light turns on, or otherwise, for a maximum of 5 seconds.
4. After every test that lights the indicator lamp, RESET the indicator circuit by depressing the reset button.

Analysis of Test Results

INDICATOR LAMP LIGHTS AT SPECIFIC SETTING

Output is as specified. Test results should repeat 3 times. If readings do not repeat, output is erratic and cause should be investigated (loose connections or components, etc.).

INDICATOR LAMP LIGHTS AT LOWER SETTING

This indicates that the output is less than that designed to operate in a satisfactory manner. However, before coming to the conclusion of a faulty condition be certain that correct engine cranking conditions were met before condemning the tested part.

INDICATOR LAMP DOES NOT LIGHT

One component is defective. Proceed as instructed to find defective component.

INTERMITTENT IGNITION PROBLEMS

In dealing with intermittent problems there is no easy diagnosis. For example, problems that occur only at normal engine operating temperature have to be tested under similar conditions.

In most cases of temperature and/or vibration failure, only parts replacement can solve the problem as most of these failures return to normal when engine is not running.

MULTIPLE PROBLEMS

There is always the possibility of more than one faulty part. If after a component has been replaced, the problem still persists, carefully repeat the complete test procedure to find the other faulty part.

SAFETY PRECAUTIONS

◆ WARNING

To prevent powerful electric shocks while cranking engine, neither touch any electronic ignition components (ignition coil, high tension wires, etc.) nor tester lead clips. Also make sure that tester leads do not touch any metallic object. Ventilate bilge at least two minutes prior to performing any test.

IGNITION SYSTEM TESTING PROCEDURE

When dealing with ignition problems, the following items should be verified in this order:

1. Spark occurrence/spark plug condition.
2. Battery condition.
3. Electrical connections.
4. Engine start/stop switch.
5. Safety lanyard switch.

Section 07 ELECTRICAL SYSTEM

Sub-Section 02 (IGNITION SYSTEM)

6. Timer.
7. Multi-Purpose Electronic Module (MPEM).
8. Magneto output (717 engines).
9. Ignition coil output.

 **CAUTION**

Whenever replacing a component in ignition system, check ignition timing.

NOTE: To perform verification, a good quality multimeter such as Fluke 73 (P/N 529 022 000) should be used.

Engine Start/Stop Switch Verification

Disconnect the YELLOW/RED wire of the start/stop switch. Using an ohmmeter, connect test probes to YELLOW/RED wire and to ground.

Measure resistance, it must be an open circuit (switch is normally open). Depress and hold switch, the ohmmeter should read close to 0 ohm.

Safety Lanyard Switch Verification

If 2 short beeps are not heard when installing the safety lanyard, refer to ELECTRICAL SYSTEM 07-06.

The following continuity tests can also be performed using an ohmmeter:

Disconnect switch wires.

Safety Lanyard Removed

Connect test probes to switch BLACK and BLACK/YELLOW wires. Measure resistance, there should be no continuity (open circuit).

Connect one test probe to the WHITE/GRAY wire and the other test probe to the switch terminal. Measure resistance, it must be close to 0 ohm.

Connect one test probe to the BLACK wire and the other test probe to the switch ring. Measure resistance, it must be close to 0 ohm.

Safety Lanyard on Switch

Connect test probes to switch BLACK and BLACK/YELLOW wires. Measure resistance, it must be close to 0 ohm.

Timer Verification

The timer is integrated into the MPEM.

Always confirm first that the fuses are in good condition.

To confirm operation of timer, remove safety lanyard from switch. After a 5 seconds delay, depress start/stop button once. The timer should stay on for about 33 seconds (for example, gauge(s) will be activated) and then turn off.

Rev Limiter Verification

To check engine rev limiter, connect an induction tachometer (P/N 295 000 100), start engine and check its maximum speed; it should be at 5900 ± 50 RPM for a 717D engine, 7000 ± 50 RPM for a 717 engine, and 7200 ± 50 RPM for a 787 engine.

Multi-Purpose Electronic Module (MPEM) Verification

SP, GTS and HX Models

The multi-purpose electronic module testing must be done with all wires disconnected from circuit. Otherwise testing equipment (ohmmeter) could be damaged.

 **CAUTION**

When disconnecting wires, BLACK/RED wire must never touch solenoid positive terminal. When replacing a MPEM, make sure to replace it with the right model.

Refer to the following chart for MPEM testing. Always respect polarity in chart.

Section 07 ELECTRICAL SYSTEM
Sub-Section 02 (IGNITION SYSTEM)

Meter (+) lead	Meter (-)	Value
Red (ring terminal)	Red (female terminal)	< 1Ω
Red (ring terminal)	Red/Purple (female terminal)	< 1Ω
Red (ring terminal)	Black (ring terminal)	> 20 kΩ
Black/Red	Black (ring terminal)	> 10 kΩ
White/Grey	Black (ring terminal)	> 100 kΩ
Tan/Black	Black (ring terminal)	> 200 kΩ
Yellow/Red (female terminal)	Black (ring terminal)	> 10 kΩ
Yellow/Red (male terminal)	Black (ring terminal)	> 50 kΩ
Black (ring terminal)	Red (ring terminal)	> 10 kΩ

Most of circuit can be tested with an ohmmeter but a 100% test doesn't mean the MPEM is in perfect condition.

▼ CAUTION
Whenever connecting MPEM, always have battery disconnected from circuit. If MPEM must be connected when circuit is activated, always connect BLACK/RED wire first to ignition coil/CDI module to prevent wire from touching solenoid positive terminal.

717 Engines

Generating Coil Verification

STATIC TEST

Disconnect magneto wiring harness connector.

Install the four-pin magneto harness adapter (P/N 295 000 131).

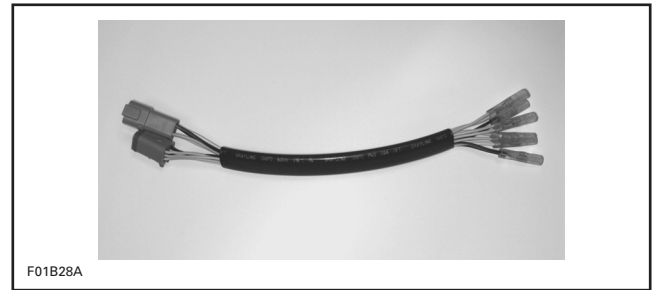

TYPICAL

Check resistance with a high-sensitivity ohmmeter. Refer to the following table for values and wire colors.

PART NAME	ADAPTER WIRE	RESISTANCE
Generating coil	Black with RED/BLUE	40-76 Ω

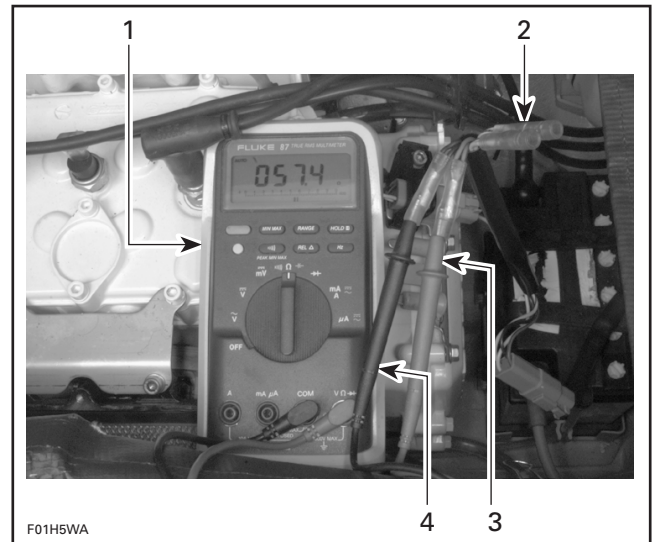

1. Multimeter
2. Four-pin magneto harness adapter
3. RED/BLUE wire
4. BLACK wire

DYNAMIC TEST

1. Connect spark plug cables to grounding device.
2. Disconnect magneto wiring harness connector.
3. Install the four-pin magneto harness adapter (P/N 295 000 131).
4. Connect probe "N" of Bombardier Ignition Tester to RED/BLUE wire of four-pin magneto harness adapter.
5. Connect probe "P" of Bombardier Ignition Tester to BLACK wire of four-pin magneto harness adapter.

Section 07 ELECTRICAL SYSTEM

Sub-Section 02 (IGNITION SYSTEM)

6. Set Bombardier Ignition Tester as per following table:

Tester probe	Adapter wire	Tester switch position	Tester dial position
N	RED/BLUE	LOW	60
P	BLACK		

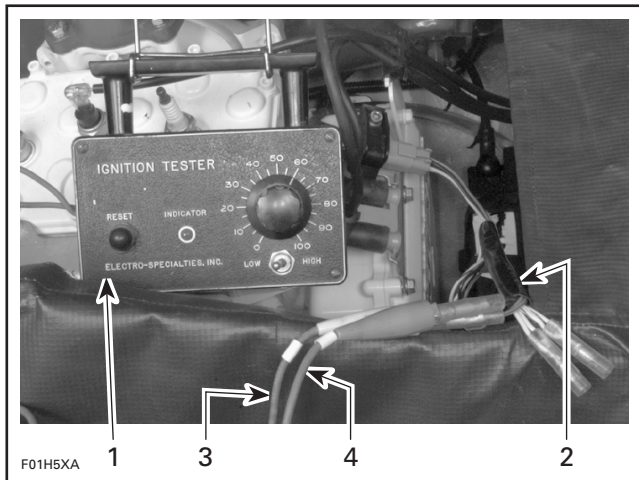

1. Bombardier ignition tester
2. Four-pin magneto harness adapter
3. Probe "N" to RED/BLUE wire
4. Probe "P" to BLACK wire

7. Crank engine and observe indicator.
8. Push reset button and repeat test twice.

Results:

- a. **Indicator lamp lights:** Generating coil output is up to specifications.
- b. **Indicator lamp does not light:** The problem is a faulty generating coil. Replace it.

787 Engine

Trigger Coil Verification

STATIC TEST: CONTINUITY

1. Disconnect magneto wiring harness connector.
2. Install the six-pin magneto harness adapter (P/N 295 000 136).

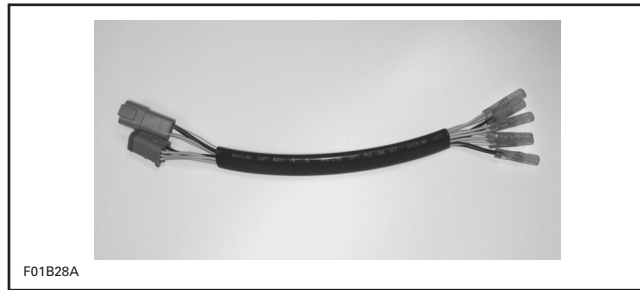

3. Connect one multimeter lead to the WHITE wire of the six-pin magneto harness adapter.
4. Connect the other multimeter lead to the BLACK/YELLOW wire of the six-pin magneto harness adapter.
5. Measure resistance; it should be between 190-300 ohms.

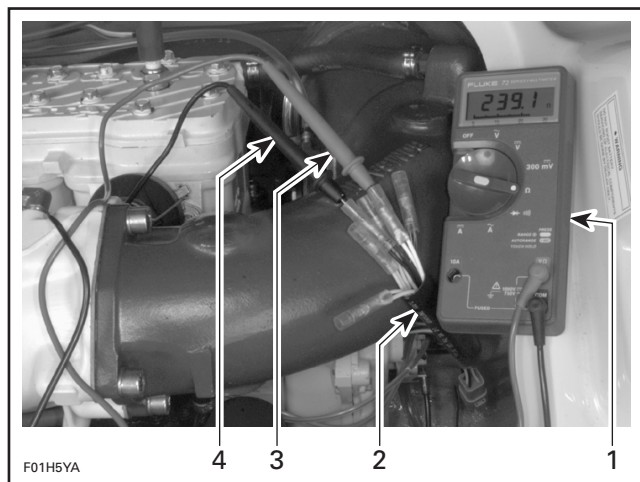

1. Multimeter
2. Six-pin magneto harness adapter
3. WHITE wire
4. BLACK/YELLOW wire

All Engines

Ignition Coil Verification

STATIC TEST

NOTE: An ignition coil with good resistance measurement can still be faulty. Voltage leak can occur at high voltage level which is not detectable with an ohmmeter.

Primary Winding

SP, GTS and HX Models

Due to the integrated CDI module, it is not possible to take any resistance measurement.

Section 07 ELECTRICAL SYSTEM

Sub-Section 02 (IGNITION SYSTEM)

All Other Models

1. Remove the 2 female spade connectors from the primary side of the ignition coil.
2. With the meter set on the resistance scale, connect the meter leads to the primary terminals of the coil.
3. Resistance should be between 0.34 - 0.62 ohm.

Secondary Winding

The spark plug caps must be removed from high tension cables, because they are resistor caps. The cap resistance is 4.48 K ohms.

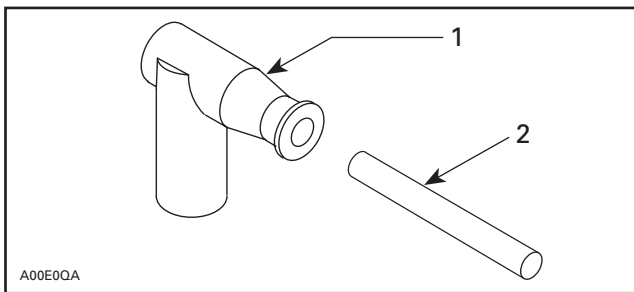

1. Resistor cap
2. High-tension cable

IGNITION COIL		
PART NAME	WIRE	RESISTANCE
Secondary winding (SP/GTS/HX)	End of each spark plug cable, spark plug caps removed	9 - 15 kΩ
Secondary winding (all other models)	End of each spark plug cable, spark plug caps removed	8.4 - 15.6 kΩ

NOTE: A short circuit will read 0 ohm (or close to) on ohmmeter.

DYNAMIC TEST

A paper clip of approximately 20 mm (3/4 in) will be used as a test adapter for the following test.

1. Install the test adapter to spark plug cable close to MAG side spark plug.

2. Connect Bombardier Ignition Tester probes then set switch and dial as follows:

Tester probe	Component	Tester switch position	Tester dial position
N	Tester adapter (paper clip) on spark plug cable	LOW	50
P	Grounding device		

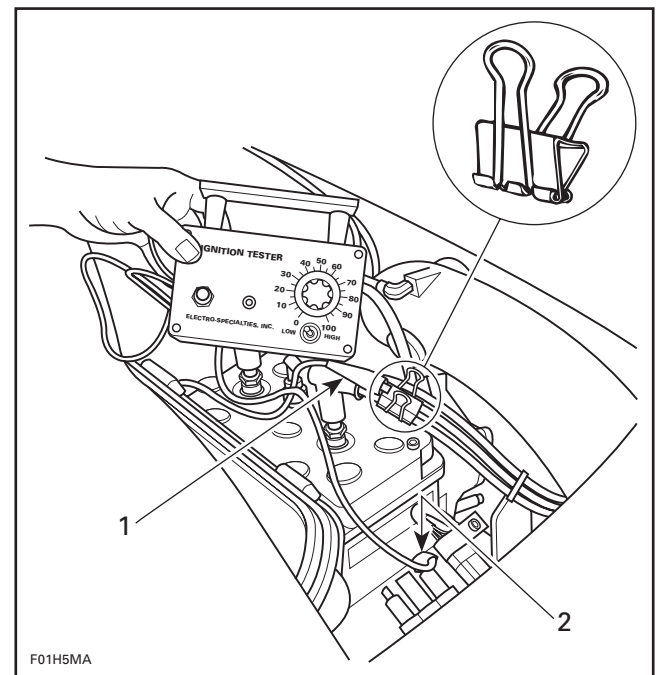

TYPICAL

1. "N" lead on paper clip
2. "P" lead to grounding device

3. Start engine and observe indicator.

NOTE: If engine starts, allow it to idle while observing indicator. Then, shut engine off.

4. Push reset button and repeat test twice.

Results:

- a. **Indicator lamp lights:** Ignition coil is OK.
- b. **Indicator lamp does not light:** Ignition coil is faulty. Replace it.

Section 07 ELECTRICAL SYSTEM

Sub-Section 02 (IGNITION SYSTEM)

All Models Except SP, GTS and HX

As an alternate method, use KOWA ignition coil tester (or equivalent), available from after-market tool/equipment suppliers.



CAUTION

Do NOT use coil tester on metal work bench.
Follow manufacturer instructions.

1. With ignition coil removed from craft, disconnect spark plug caps from high tension cables.
2. Hook high tension leads from tester to ignition coil high tension cables.
3. Connect 2 smaller tester leads to primary of ignition coil.

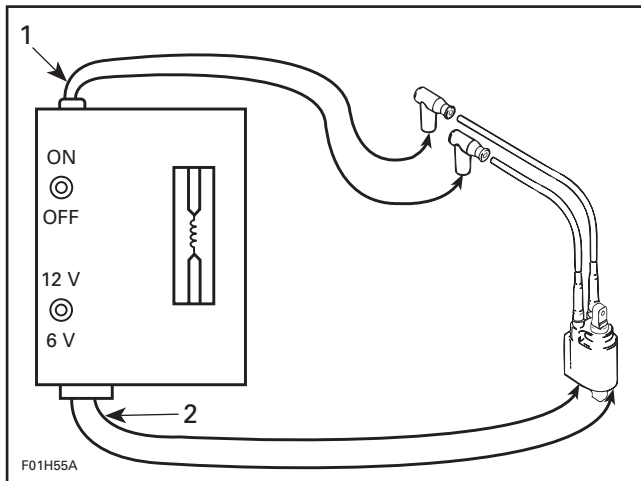

TYPICAL

1. Leads to secondary
2. Leads to primary

4. Turn power switch to 12 volts and you should observe spark jumping at a predetermined gap of 7 to 8 mm (.276 to .311 in).

If there is no spark, if it is weak or intermittent, the coil is defective and should be replaced.

SPARK PLUGS

Disassembly

First unscrew the spark plug one turn.

Clean the spark plug and cylinder head with pressurize air then completely unscrew.

Heat Range

The proper heat range of the spark plugs is determined by the spark plugs ability to dissipate the heat generated by combustion.

The longer the heat path between the electrode tip to the plug shell, the hotter the spark plug operating temperature will be — and inversely, the shorter the heat path, the colder the operating temperature will be.

A “cold” type plug has a relatively short insulator nose and transfers heat very rapidly into the cylinder head.

Such a plug is used in heavy duty or continuous high speed operation to avoid overheating.

The “hot” type plug has a longer insulator nose and transfers heat more slowly away from its firing end. It runs hotter and burns off combustion deposits which might tend to foul the plug during prolonged idle or low speed operation.

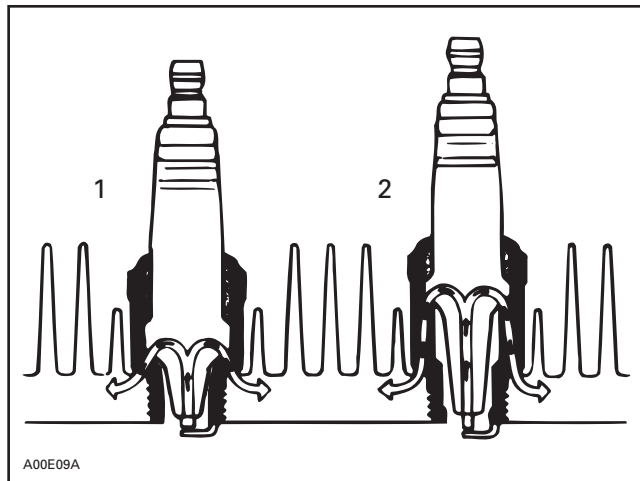

1. Cold
2. Hot



CAUTION

Severe engine damage might occur if a wrong heat range plug is used.

A too “hot” plug will result in overheating and pre-ignition, etc.

A too “cold” plug will result in fouling or may create carbon build up which can heat up red-hot and cause pre-ignition or detonation.

Fouling

Fouling of the spark plug is indicated by irregular running of the engine, decreased engine speed due to misfiring, reduced performance, and increased fuel consumption. This is due to a loss of compression. Other possible causes are: prolonged idling, or running on a too rich mixture due to a faulty carburetor adjustment or incorrect fuel. The plug face of a fouled spark plug has either a dry coating of soot or an oily, glossy coating given by an excess either of oil or of oil with soot. Such coatings form a conductive connection between the center electrode and ground.

Spark Plug Analysis

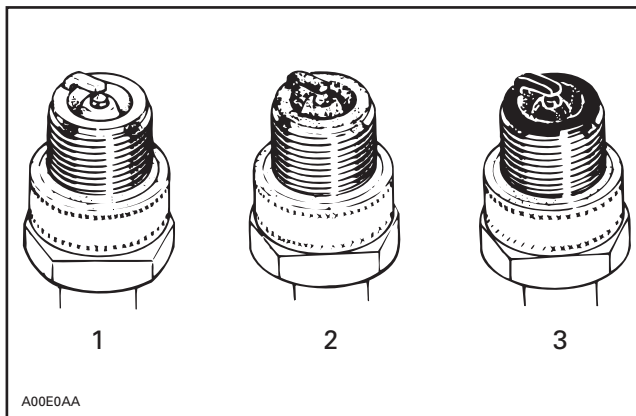

1. Overheated (light grey)
2. Normal (brownish)
3. Fouled (black)

The plug face (and piston dome) reveals the condition of the engine, operating condition, method of driving and fuel mixture. For this reason it is advisable to inspect the spark plug at regular intervals, examining the plug face (i.e. the part of the plug projecting into the combustion chamber) and the piston dome.

Spark Plug Installation

Prior to installation make sure that contact surfaces of the cylinder head and spark plug are free of grime.

1. Using a wire feeler gauge, set electrode gap according to the following chart.

2. Apply anti-seize lubricant over the spark plug threads to prevent possible seizure.
3. Hand screw spark plug into cylinder head and tighten with a torque wrench and a proper socket.

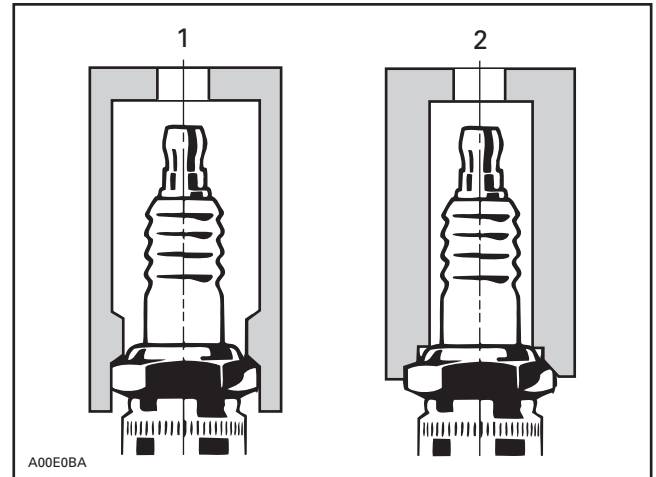

1. Proper socket
2. Improper socket

Spark Plug Chart

Watercraft model	Engine	Spark plug	Torque N•m (lb•ft)	Gap mm (inch)
SP	717D	NGK BR7ES	24 (17)	0.5-0.6 (.020-.024)
GS/GSI/GTS/GTI/HX	717	NGK BR8ES	24 (17)	0.5-0.6 (.020-.024)
SPX/GSX/GTX/XP	787	NGK BR8ES	24 (17)	0.5-0.6 (.020-.024)

NOTE: Refer to next page for **Spark Plug Symbol Explanation**.

Section 07 ELECTRICAL SYSTEM

Sub-Section 02 (IGNITION SYSTEM)

Spark Plug Symbol Explanation

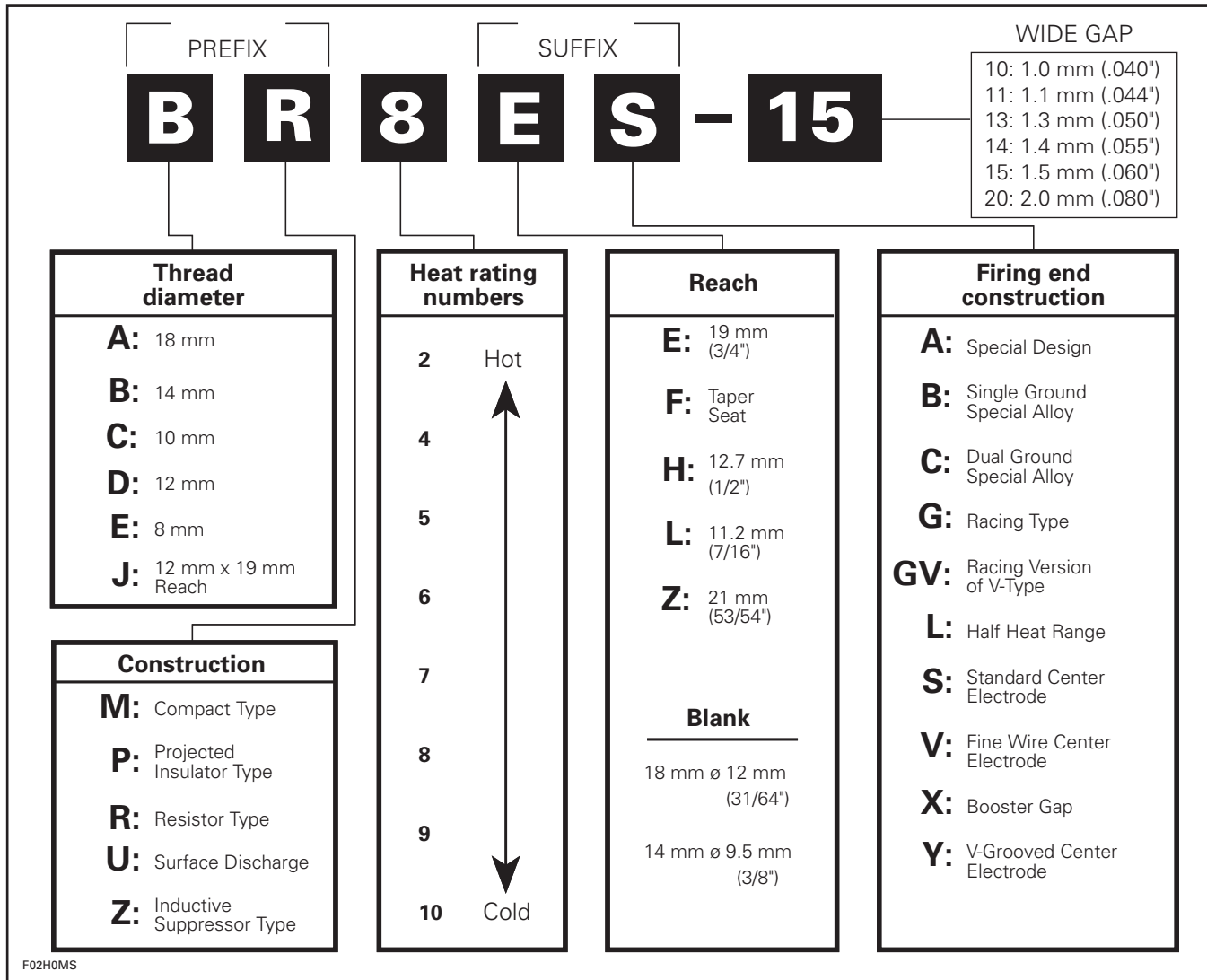

CROSSCUTS AND GAP STYLES OF SPARK PLUGS

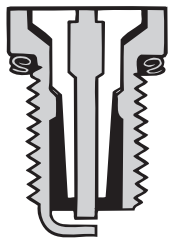

Standard Type

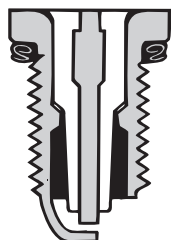

Projected Insulator Type



Taper Seat Type

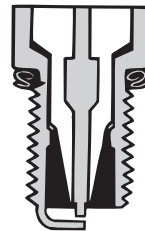

V-Type

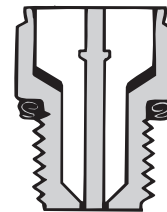

Surface Discharge Type

A01E1PS

CHARGING SYSTEM

GENERAL

Magneto

The purpose of the charging system is to keep the battery at a full state of charge.

The magneto is the primary source of electrical energy. It transforms magnetic field into electric current (AC).

717 Engines

The magneto has a three-pole coil. Capacity is 160 watts.

787 Engine

The magneto has a 3 phase, "Y" wound stator on 18 poles. Capacity is 180 watts.

Rectifier/Regulator

717 Engines

A half-wave rectifier receives magneto AC current and transforms it into direct current (DC) to allow battery charging.

Included in the same unit, a regulator keeps voltage at a steady level (14.5 to 14.8 volts) to prevent any damage to components.

787 Engine

A dual 1/2 wave series rectifier receives the magneto AC current and transforms it into direct current (DC) to allow battery charging.

Included in the same unit, a regulator keeps voltage at a steady level (14.5 to 14.8 volts) to prevent any damage to components.

Battery

The battery is the DC source for the electric starter, the Multi-Purpose Electronic Module and all accessories.

Fuse

SP, GTS and HX Models

A 15 A fuse protects the charging system.

SPX, GS, GSI, GSX, GTI, GTX and XP Models

Two 15 A fuses protect the charging system. The first one is located on the MPEM and the second one is located between the solenoid and the MPEM.

All Models

If the battery is regularly discharged, check fuse condition.

The rectifier/regulator could be the culprit of a blown fuse. To check, simply disconnect the rectifier/regulator from the circuit.

If the fuse still burns, check for a defective wire.



CAUTION

Do not use a higher rated fuse as this cause severe damage.

TESTING PROCEDURE

NOTE: First, ensure that battery is in good condition prior to performing the following tests.

Rectifier/Regulator

STATIC TEST: CONTINUITY

1. Due to internal circuitry, there is no static test available.

DYNAMIC TEST

Current Test

Proceed as follows:

- Start engine.
- Lay an inductive ammeter on positive cable of battery.
- Bring engine to approximately 5500 RPM.

Depending on battery charge, current reading should be approximately 4 amperes for the 717 engines or 5 amperes for the 787 engine. If not, check magneto output prior to concluding that rectifier is faulty.

Voltage Test

Proceed as follows:

- Start engine.
- Connect a DC voltmeter on battery posts.
- Bring engine to approximately 5500 RPM.

Section 07 ELECTRICAL SYSTEM

Sub-Section 03 (CHARGING SYSTEM)

If voltmeter reads over 15 volts, regulator is defective. Replace it.

NOTE: If it is continually necessary to add distilled water to the battery, this indicates an over voltage situation, requiring replacement of the rectifier/regulator. If, on the other hand, the battery will not stay charged, the problem can be any of the charging circuit components. If these all check good, you would be accurate in assuming the problem to be in the rectifier/regulator.

Battery Charging Coil

717 Engines

STATIC TEST: CONTINUITY

1. Disconnect the magneto wiring harness connector.
2. Install the four-pin magneto harness adapter (P/N 295 000 131).
3. Check resistance between the YELLOW and YELLOW/BLACK wires of the magneto harness adapter. Refer to the following table.

PART NAME	ADAPTER WIRE COLOR	RESISTANCE (Ω)
Battery charging coil	YELLOW with YELLOW/BLACK	0.05-0.6

NOTE: A short circuit will read 0 ohm (or close to) on ohmmeter.

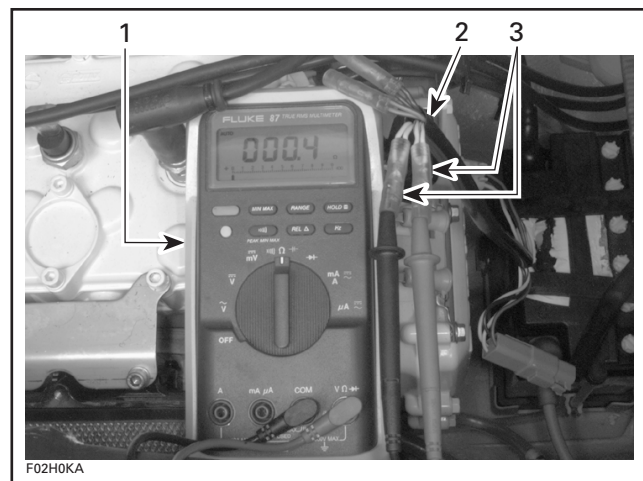

1. Multimeter
2. Magneto harness adapter
3. YELLOW and YELLOW/BLACK wires

DYNAMIC TEST

1. Disconnect the magneto wiring harness connector.
2. Install the four-pin magneto harness adapter (P/N 295 000 131).
3. Connect and set Bombardier Ignition Tester as per following table.

Tester wires	Adapter wire color	Tester switch position	Tester dial position
N	YELLOW	LOW	70
P	YELLOW/BLACK		

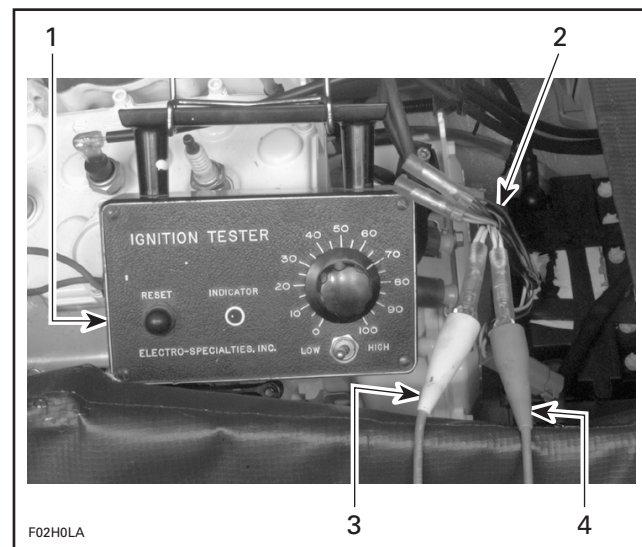

1. Bombardier Ignition tester
2. Magneto harness adapter
3. Probe "N" to YELLOW wire
4. Probe "P" to YELLOW/BLACK wire

4. Crank engine and observe indicator.
5. Push reset button and repeat test twice.

Results:

- Indicator lamp lights:** Battery charging coil output is up to specifications.
- Indicator lamp does not light:** Battery charging coil is faulty. Replace it.

787 Engine

Stator

STATIC TEST: CONTINUITY

1. Disconnect the magneto wiring harness connector.
2. Install the six-pin magneto harness adapter (P/N 295 000 136).
3. Check resistance between two of the YELLOW wires. The resistance should be between 0.1 to 1.0 ohm.

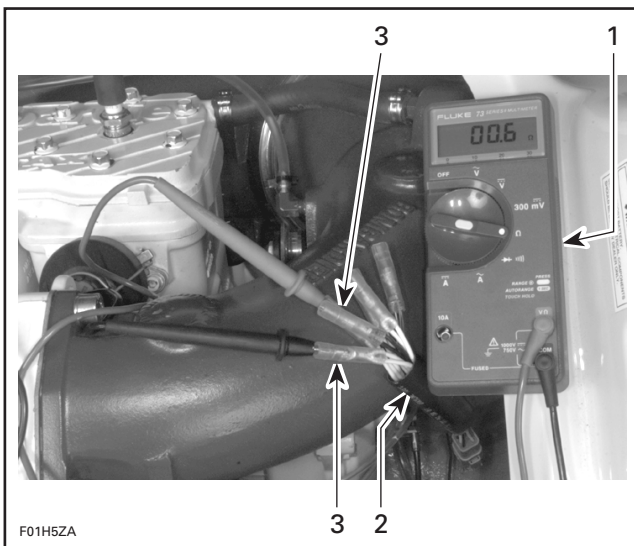

1. Multimeter
2. Magneto harness adapter
3. YELLOW wires

4. Place either meter lead into the remaining YELLOW wire and note the resistance (same as step no. 3). If the readings are out of specification, the stator will need to be replaced.

STATIC TEST: INSULATION

1. Disconnect the magneto wiring harness connector.
2. Install the six-pin magneto harness adapter (P/N 295 000 136).
3. Insert multimeter + lead to one of the YELLOW wire of the six-pin magneto harness adapter.
4. Ground the multimeter – lead to the engine or the stator iron core and note the reading.

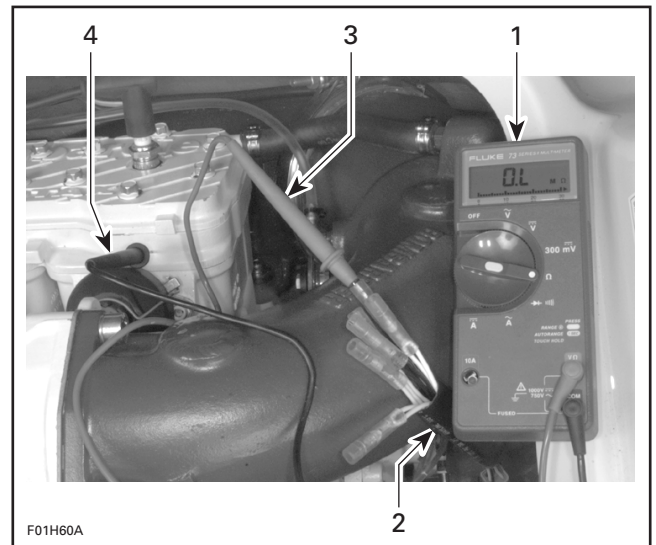

1. Multimeter
2. Magneto harness adapter
3. + lead to YELLOW wire
4. – lead to ground

5. Repeat test with the other two YELLOW wires of the six-pin magneto harness adapter.

NOTE: There should be no continuity (infinity) between the stator insulated coils and ground. If there is a reading, the stator coils and/or the wiring from the coils is grounded and needs to be replaced or repaired.

Section 07 ELECTRICAL SYSTEM
Sub-Section 03 (CHARGING SYSTEM)

BATTERY

Troubleshooting

SYMPTOM: DISCHARGED OR WEAK BATTERY	
CAUSE	REMEDY
1. Battery posts and/or cable terminal oxidized.	Clean and coat with dielectric grease.
2. Loose or bad connections.	Check wiring and connector cleanliness, damaged or short circuit.
3. Faulty battery (sulfated, doesn't keep a full charge, damaged casing, loose post).	Replace.
4. 15 amp fuse(s) burnt or faulty rectifier.	First check fuse. If it is in good condition, check rectifier/regulator.
5. Faulty battery charging coil (or stator).	Replace.

Removal

◆ WARNING
Battery BLACK negative cable must always be disconnected first and connected last. Never charge or boost battery while installed in watercraft.

Proceed as follows:

1. Disconnect the **BLACK** negative cable first.
2. Disconnect the **RED** positive cable last.
3. Remove the vent line from the battery.
4. Remove the holding strap(s).
5. Withdraw battery from watercraft being careful not lean it so that electrolyte flows out of vent elbow.

◆ WARNING
Electrolyte is poisonous and dangerous. Avoid contact with eyes, skin and clothing. Wear a suitable pair of non-absorbent gloves when removing the battery by hand.

▼ CAUTION
Should any electrolyte spillage occur, immediately wash off with a solution of baking soda and water.

Cleaning

Clean the battery casing, caps, cables and battery posts using a solution of baking soda and water.

▼ CAUTION
Do not allow cleaning solution to enter battery.

Remove corrosion from battery cable terminals and battery posts using a firm wire brush. Rinse with clear water and dry well.

Inspection

Visually inspect battery casing for cracks or other possible damage. If casing is damaged, replace battery and thoroughly clean battery tray and close area with water and baking soda.

Inspect battery posts for security of mounting.

Inspect for cracked or damaged battery caps, replace defective caps.

◆ WARNING
Battery caps do not have vent holes. Make sure that vent line is not obstructed.

Electrolyte Level

Check electrolyte level in each cell, add distilled water up to upper level line.

▼ CAUTION
Add only distilled water in an activated battery.

Hydrometer Test

A hydrometer measures the charge of a battery in terms of specific gravity of the electrolyte. Most hydrometers give a true reading at 21°C (70°F).

Section 07 ELECTRICAL SYSTEM
Sub-Section 03 (CHARGING SYSTEM)

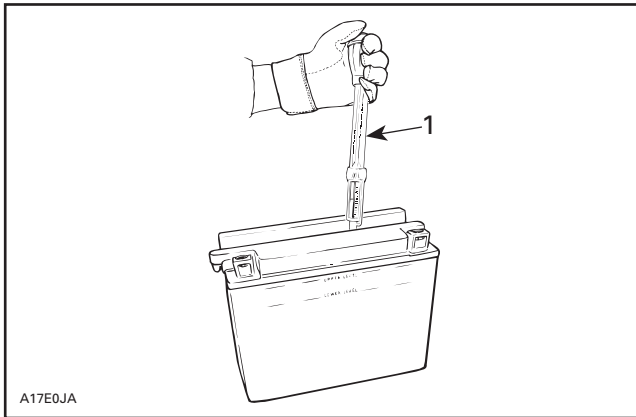

1. Specific gravity 1.260

In order to obtain correct readings, adjust the initial reading by **adding** .004 points to the hydrometer readings for each 5.5°C (10°F) **above** 21°C (70°F) and by **subtracting** .004 point for every 5.5°C (10°F) **below** 21°C (70°F).

This chart will be useful to find the correct reading.

ELECTROLYTE TEMPERATURE		OPERATION TO PERFORM	
°C	°F		
38	100	.012	Add to the reading
32	90	.008	
27	80	.004	
21	70	correct reading	
16	60	.004	Subtract from the reading
10	50	.008	
4	40	.012	
-1	30	.016	

EXAMPLE NO. 1

Temperature above 21°C (70°F):
 Hydrometer reading: 1.250
 Electrolyte temperature: -1°C (30°F)
 Subtract .016 Sp. Gr.
 Corrected Sp. Gr. is 1.234

EXAMPLE NO. 2

Temperature above 21°C (70°F):
 Hydrometer reading: 1.235
 Electrolyte temperature: 38°C (100°F)
 Add .012 Sp. Gr.
 Corrected Sp. Gr. is 1.247

Battery Storage

Disconnect and remove battery from watercraft as explained in **Removal**.

Check electrolyte level in each cell, add distilled water up to upper level line.

▼ CAUTION

Do not overfill.

The battery must always be stored in fully charged condition. If required, charge until specific gravity of 1.260 is obtained.

▼ CAUTION

Battery electrolyte temperature must not exceed 50°C (122°F). The casing should not feel hot.

Clean battery terminals and cable connections using a wire brush. Apply a light coat of dielectric grease on terminals.

Clean battery casing and caps using a solution of baking soda and water.

▼ CAUTION

Do not allow cleaning solution to enter battery.

Rinse battery with clear water and dry well using a clean cloth.

Store battery on a wooden shelf in a cool dry place. Such conditions reduce self-discharging and keep fluid evaporation to a minimum. Keep battery away from dew, high moisture and direct sunlight.

During the storage period, recheck electrolyte level and specific gravity readings at least every month. If necessary, keep the battery at its upper level line and near full charge as possible (trickle charge).

Activation of a New Battery

◆ WARNING

Never charge or boost battery while installed in watercraft.

A new battery is factory fresh dry charged. For storage purposes, it is fitted with a temporary sealing tube.

▼ CAUTION

Do not remove the sealing tube or loosen battery caps unless activation is desired.

NOTE: In case of accidental premature removal of caps or sealing tube, battery should be given a full charge.

Section 07 ELECTRICAL SYSTEM

Sub-Section 03 (CHARGING SYSTEM)

Perform the following operations anytime a new battery is to be installed.

1. Remove the sealing tube from the vent elbow.

◆ WARNING

Failure to remove the sealing tube could result in an explosion.

2. Remove caps and fill battery to UPPER LEVEL line with electrolyte (specific gravity: 1.260 at 21°C (70°F)).

NOTE: This battery may fill slower than others due to the anti-spill check ball design.

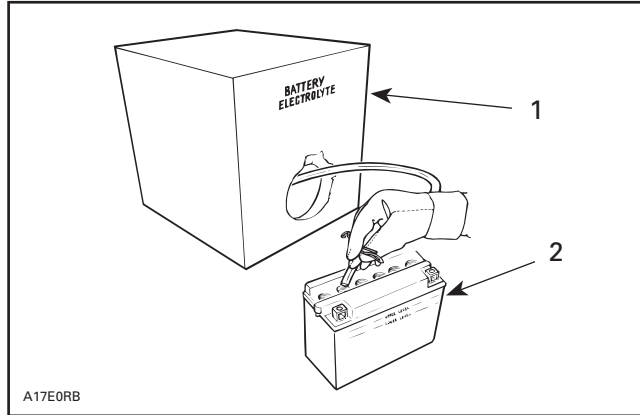

1. Battery electrolyte
2. Upper level line

5. Connect a 2 A battery charger for 3 to 5 hours.

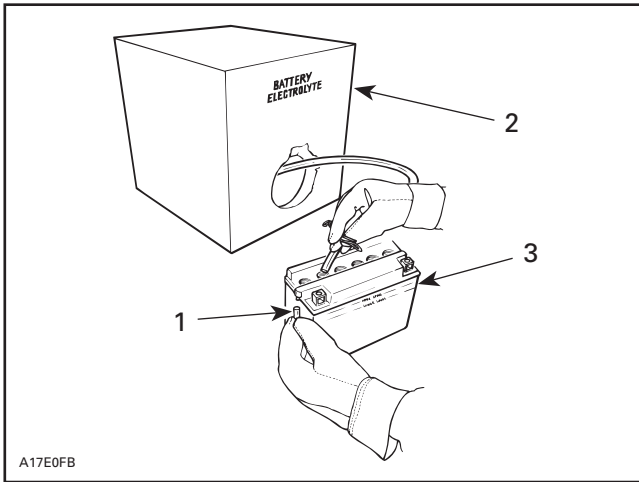

1. Sealing tube removed
2. Battery electrolyte
3. Upper level line

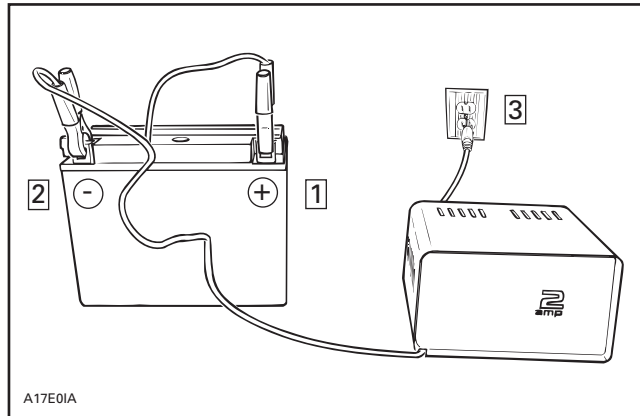

- Step **1**: Connect + lead to battery + post
 Step **2**: Connect - lead to battery - post
 Step **3**: Plug battery charger

3. Allow the battery to stand for 30 minutes MINIMUM so that electrolyte soak through battery cells.

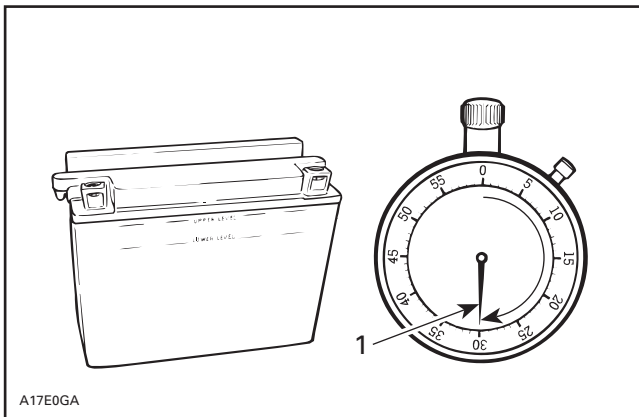

1. 30 minutes

4. Readjust the electrolyte level to the UPPER LEVEL line.

▼ CAUTION

If charging rate raises higher than 2.4 A reduce it immediately. If cell temperature rises higher than 50°C (122°F) or if the casing feels hot, discontinue charging temporarily or reduce the charging rate.

◆ WARNING

Always charge in a well ventilated area. Always turn battery charger off prior to disconnecting cables.

6. Disconnect battery charger.

Section 07 ELECTRICAL SYSTEM

Sub-Section 03 (CHARGING SYSTEM)

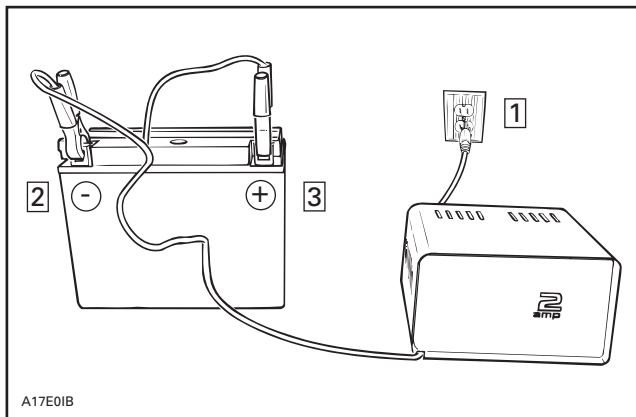

Step **1** : Unplug battery charger
Step **2** : Disconnect - lead
Step **3** : Disconnect + lead

7. Test battery state of charge. Use a hydrometer.

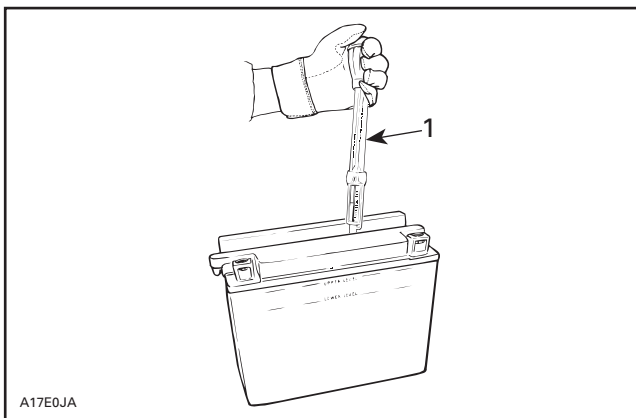

1. Specific gravity 1.260

8. If electrolyte level has dropped after charging, fill with distilled water to UPPER LEVEL line. After water is added, continue charging for 1 to 2 hours to mix water with electrolyte.
9. Reinstall caps and clean any electrolyte spillage using a solution of baking soda and water.

Charging a used battery

◆ WARNING

Never charge battery while installed in watercraft.

For best results, battery should be charged when the electrolyte and the plates are at room temperature. A battery that is cold may not accept current for several hours after charging begun.

Do not charge a frozen battery. If the battery charge is very low, the battery may freeze. If it is suspected to be frozen, keep it in a heated area for about 2 hours before charging.

◆ WARNING

Always charge battery in a well ventilated area.

The time required to charge a battery will vary depending on some factors such as:

- Battery temperature: The charging time is increased as the temperature goes down. The current accepted by a cold battery will remain low. As the battery warms up, it will accept a higher rate of charge.
- State of charge: Because the electrolyte is nearly pure water in a completely discharged battery, it cannot accept current as well as electrolyte. This is the reason the battery will not accept current when the charging cycle first begins. As the battery remains on the charger, the current from the charger causes the electrolytic acid content to rise which makes the electrolyte a better conductor and then, the battery will accept a higher charging rate.
- Type of charger: Battery chargers vary in the amount of voltage and current that they can supply. Therefore, the time required for the battery to begin accepting measurable current will also vary.

Charging a very flat or completely discharged battery

The battery charger should have an adjustable charging rate. Variable adjustment is preferred, but a unit which can be adjusted in small increments is acceptable.

The battery charger must be equipped with an ammeter capable of accurately measuring current of less than 1 ampere.

Unless this procedure is properly followed, a good battery may be needlessly replaced.

Section 07 ELECTRICAL SYSTEM

Sub-Section 03 (CHARGING SYSTEM)

- Measure the voltage at the battery posts with an accurate voltmeter. If it is below 10 volts, the battery will accept current at very low rate, in term of milliamperes, because electrolyte is nearly pure water as explained above. It could be some time before the charging rate increases. Such low current flow may not be detectable on some charger ammeters and the battery will seem not to accept any charge.
- Exceptionally for this particular case, set the charger to a high rate.

NOTE: Some chargers have a polarity protection feature which prevents charging unless the charger leads are connected to the correct battery terminals. A completely discharged battery may not have enough voltage to activate this circuitry, even though the leads are connected properly. This will make it appear that the battery will not accept a charge. Follow the charger manufacturer's instruction on how to bypass or override this circuitry so that the charger will turn on and charge a low-voltage battery.

- Since the battery chargers vary in the amount of voltage and current they provide, the time required for the battery to accept measurable charger current might be up to approximately 10 hours or more.
- If the charging current is not up to a measurable amount at the end of about 10 hours, the battery should be replaced.
- If the charging current is measurable before the end or at the end of about 10 hours, the battery is good and charging should be completed in the normal manner as specified in **Activation of a new battery**.
- It is recommended that any battery recharged by this procedure be load tested prior to returning it to service.

Charging Two or More Batteries at a Time

Connect all positive battery posts together and use a charger with a capacity (rated) equal to: number of battery to be charged multiply by 2 A.

For example: Charging 5 batteries at a time requires a 10 A rated charger ($5 \times 2 \text{ A} = 10 \text{ A}$).

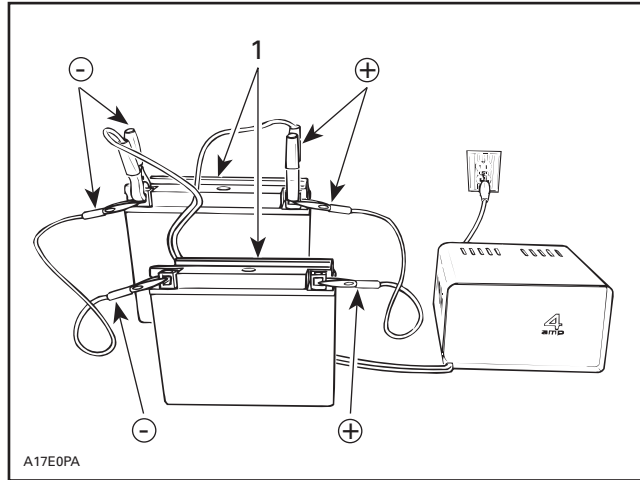

TYPICAL

1. Two batteries = 4 A

WARNING

Always charge battery(ies) in a well ventilated area.

Battery Installation

WARNING

Always connect battery cables exactly in the specified order, RED positive cable first BLACK negative cable last.

Proceed as follows:

1. Install battery in its emplacement.
2. Secure vent line to the battery and support. Ensure vent line is not kinked or obstructed.

WARNING

Vent line must be free and open. Avoid skin contact with electrolyte.

3. First connect RED positive cable.
4. Connect BLACK negative cable last.

NOTE: On the SPX, GSX and GTX models, secure the negative battery cable on top of the small ground wire without using a washer.

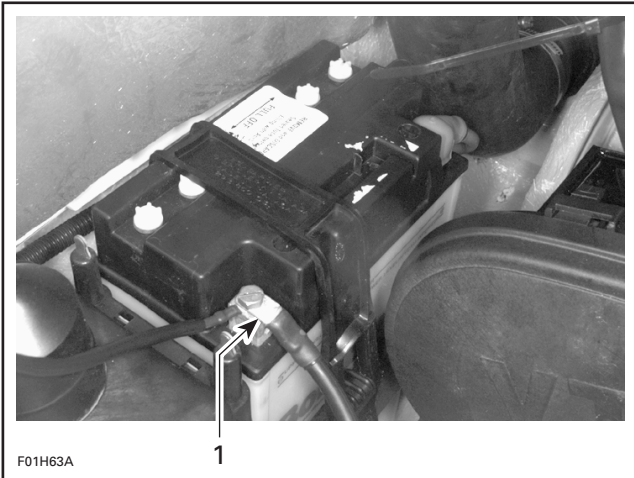

SPX, GSX AND GTX MODELS

1. Negative battery cable on top of small ground wire

5. Apply dielectric grease on battery posts.
6. Verify cable routing and attachment.

SP and GTS Models

Secure RED positive battery cable using right strap of battery.

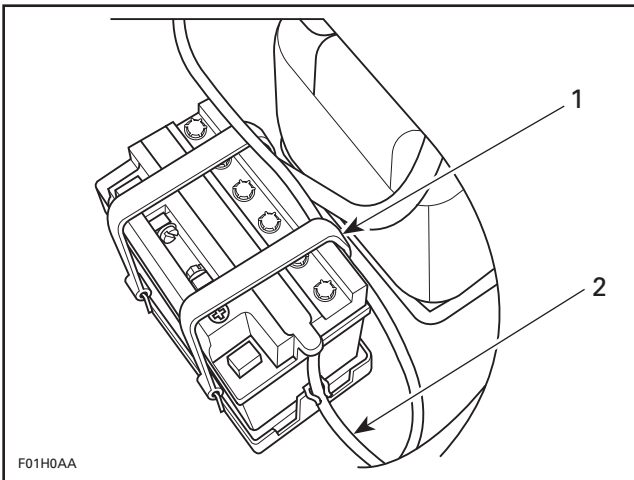

1. Strap retaining RED positive cable
2. Vent tube connected and secured in support

STARTING SYSTEM

717 Engines

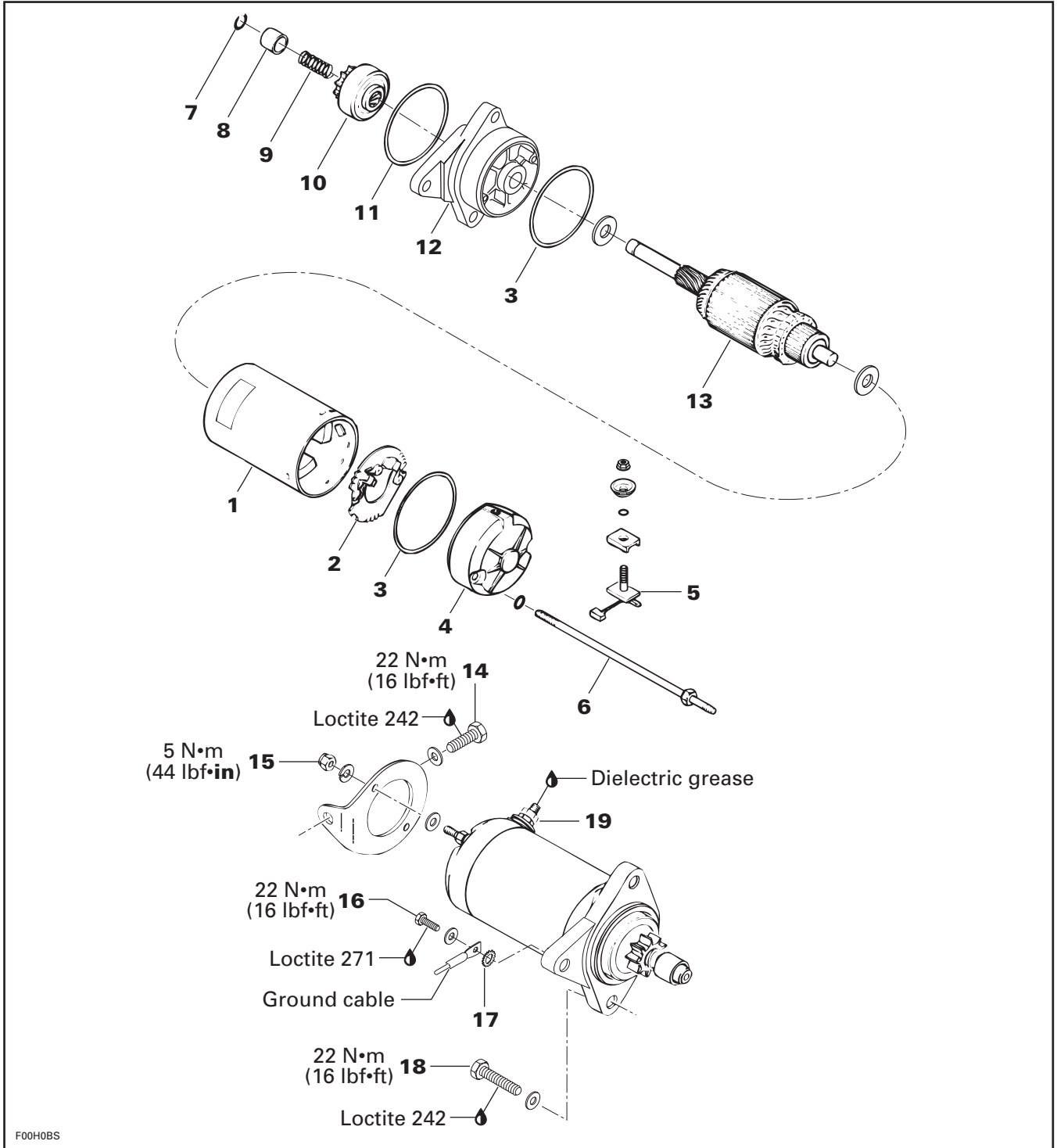

Section 07 ELECTRICAL SYSTEM

Sub-Section 04 (STARTING SYSTEM)

787 Engine

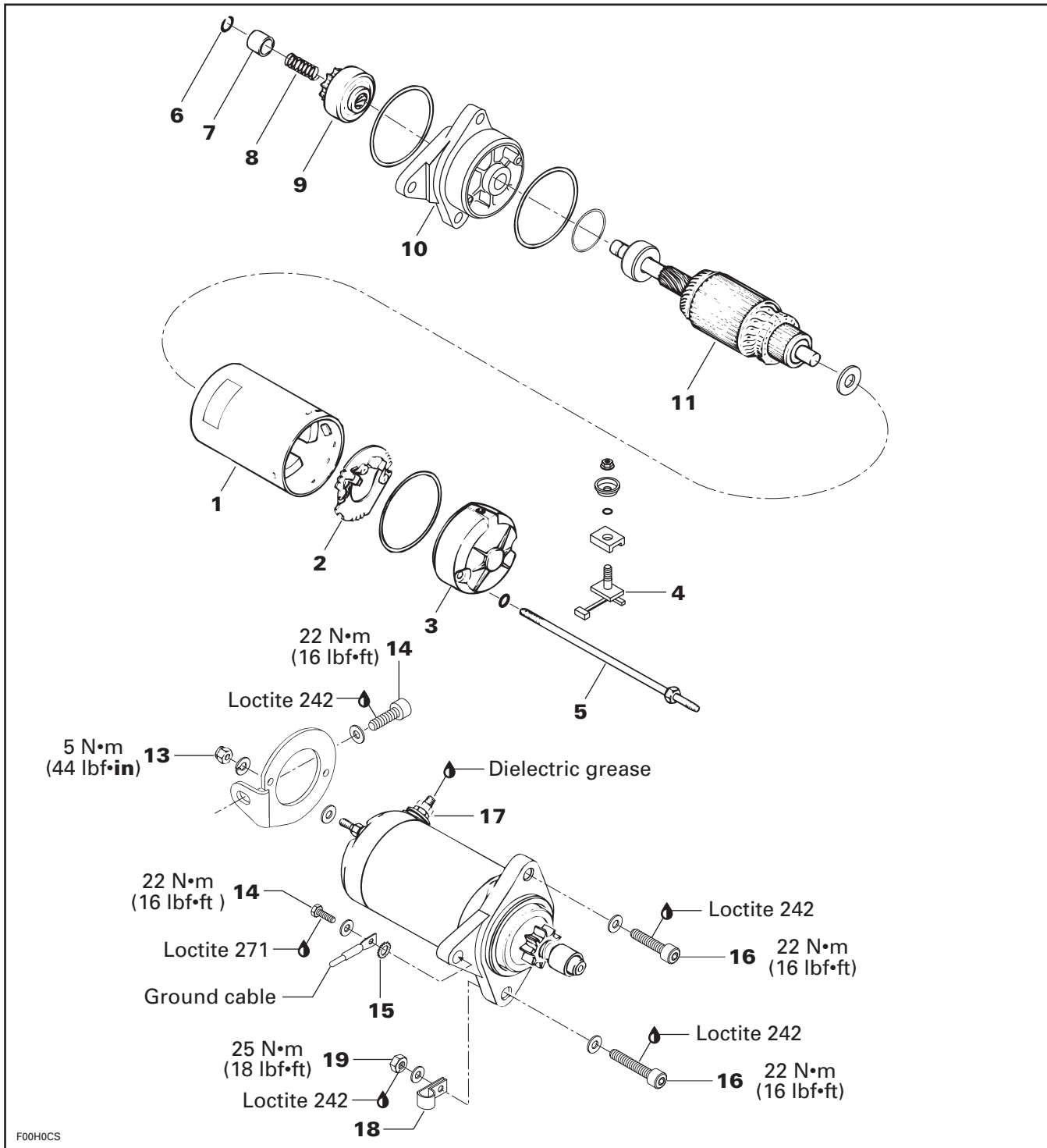

GENERAL

Causes of troubles are not necessarily related to starter but may be due to a burnt fuse, faulty battery, start/stop switch, safety lanyard switch, MPEM, solenoid, electrical cables or connections.

Check these components before removing starter. Consult also the starting system troubleshooting table on next page for a general view of possible problems.

WARNING

Short circuiting electric starter is always a danger, therefore disconnect the battery ground cable before carrying out any kind of maintenance on starting system. Do not place tools on battery.

Fuse

Make sure 5 A fuse on MPEM is in good condition.

The solenoid may be the cause of a burnt fuse. If the solenoid checks good, one of the accessory may be defective.

Battery

To check battery condition, refer to ELECTRICAL SYSTEM 07-04.

MPEM

If 2 short beeps are not heard when installing the safety lanyard, refer to ELECTRICAL SYSTEM 07-06.

Engine Start/Stop Switch

Switch condition can be checked with an ohmmeter.

Disconnect the switch YELLOW/RED wire. Connect test probes to YELLOW/RED wire and to ground near solenoid.

Measure resistance, it must be an open circuit (switch is normally open). Depress and hold switch, the ohmmeter should read close to 0 ohm.

Safety Lanyard Switch

The following continuity tests can be performed using an ohmmeter:

Disconnect switch wires.

Safety Lanyard Removed

Connect test probes to switch BLACK and BLACK/YELLOW wires. Measure resistance, there should be no continuity (open circuit).

Connect one test probe to the WHITE/GRAY wire and the other test probe to the switch terminal. Measure resistance, it must be close to 0 ohm.

Connect one test probe to the BLACK wire and the other test probe to the switch ring. Measure resistance, it must be close to 0 ohm.

Safety Lanyard on Switch

Connect test probes to switch BLACK and BLACK/YELLOW wires. Measure resistance, it must be close to 0 ohm.

Solenoid

NOTE: Solenoid is located in the electrical box. Inspect connections and clean as necessary.

Static Test: Continuity

With a multimeter, check primary winding resistance. It should be approximately 5 ohms.

There should be no continuity between the positive posts of the solenoid.

Dynamic Test

Depress start/stop button and measure the voltage on the solenoid positive posts with a multimeter.

If there is no voltage and battery is in good condition, replace the solenoid.

Electrical Cables or Connections

Check all connections, cables and wires. Tighten any loose cables. Replace any chafe wires.

Section 07 ELECTRICAL SYSTEM

Sub-Section 04 (STARTING SYSTEM)

STARTING SYSTEM TROUBLESHOOTING

SYMPTOM	CAUSE	REMEDY
Starter does not turn.	Burnt 5A fuse. Poor contact of battery terminal(s). Poor battery ground cable connection. Weak battery. Poor contact of start/stop switch, safety lanyard switch or solenoid. Open circuit: start/stop switch or solenoid. Safety lanyard or MPEM.	Check wiring condition and replace fuse. Clean and tighten terminal(s). Clean and tighten. Recharge or replace battery. Replace. Replace. Refer to ELECTRICAL SYSTEM 07-06.
Starter engages; but does not crank the engine.	Poor contact of brush. Burnt commutator. Worn commutator segments. Shorted armature. Weak brush spring tension. Weak magnet. Worn bushings. Weak battery.	Straighten commutator and brush. Turn commutator in lathe. Undercut mica. Repair or replace armature. Replace brush holder or spring. Replace yoke assembly. Replace clutch. Recharge or replace battery.
Starter engages; but does not crank the engine.	Worn clutch pinion gear. Defective clutch. Poor movement of clutch on splines. Worn clutch bushing. Worn ring gear.	Replace clutch. Replace clutch. Clean and correct. Replace clutch. Replace ring gear.
Starter motor keeps running.	Shorted solenoid winding. Melted solenoid contacts. Sticking or defective starter clutch. Presence of salt water in the electrical box which gives continuity.	Replace solenoid. Replace solenoid. Lubricate or replace. Verify electrical box watertightness.

STARTER REMOVAL

Disconnect BLACK cable ground connection from battery.

◆ WARNING

Always disconnect ground cable first and re-connect last.

Disconnect RED cable connection from battery.

Remove the following parts:

- cables from starter
- screw of starter rear support
- starter mount screws

STARTER DISASSEMBLY

Before disassembling, trace index marks on yoke no. 1 and clutch housing no. 10 to ease further assembly.

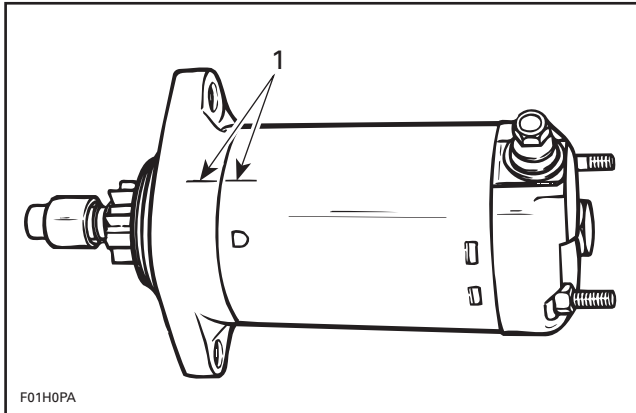

TYPICAL

1. Trace indexing marks

Remove starter support nuts no. 13 then through bolts no. 5. Separate end frame no. 3 from yoke assembly no. 1. Withdraw yoke assembly from armature no. 11.

Brush holder no. 2 can be removed from end frame no. 3 by unscrewing nut retaining terminal.

Check that the radial play between the armature shaft and end frame is not greater than 0.20 mm (.008 in). Replace end frame if so.

Tap the pinion stop collar no. 7 using a screwdriver. Remove circlip no. 6. Disassemble pinion stop collar no. 7 and spring no. 8.

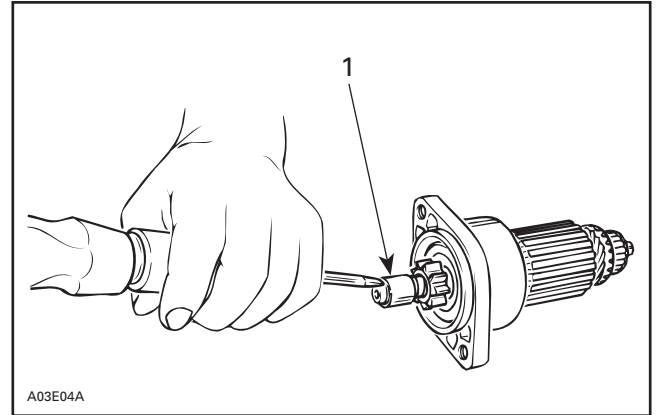

1. Pinion stop collar

Turn clutch assembly no. 9 clockwise to remove it from armature assembly no. 11.

Pull housing from armature.

CLEANING

▼ CAUTION

Yoke ass'y and drive unit assembly must not be immersed in cleaning solvent.

Discard all O-rings.

Clean brushes and holders with a clean cloth soaked in solvent. Brushes must be dried thoroughly with a clean cloth.

Blow brush holders clean using compressed air.

◆ WARNING

Always wear safety glasses when using compressed air.

Remove dirt, oil or grease from commutator using a clean cloth soaked in suitable solvent. Dry well using a clean, dry cloth.

Clean engine ring gear teeth and drive unit (clutch).

NOTE: Bushings (717 engines) or bearings (787 engine) must not be cleaned with grease dissolving agents.

Immerse all metal components in cleaning solution. Dry using a clean, dry cloth.

Section 07 ELECTRICAL SYSTEM

Sub-Section 04 (STARTING SYSTEM)

PARTS INSPECTION

11, Armature

NOTE: An ohmmeter may be used for the following testing procedures, except for the one concerning shorted windings in armature.

Check commutator for roughness, burnt or scored surface. If necessary, turn commutator on a lathe, enough to resurface only.

Check commutator for mica depth. If depth is less than 0.20 mm (.008 in), undercut mica. Be sure that no burrs are left and no copper dust remains between segments after undercutting operation is completed.

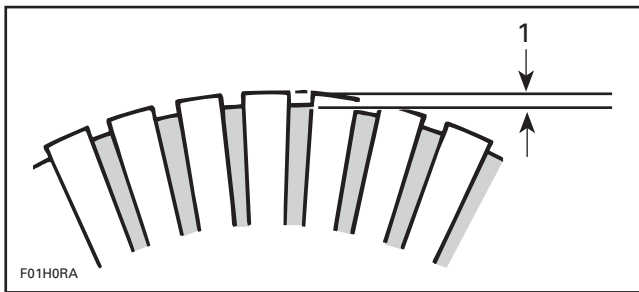

1. Commutator undercut 0.20 mm (.008 in)

Check commutator out of round condition with V-shaped blocks and an indicator. If commutator out of round is more than 0.40 mm (.016 in), commutator should be turned on a lathe.

Check commutator outer diameter. If less than 27 mm (1.063 in), replace.

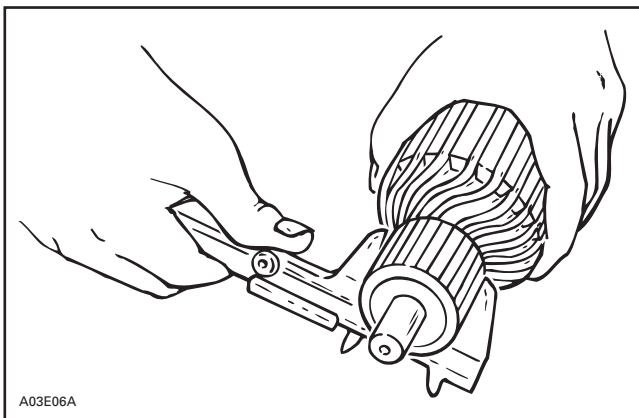

2, Brush Holder

Check brush holder for insulation using an ohmmeter. Place one test probe on insulated brush holder and the other test probe on brush holder plate. If continuity is found, brush holder has to be repaired or replaced.

4, Brush

Measure brush length. If less than 8.5 mm (.335 in), replace them.

NOTE: New brush length is 12 mm (.472 in).

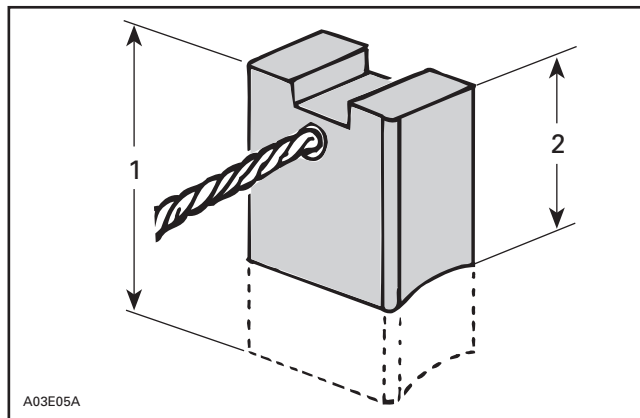

1. New
2. Wear limit, 8.5 mm (.335 in)

9, Overrunning Clutch

Pinion of overrunning clutch should turn smoothly in clockwise direction, and should not slip in a counterclockwise direction. If defective, replace.

Check pinion teeth for wear and damage. If defective, replace.

NOTE: Always check engine ring gear teeth for wear and damage. If defective replace ring gear. Refer to ELECTRICAL SYSTEM 07-02.

STARTER ASSEMBLY

Reverse the order of disassembly to reassemble starter. However, attention should be paid to the following operations.

Prior to assembling, coat sliding surfaces on armature shaft splines, overrunning clutch and bushing (717 engines) with G.E. Versilube G 341 M or ESSO Beacon 325 lubricant or equivalent.

After placing pinion stop collar no. 7 on armature shaft no. 11, fit circlip no. 6 into armature shaft, then make sure that it is properly secured.

Slide stop collar **no. 7** over circlip **no. 6** and secure in place by punching it at 2 or 3 places.

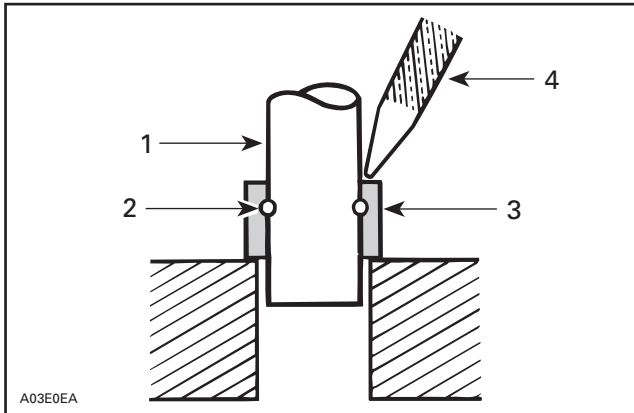

1. Armature shaft
2. Circlip
3. Pinion stop collar
4. Punch

1,10, Yoke Assembly and Clutch Housing

Align previously traced indexing marks.

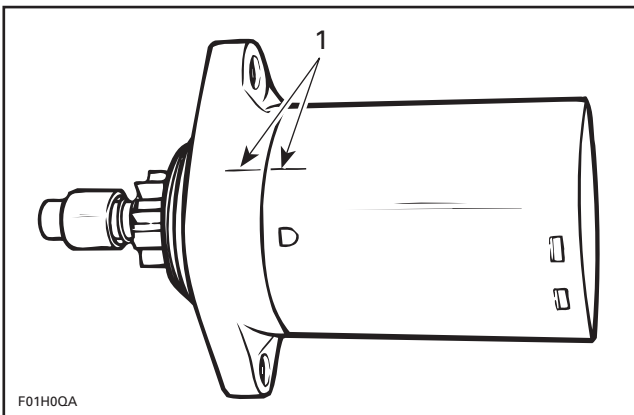

TYPICAL

1. Align marks

Open brushes **no. 4** and slide over commutator. Align end frame locating notch with yoke locating protrusion and properly sit brush holder **no. 2** into yoke **no. 1**.

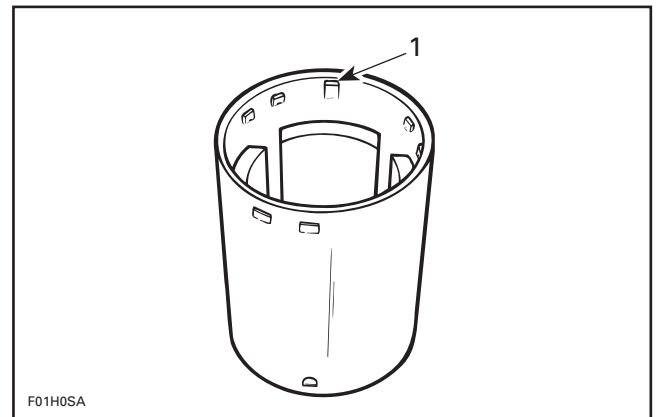

1. Locating protrusion is the higher one

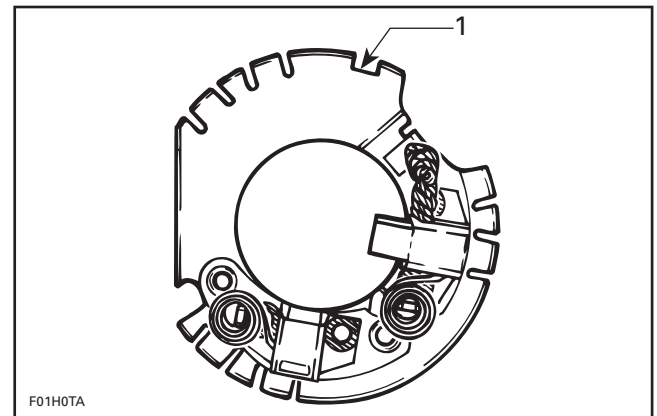

1. Brush holder locating notch

To ease end frame installation, retain brush holder with a small screwdriver while installing end frame.

Section 07 ELECTRICAL SYSTEM

Sub-Section 04 (STARTING SYSTEM)

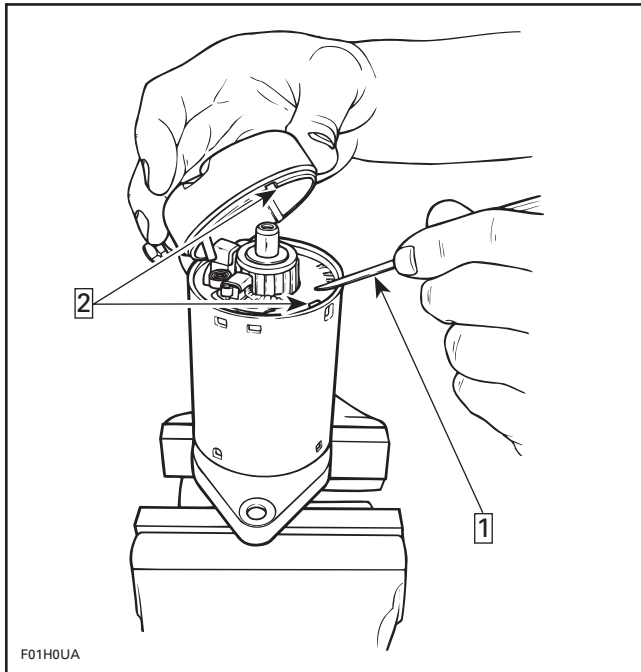

Step 1: Retaining brush holder with a screwdriver

Step 2: Align here

Align end frame notch with brush holder notch/yoke protrusion.



CAUTION

Make sure end frame fits perfectly on yoke.

STARTER INSTALLATION

Installation is essentially the reverse of removal procedure. However, pay particular attention to the following.

Make sure that starter and engine mating surfaces are free of debris. Serious trouble may arise if starter is not properly aligned.

12,16, Screw

Apply Loctite 242 (blue) on threads and torque starter screws to 22 N•m (16 lbf•ft).

17, Nut

Connect the RED battery cable to the starter and torque nut to 6 N•m (53 lbf•in). Apply dielectric grease on terminal and nut.

14,15, Screw and Teeth Washer

Apply Loctite 271 (red) on screw.

Connect BLACK cable to starter using flat washer, teeth washer and screw. Torque screw to 22 N•m (16 lbf•ft). Apply dielectric grease on terminal and screw.

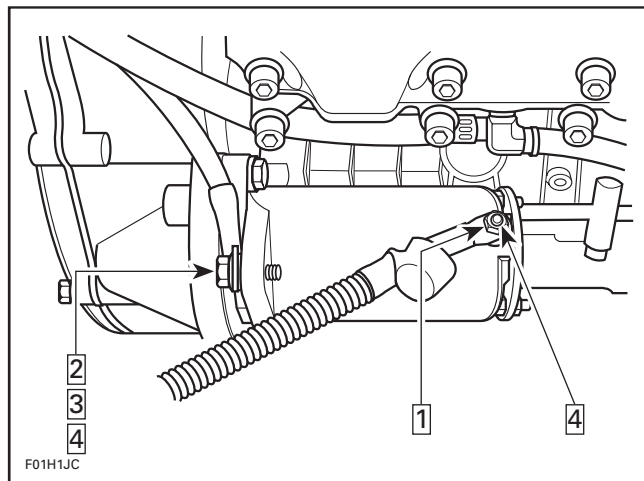

717 ENGINE SHOWN

Step 1: Torque nut to 6 N•m (53 lbf•in)

Step 2: Apply Loctite 271 on screw

Step 3: Torque screw to 22 N•m (16 lbf•ft)

Step 4: Apply dielectric grease



WARNING

Always connect RED positive cable first then BLACK negative cable last. Whenever connecting the RED positive cable to the starter motor make sure the battery cables are disconnected to prevent electric shock.

787 Engine Only

18, Locking Collar

Install the locking collar of the fuel hose. Apply Loctite 242 (blue) on nut no. 19 and torque to 25 N•m (18 lbf•ft).

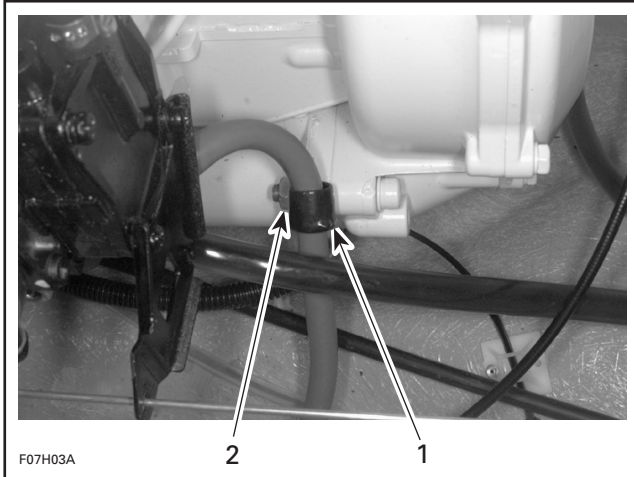

- 1. Locking collar
- 2. Nut

STARTER SPECIFICATION

Nominal output	0.6 kW		
Voltage	12 V		
Rated time	30 seconds		
Rotation	Counterclockwise (viewed from pinion side)		
Weight	Approx. 2 kg (4.4 lb)		
Performance specification at 20 °C (68 °F)	No load	11.5 V	20 A max. 5500 RPM
	Load	8.5 V	170 A max. 2200 RPM
	Stall	5 V	350 A max. 0 RPM
Battery	19 Ah		

INSTRUMENTS AND ACCESSORIES

GENERAL

It is possible to activate the instruments when the engine is not running.

Make sure the safety lanyard is removed, then depress the start/stop button.

The timer of the MPEM will maintain the gauge(s) activated during a period of approximately 33 seconds.

INSPECTION

Exterior Temperature Sensor

GTX Model

The temperature sensor is located in the storage cover.

Remove the back panel of the storage cover to access the temperature sensor.

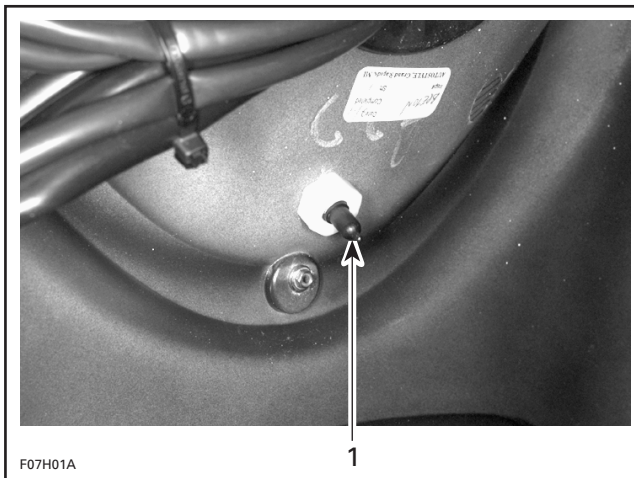

1. Temperature sensor

To check if the temperature sensor is operational, activate the Info Center and select the exterior temperature mode.

Use a heat gun to warm up the sensor. The temperature should raise rapidly on the gauge.

If not, replace the temperature sensor.

Lake Temperature Sensor

GTX Model

The lake temperature sensor is integrated with the speed sensor located on the ride plate.

To check if the lake temperature sensor is operational, activate the Info Center and select the lake temperature mode.

With a garden hose, spray the speed sensor with water. The lake temperature on the Info Center should adjust to the water temperature.

If not, replace the speed sensor.

Compass

GTX Model

The compass is located in the storage cover.

Remove the back panel of the storage cover to access the compass.

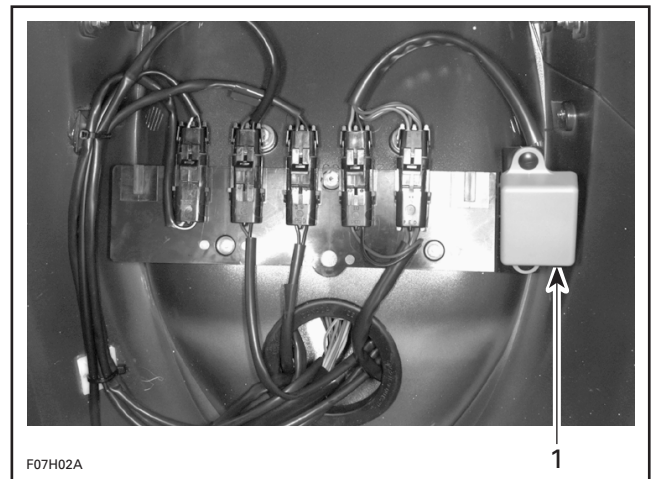

1. Compass

Remove the compass from the support.

Activate the Info Center.

Change the direction of the compass and keep it horizontal ($\pm 10^\circ$). There should be a change of direction on the Info Center.

NOTE: To check the accuracy of the compass, you can use a portable compass and point it in the same direction. Compare the given directions, they should be the same.

Section 07 ELECTRICAL SYSTEM

Sub-Section 05 (INSTRUMENTS AND ACCESSORIES)

Tachometer

GTX Model

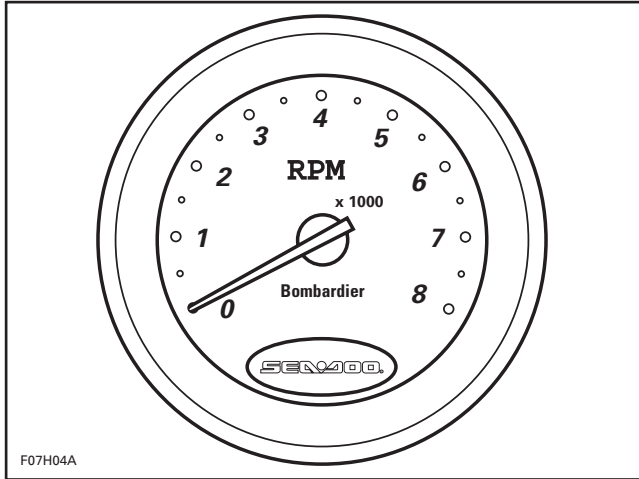

The PURPLE wire is the 12 VDC power source of the tachometer.

The BLACK wire is the ground.

The GRAY wire is the pulse signal from the multi-purpose electronic module (MPEM).

Speed Sensor

GSX, GTI and GTX Models

The speedometer gives a reading through a speed sensor. Speed sensor is installed on riding plate. It works with the water flow which turns a magnetic paddle wheel that triggers an electronic pick-up that in turn sends a speed signal to the speedometer.

The paddle wheel is protected by the pick-up housing.

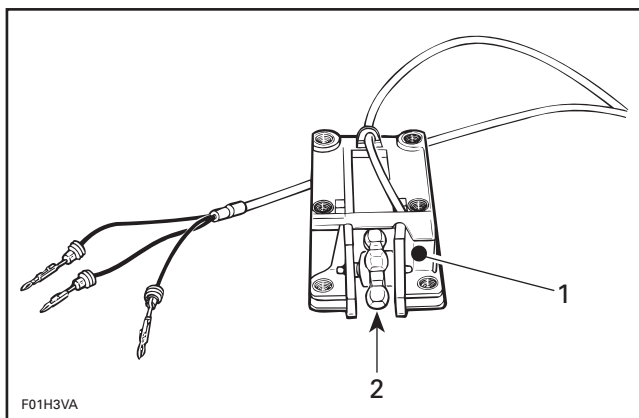

1. Pick-up housing
2. Paddle wheel

To check if the speed sensor is operational, disconnect the speed sensor connector housing from inside bilge.

Using an appropriate terminal remover (Snap-on TT600-4), remove the PURPLE/YELLOW and BLACK/ORANGE wires from the tab housing of the speed sensor.

Reconnect the PURPLE/YELLOW and BLACK/ORANGE wires in the receptacle housing.

Connect the positive probe of a voltmeter to speed sensor PURPLE/YELLOW wire and the negative probe to speed sensor BLACK/ORANGE wire.

Depress the start/stop button to activate the timer.

Spin the paddle wheel. There should be a voltage fluctuation.

Speedometer

GSX, GTI and GTX Models

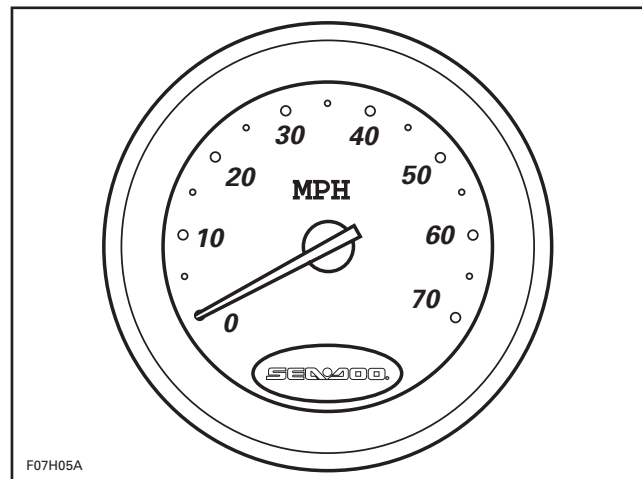

The PURPLE wire is the 12 VDC power source of the speedometer.

The BLACK wire is the ground.

The PURPLE/YELLOW wire is the pulse signal from the speed sensor.

Info Center

GSI, GSX and GTX Models

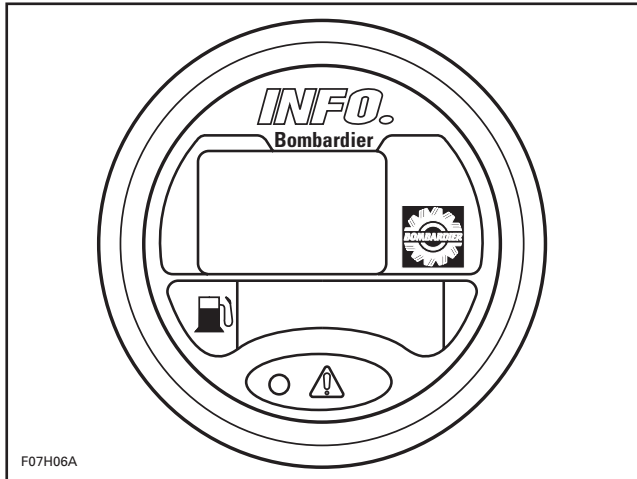

This is a LCD multifunction gauge. It features the following functions:

- fuel level
- low fuel level
- low oil level
- low voltage
- overheating
- hourmeter
- clock
- maintenance information
- chronometer
- tachometer
- speedometer (GSX and GTX models)
- peak speed (GSX and GTX models)
- average speed (GSX and GTX models)
- trip meter (GSX and GTX models)
- VTS (GSI and GSX models)
- compass (GTX model)
- exterior temperature (GTX model)
- lake temperature (GTX model)

The Info Center also features a red warning LED which turns on if a particular condition such as low fuel, low oil, low voltage or overheating occur.

As a self test, all LCD segments and the LED will turn on for 3 seconds each time the watercraft is started.

Operation

SCROLLING FUNCTIONS

Press the MODE button until the desired function is displayed on the Info Center.

RESET

To reset a function such as the chronometer, peak speed, trip meter, etc., select the desired function using the MODE button then press and hold the SET button for 2 seconds.

DISPLAY PRIORITIES

The clock (and compass for the GTX) is the basic mode of the Info Center.

The chronometer, tachometer and speedometer (if applicable) are the only other functions that may be chosen to replace the clock mode.

If an another function is chosen, the clock mode will be displayed again after 4 seconds.

In the event of a warning message such as low fuel is displayed, the message will blink and override any other functions.

If more than one warning message is displayed, the messages will blink and reappear every 4 seconds.

LANGUAGE OPTION

While in the clock mode, press and hold the SET button for 2 seconds. Language option will be displayed.

Press the MODE button to scroll language (English, French and Spanish).

Press the SET button to confirm the selected language and return to the clock mode.

ENGLISH/METRIC OPTION

Press and hold both MODE and SET buttons for 2 seconds. The system will be automatically changed.

CHRONOMETER

Select the chronometer mode and press the SET button to start or stop the chronometer.

Press the SET button for 2 seconds to reset the chronometer.

CLOCK SETTING

While in the clock mode, press and hold both MODE and SET buttons for 2 seconds. The clock will blink to confirm the setting mode.

Section 07 ELECTRICAL SYSTEM

Sub-Section 05 (INSTRUMENTS AND ACCESSORIES)

Press the MODE button to adjust the hours and the SET button to adjust the minutes.

Press again on both the MODE and SET buttons to exit the setting mode (or the gauge will automatically exit the setting mode after 10 seconds).

MAINTENANCE INFORMATION

When the watercraft is due for a maintenance inspection, the message "MAINT" will blink.

To clear the "MAINT" message, press the SET button for 2 seconds during the message blinking.

Verification

The PURPLE wire is the 12 VDC power source of the Info Center.

The BLACK wire is the ground.

The RED/PURPLE wire is the 12 VDC from the battery protected by a 5 A fuse on the MPEM.

The accuracy of some features of the Info Center can be checked with a potentiometer.

FUEL LEVEL

Disconnect the 4-circuit connector housing of the Info Center.

Using an appropriate terminal remover, remove the PINK wire from the tab housing.

Reconnect the connector housing.

Disconnect the 2-circuit connector housing which contains a PURPLE and BLACK wires.

Remove the BLACK wire from the receptacle housing.

Reconnect the connector housing.

Connect potentiometer test probes to the PINK and BLACK wires.

Adjust potentiometer to the resistance values as per following chart to test the accuracy of the gauge.

NOTE: The gauge must be activated to obtain a reading.

RESISTANCE (Ω)	FUEL LEVEL LCD GRAPHIC	LOW FUEL LEVEL RED LIGHT
0 + 2.2	FULL	OFF
17.8 \pm 2.2	7/8	OFF
27.8 \pm 2.2	3/4	OFF
37.8 \pm 2.2	5/8	OFF
47.8 \pm 2.2	1/2	OFF
57.8 \pm 2.2	3/8	OFF
67.8 \pm 2.2	1/4	OFF
77.8 \pm 2.2	1/8	ON
89.0 \pm 2.2	EMPTY	ON

VTS

GSI and GSX Models

Disconnect the 2-circuit connector housing of the Info Center.

Connect potentiometer test probes to the BROWN/WHITE and BROWN/BLACK wires.

Adjust potentiometer to the resistance values as per following chart to test the accuracy of the gauge.

NOTE: The gauge must be activated to obtain a reading.

RESISTANCE (Ω)	VTS LEVEL LCD GRAPHIC
167.3 \pm 2.2	11/11 (UP)
153.0 \pm 2.2	10/11
138.7 \pm 2.2	9/11
124.4 \pm 2.2	8/11
110.1 \pm 2.2	7/11
95.8 \pm 2.2	6/11
81.5 \pm 2.2	5/11
67.2 \pm 2.2	4/11
52.9 \pm 2.2	3/11
38.6 \pm 2.2	2/11
24.3 \pm 2.2	1/11 (DOWN)

Section 07 ELECTRICAL SYSTEM
Sub-Section 05 (INSTRUMENTS AND ACCESSORIES)

LAKE TEMPERATURE

Disconnect the 2-circuit connector housing of the Info Center which contains a BLACK/ORANGE and TAN/ORANGE wires.

Connect potentiometer test probes to the BLACK/ORANGE and TAN/ORANGE wires.

Adjust potentiometer to the resistance values as per following chart to test the accuracy of the gauge.

NOTE: The gauge must be activated to obtain a reading.

RESISTANCE (Ω)	DISPLAY TEMPERATURE (°C)
25407.3	5 ± 2
19911.1	10 ± 2
15718.0	15 ± 2
12495.0	20 ± 2
10000.0	25 ± 2
8054.9	30 ± 2
6528.3	35 ± 2

RESISTANCE (Ω)	DISPLAY TEMPERATURE (°F)
22799.0	45 ± 4
17262.0	55 ± 4
13470.0	65 ± 4
10496.3	75 ± 4
8264.4	85 ± 4
6528.3	95 ± 4

EXTERIOR TEMPERATURE

Disconnect the 2-circuit connector housing of the Info Center which contains a TAN/WHITE and BLACK/WHITE wires.

Connect potentiometer test probes to the TAN/WHITE and BLACK/WHITE wires.

Adjust potentiometer to the resistance values as per following chart to test the accuracy of the gauge.

NOTE: The gauge must be activated to obtain a reading.

RESISTANCE (Ω)	DISPLAY TEMPERATURE (°C)
25590.1	5 ± 2
20005.8	10 ± 2
15761.7	15 ± 2
12510.2	20 ± 2
10000.0	25 ± 2
8047.8	30 ± 2
6518.7	35 ± 2

RESISTANCE (Ω)	DISPLAY TEMPERATURE (°F)
22919.8	45 ± 4
17491.7	55 ± 4
13487.5	65 ± 4
10501.5	75 ± 4
8252.0	85 ± 4
6518.7	95 ± 4

Fuel Gauge/Low Oil Warning Light

SPX, GS, GTS, GTI, HX and XP Models

The fuel gauge has a pointer which indicates fuel level in the tank.

The low oil warning light is part of the gauge. It will light when injection oil level is low.

Section 07 ELECTRICAL SYSTEM

Sub-Section 05 (INSTRUMENTS AND ACCESSORIES)

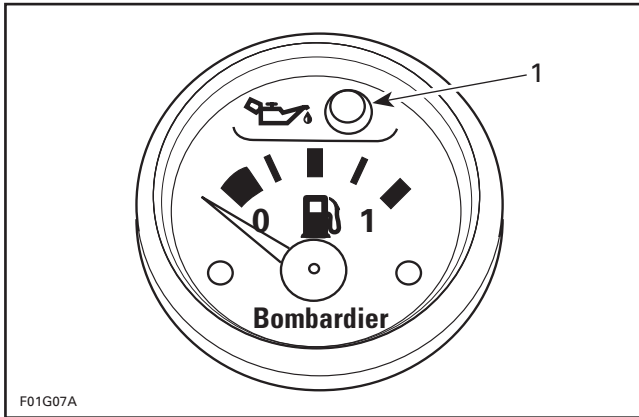

F01G07A

SPX, GTS, HX AND XP MODELS

1. Low oil warning light

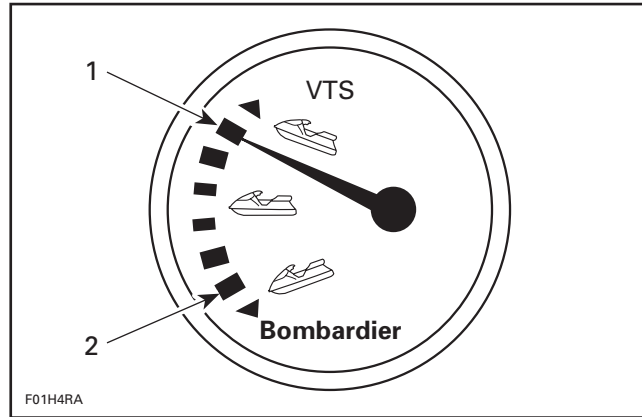

F01H4RA

TYPICAL

1. Bow up
2. Bow down

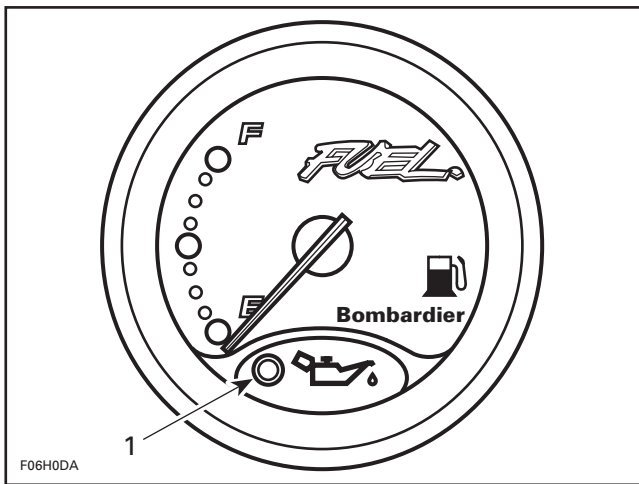

F06H0DA

GS AND GTI MODELS

1. Low oil warning light

Variable Trim Gauge

SPX and XP Models

The trim gauge shows the riding angle of the watercraft.

Accuracy of gauge can be checked with a potentiometer.

- Disconnect 2-circuit connector housing of BROWN/BLACK and BROWN/WHITE wires of gauge.
- Connect potentiometer test probes to BROWN/BLACK and BROWN/WHITE wires of gauge.
- Adjust potentiometer to the resistance values as per following chart to test accuracy of gauge.

NOTE: Gauge must be activated to obtain a reading.

RESISTANCE (Ω)	GAUGE NEEDLE POSITION
10	- 45°
95	0°
180	+ 45°

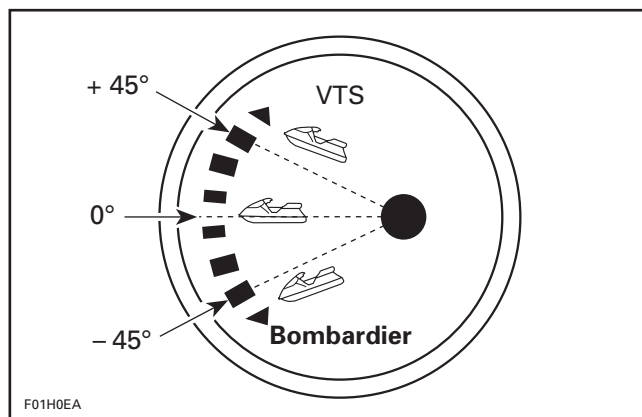

F01H0EA

If gauge is not within the specifications, replace it.

Fuel Baffle Pick-Up Sensor

SPX, GS, GSI, GSX, GTS, GTI, GTX and HX Models

The baffle pick-up has an integrated fuel sensor.

To verify fuel sensor, a resistance test should be performed with an ohmmeter allowing the float to move up through a sequence.

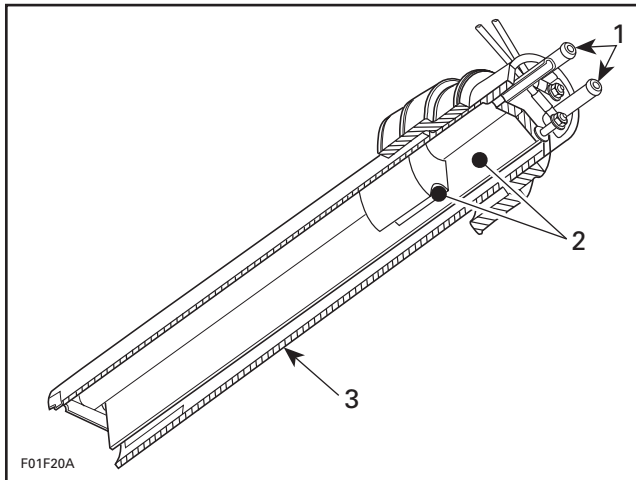

- 1. Pick-up tube
- 2. Fuel sensor
- 3. Baffle pick-up

The resistance measured between PINK/BLACK and PINK wires must be in accordance with fuel level (measured from under the flange) as specified in the following charts.

FUEL LEVEL AND RESISTANCE (SPX)	
FUEL LEVEL (mm)	RESISTANCE (Ω)
From 206.1 ± 5 and more	0 + 2.2
From 189.1 to 206 ± 5	17.8 ± 2.2
From 162.1 to 189 ± 5	27.8 ± 2.2
From 135.1 to 162 ± 5	37.8 ± 2.2
From 108.1 to 135 ± 5	47.8 ± 2.2
From 81.1 to 108 ± 5	57.8 ± 2.2
From 54.1 to 81 ± 5	67.8 ± 2.2
From 40.1 to 54 ± 5	77.8 ± 2.2
From 0 to 40 ± 5	89.8 ± 2.2

FUEL LEVEL AND RESISTANCE (GTS)	
FUEL LEVEL (mm)	RESISTANCE (Ω)
From 257.9 ± 5 and more	0 + 2.2
From 234.4 to 257.8 ± 5	17.8 ± 2.2
From 200.9 to 234.3 ± 5	27.8 ± 2.2
From 167.4 to 200.8 ± 5	37.8 ± 2.2
From 134 to 167.3 ± 5	47.8 ± 2.2
From 100.5 to 133.9 ± 5	57.8 ± 2.2
From 67 to 100.4 ± 5	67.8 ± 2.2
From 40.1 to 66.9 ± 5	77.8 ± 2.2
From 0 to 40 ± 5	89.8 ± 2.2

FUEL LEVEL AND RESISTANCE (GS, GSI, GSX, HX, GTI and GTX)	
FUEL LEVEL (mm)	RESISTANCE (Ω)
From 248.9 ± 5 and more	0 + 2.2
From 234.4 to 248.8 ± 5	17.8 ± 2.2
From 200.9 to 234.3 ± 5	27.8 ± 2.2
From 167.4 to 200.8 ± 5	37.8 ± 2.2
From 134.0 to 167.3 ± 5	47.8 ± 2.2
From 100.5 to 133.9 ± 5	57.8 ± 2.2
From 67.0 to 100.4 ± 5	67.8 ± 2.2
From 40.1 to 66.9 ± 5	77.8 ± 2.2
From 0 to 40.0 ± 5	89.8 ± 2.2

Oil Sensor

All Models Except the SP

The sensor sends the signal to the low-oil level light in the fuel gauge or the LED in the Info Center.

Section 07 ELECTRICAL SYSTEM

Sub-Section 05 (INSTRUMENTS AND ACCESSORIES)

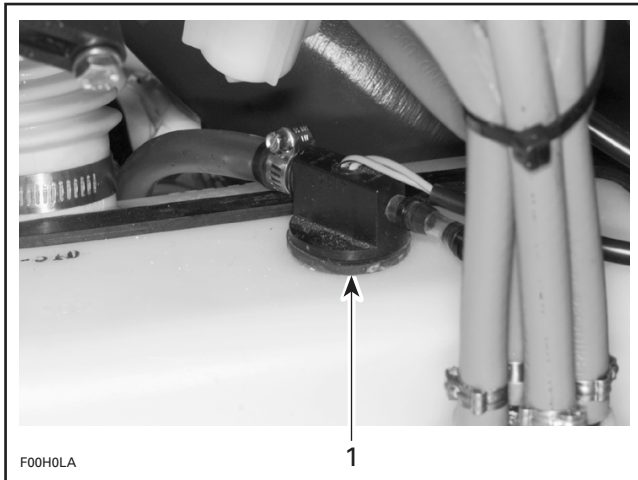

1. Oil sensor

The bottom of the sensor has a small reservoir with two small holes underneath to let the oil enter inside and one at the top to let the air enter allowing the oil to flow out.

When there is enough oil inside the oil tank (and therefore in the sensor reservoir), the sensor detects the liquid and the light DOES NOT turn on.

When the oil level goes at critical LOW level inside the oil tank (and therefore in sensor reservoir), the sensor detects the absence of liquid and the light TURNS ON.

To check the oil sensor, unplug its connector and pull sensor out of oil tank.

Using an ohmmeter, check the continuity between the BLUE and BLUE/BLACK terminals.

When sensor is out of oil tank and its reservoir is empty, resistance must be infinite (open circuit).

NOTE: Wait about 15-20 seconds before taking any reading to give the oil enough time to flow out or inside sensor reservoir.

Soak sensor in oil so that its reservoir fills up. Maximum resistance should be approximately 2 Ω (closed circuit).

TEST CONDITION	READING (Ω)
Sensor OUT of oil.	∞ (open circuit)
Sensor soaked IN oil.	2 Ω max. (closed circuit)

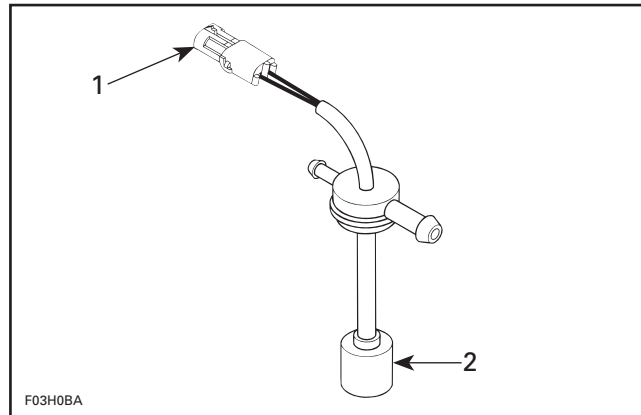

1. Measure resistance here
2. Sensor reservoir

To reinstall sensor:

- Remove rubber seal from sensor.
- Install seal in oil tank hole.
- Push sensor in seal.
- Plug connector.

NOTE: This sensor turns the LED to ON if the connector has been forgotten unconnected even when there is enough oil in tank.

VTS Switch

SPX, GSI, GSX and XP Models

Always confirm first that the fuse is in good condition.

Disconnect BLACK wire, BLUE/WHITE wire and GREEN/WHITE wire of VTS switch.

Using an ohmmeter, connect test probes to switch BLACK and BLUE/WHITE wires; then, connect test probes to switch BLACK and GREEN/WHITE wires.

Measure resistance; in both test it should be high when button is released and must be close to zero when activated.

VTS Motor

SPX, GSI, GSX and XP Models

Always confirm first that the fuse is in good condition.

Motor condition can be checked with an ohmmeter. Install test probes on both BLUE/ORANGE and GREEN/ORANGE wires. Measure resistance, it should be close to 1.5 ohm.

If motor seems to jam and it has not reached the end of its stroke, the following test could be performed.

First remove motor, refer to PROPULSION SYSTEM 08-05. Then manually rotate worm to verify VTS system actuating mechanism for free operation.

Connect motor through a 15 A fuse directly to the battery.

Connect wires one way then reverse polarities to verify motor rotation in both ways.

If VTS actuating mechanism is correct and the motor turns freely in both ways, VTS module could be defective.

VTS Control Module

SPX, GSI, GSX and XP Models

It receives its current from the battery. It is protected by its own 7.5 A fuse.

RESISTANCE TEST

Disconnect BROWN/BLACK wire and BROWN/WHITE wire of VTS control module.

Connect test probes of an ohmmeter to BROWN/BLACK wire and BROWN/WHITE wire of VTS control module.



NOTE: To permit VTS actuation when engine is not running, remove safety lanyard from switch and depress start/stop button to activate timer.

Push on VTS switch down position until motor stops.

Read the resistance on the ohmmeter, it should indicate a resistance of 24 ohms \pm 1%.

Push on VTS switch up position until motor stops.

Read the resistance on the ohmmeter, it should indicate a resistance of 167 ohms \pm 1%.

RESISTANCE (Ω)	NOZZLE POSITION
167 \pm 1%  24 \pm 1%	UP  DOWN

NOTE: If the VTS control module passes this resistance test, it doesn't mean it is in perfect condition.

DIGITALLY ENCODED SECURITY SYSTEM

GENERAL

The Digitally Encoded Security System (DESS) features an anti-start protection against unauthorized use of the watercraft.

The following components are specially designed for this system: Multi-Purpose Electronic Module (MPEM), safety lanyard cap and safety lanyard switch.

The safety lanyard cap has a magnet and a ROM chip. The chip has a unique digital code.

The DESS circuitry in the watercraft MPEM is activated at the factory. Therefore, a safety lanyard must be programmed to start the engine.

NOTE: Actually, it is the memory of the MPEM which is programmed to recognize the digital code of the safety lanyard cap. This is achieved with the MPEM programmer (P/N 295 000 127). Refer to its guide to program a safety lanyard.

The system is quite flexible. Up to eight safety lanyards may be programmed in the memory of the watercraft MPEM. They can also be erased.

NOTE: If desired, a safety lanyard can be used on any watercraft of the same model year equipped with the DESS.

The memory of the MPEM is permanent. If the battery is disconnected, no information is lost.

The memory of the MPEM has also two self-diagnostic modes.

When ordering a new MPEM from the regular parts channel, the DESS circuitry will be activated.

Section 07 ELECTRICAL SYSTEM

Sub-Section 06 (DIGITALLY ENCODED SECURITY SYSTEM)

Basic Self-Diagnostic Mode

It is self-activated when the safety lanyard is being installed on the watercraft switch. It gives immediate monitoring. Some codes may occur only when pressing the start/stop button. Refer to the following chart.

SIGNAL	CAUSE	REMEDY
2 short beeps (while installing safety lanyard on watercraft switch)	<ul style="list-style-type: none">• Safety lanyard is recognized by the MPEM.	<ul style="list-style-type: none">• Ignition is authorized, engine can start.
1 long beep (while installing safety lanyard on watercraft switch or when pressing start/stop button in some cases)	<ul style="list-style-type: none">• Bad connection between safety lanyard cap and switch.• Unprogrammed or defective safety lanyard.• Salt water in safety lanyard cap.• Improper operation of MPEM or defective wiring harness.	<ul style="list-style-type: none">• Remove and replace the safety lanyard on the switch until 2 short beeps are heard to indicate the system is ready to allow engine starting.• Use the safety lanyard that has been programmed for the watercraft. If it does not work, check safety lanyard condition with the programmer. Replace safety lanyard if reported defective. If it still does not work, enable more detail about the failure.• Clean safety lanyard cap to remove salt water.• Enable advanced diagnostic mode to obtain more detail about the failure.
8 short beeps	<ul style="list-style-type: none">• Defective MPEM (memory).	<ul style="list-style-type: none">• Replace MPEM.
Continuous beep	<ul style="list-style-type: none">• Engine overheating.	<ul style="list-style-type: none">• Refer to TROUBLESHOOTING 02-01.

Advanced Self-Diagnostic Mode

It needs to be enabled manually. Proceed as follows:

1. Remove safety lanyard from watercraft switch.
2. Press 5 times on the watercraft start/stop button.

NOTE: 1 short beep and 1 long beep must be heard. They validate beginning of diagnostic mode.

3. Install safety lanyard on watercraft switch.
4. Press the watercraft start/stop button again.

NOTE: If everything is correct, engine will start. Otherwise, refer to the following chart.

SIGNAL	CAUSE	REMEDY
No beep	<ul style="list-style-type: none"> • Engine actually starts. 	<ul style="list-style-type: none"> • Everything is correct.
1 long and 1 short beeps	<ul style="list-style-type: none"> • No safety lanyard has ever been programmed in watercraft MPEM. 	<ul style="list-style-type: none"> • Use programmer and program a safety lanyard. This code can occur only when you receive a new MPEM from the factory and no key has ever been programmed.
2 short beeps	<ul style="list-style-type: none"> • MPEM can not read the digital code of the safety lanyard cap or the magnet is defective. • Mixed wires at safety lanyard switch connectors or bad connections. 	<ul style="list-style-type: none"> • Check safety lanyard cap condition with the MPEM programmer. Replace safety lanyard if reported defective. • Check switch wiring harness.
2 long beeps	<ul style="list-style-type: none"> • Wrong safety lanyard or bad connection of the DESS wires. 	<ul style="list-style-type: none"> • Use the safety lanyard that has been programmed for the watercraft. If the problem is not resolved, check safety lanyard cap condition with the MPEM programmer. Replace safety lanyard if reported defective.
3 short beeps	<ul style="list-style-type: none"> • Wiring harness of DESS switch is grounded or there is a short circuit. 	<ul style="list-style-type: none"> • Check wiring harness and safety lanyard switch.

If you need to listen again the coded beeps, remove safety lanyard and repeat the procedure to activate the diagnostic mode.

If there is more than one problem, the MPEM will send only one error code. When the problem is solved, the MPEM will send a second code and so on until all problems are resolved.

TABLE OF CONTENTS

JET PUMP	08-02-1
GENERAL	08-02-2
JET PUMP INSPECTION ON WATERCRAFT	08-02-2
REMOVAL	08-02-4
DISASSEMBLY	08-02-6
CLEANING	08-02-8
PARTS INSPECTION	08-02-9
ASSEMBLY	08-02-11
PUMP PRESSURIZATION	08-02-18
INSTALLATION	08-02-18

DRIVE SYSTEM	08-03-1
GENERAL	08-03-4
REMOVAL	08-03-4
DISASSEMBLY	08-03-8
PARTS INSPECTION	08-03-8
ASSEMBLY	08-03-9
LUBRICATION	08-03-14

REVERSE SYSTEM	08-04-1
GENERAL	08-04-2
DISASSEMBLY	08-04-2
ASSEMBLY	08-04-3
ADJUSTMENTS	08-04-5
DISASSEMBLY	08-04-8
INSPECTION	08-04-8
ASSEMBLY	08-04-9
ADJUSTMENT	08-04-10

VARIABLE TRIM SYSTEM	08-05-1
MANUAL TRIM	08-05-1
REMOVAL	08-05-2
DISASSEMBLY	08-05-2
ASSEMBLY AND INSTALLATION	08-05-2
ELECTRIC TRIM	08-05-3
GENERAL	08-05-4
REMOVAL	08-05-4
DISASSEMBLY	08-05-4
INSPECTION	08-05-4
ASSEMBLY	08-05-5
INSTALLATION	08-05-5
ADJUSTMENT	08-05-6

JET PUMP

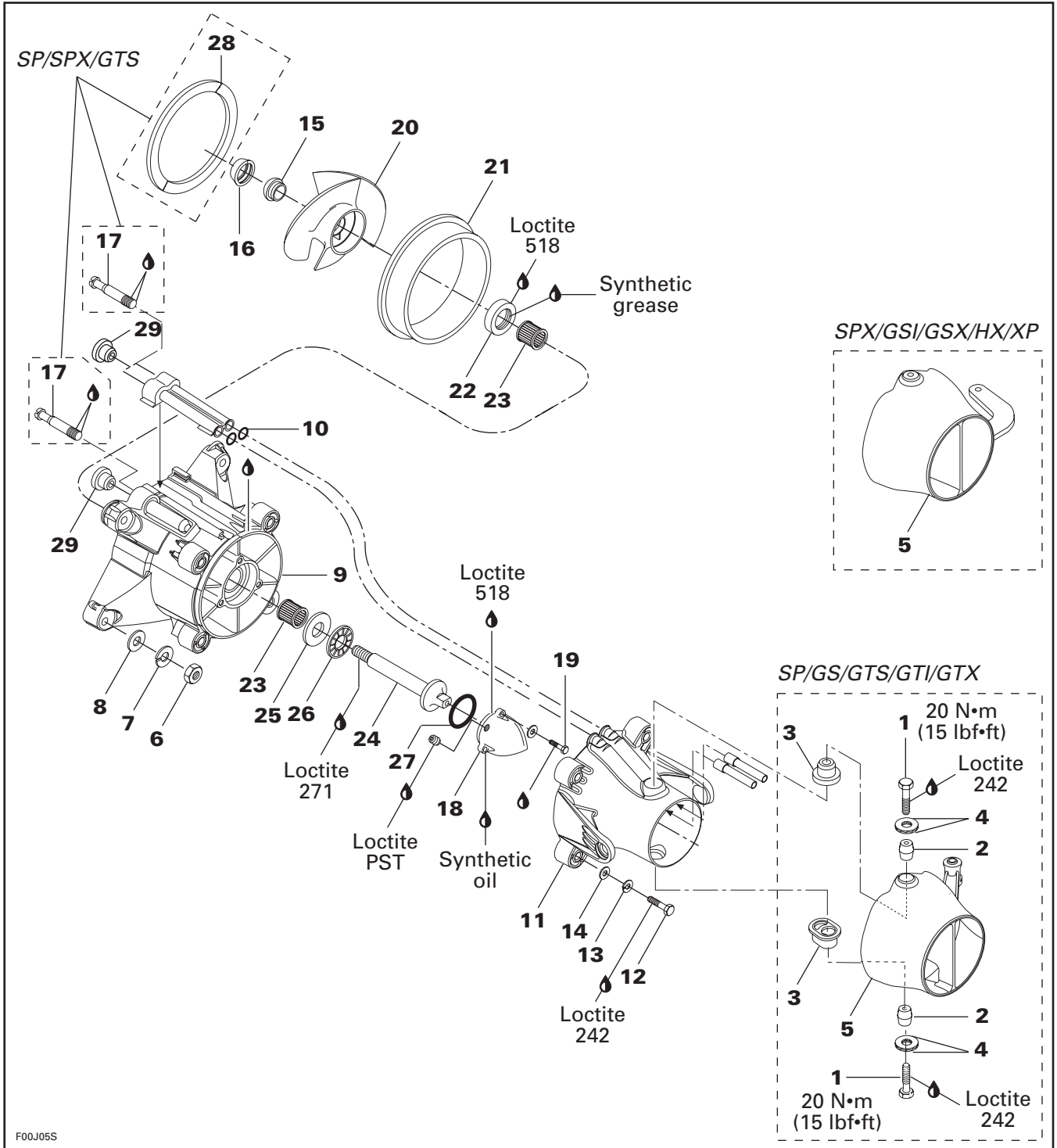

Section 08 PROPULSION SYSTEM

Sub-Section 02 (JET PUMP)

GENERAL

The jet pump housing and venturi are made of plastic.

On the SP, GS and GSI models, the jet pump housing is a one piece plastic unit, including the stator.

On other models, the jet pump housing has a stator made of bronze which offers greater strength.

The nozzle is either made of plastic or aluminum, depending upon the model of watercraft.

Impeller Identification

To identify the impellers refer to the following illustration and chart.

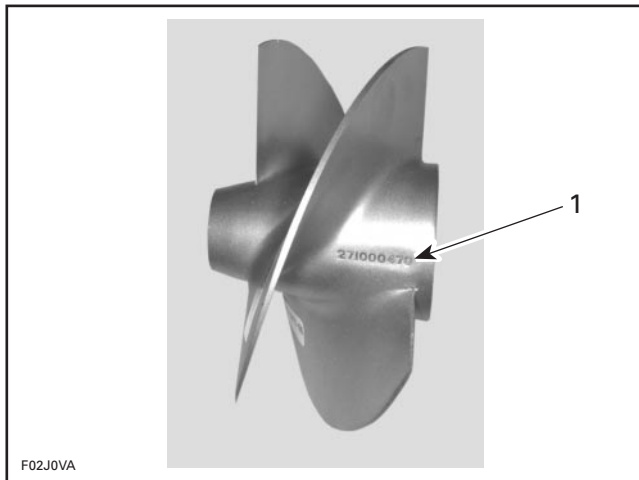

1. Stamped part number

WATERCRAFT MODEL	IMPELLER P/N	MATERIAL	PITCH
SP	271 000 669	Aluminum	Progressive pitch 16°-35°
SPX/GSX/XP	271 000 331	Stainless steel	Progressive pitch 16°-23°
GS/GSI/HX	271 000 497	Stainless steel	Progressive pitch 11°-22°
GTS/GTI	271 000 470	Stainless steel	Progressive pitch 11°-22°
GTX	271 000 660	Stainless steel	Progressive pitch 17°-25°

JET PUMP INSPECTION ON WATERCRAFT

To work on watercraft, securely install it on a stand. Thus, if access is needed to water inlet area, it will be easy to slide underneath watercraft.

A lift kit can be used to install watercraft on a stand. Refer to the following chart.

LIFT KIT P/N	WATERCRAFT MODEL
295 100 012	SP/SPX/GS/GSI/GSX/HX
295 100 013	GTS/GTI/GTX
295 100 044	XP

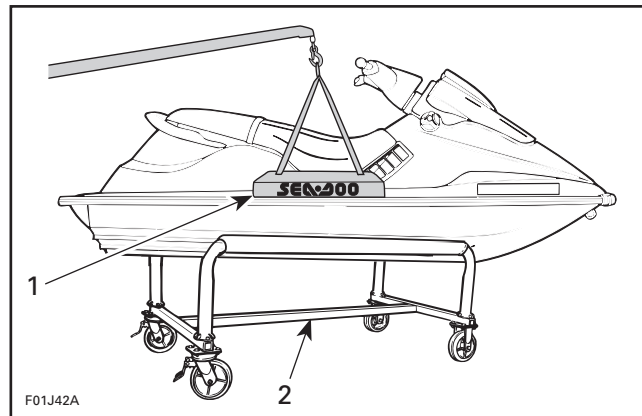

1. Lift kit
2. Work stand

Impeller Condition

Condition of impeller **no. 20**, boot **no. 15** and ring **no. 16** can be quickly checked from underneath of the watercraft. Remove grate and look through water inlet opening.

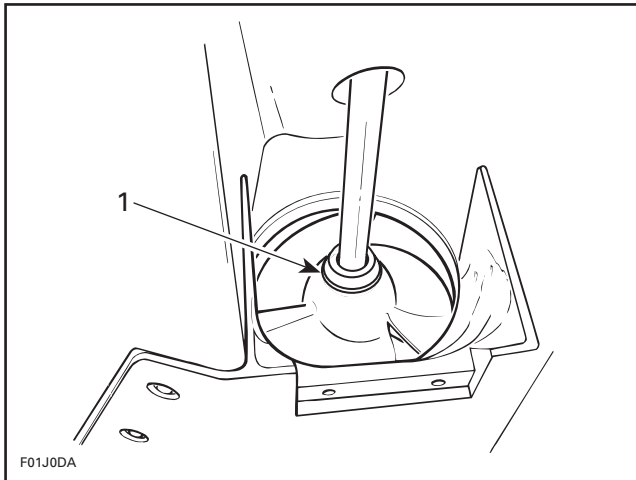

TYPICAL

1. Inspect impeller and boot

Impeller/Wear Ring Clearance

This clearance is critical for jet pump performance.

Clearance can be checked from water inlet opening or from venturi side. However, the last method requires more work.

To check clearance from water inlet side, remove inlet grate.

To check clearance from venturi side, remove venturi/nozzle assembly as described in Oil Inspection in this section.

Using a feeler gauge with 30 cm (12 in) blades, measure clearance between impeller blade tip and wear ring. Measure each blade at its center. Clearance should not exceed 1.0 mm (.040 in). If clearance is greater, disassemble jet pump and inspect impeller and wear ring. Renew worn parts.

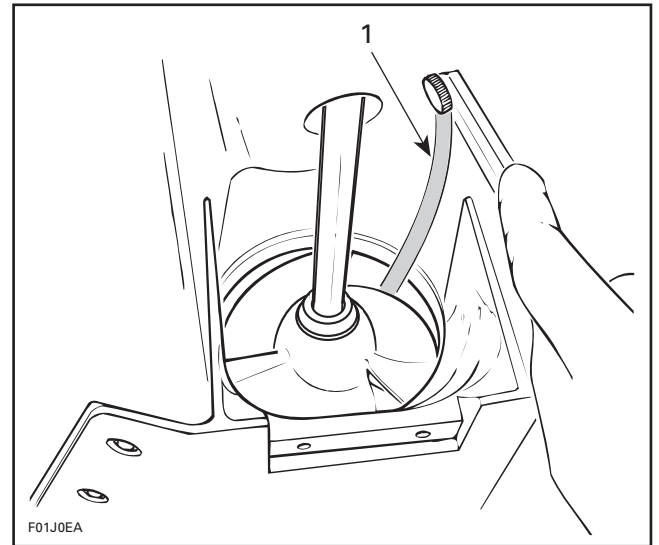

TYPICAL — MEASURING FROM WATER INLET SIDE

1. Feeler gauge

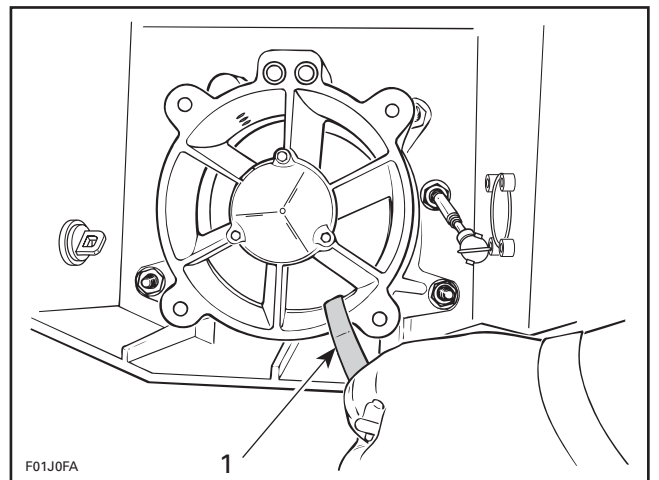

TYPICAL — MEASURING FROM VENTURI SIDE

1. Feeler gauge

Oil Inspection

Detach ball joint of steering cable from nozzle.

SPX, XP, GSI and GSX Models

Detach ball joint of VTS link rod.

GTS, GTI and GTX Models

Detach ball joint of reverse cable and springs from reverse gate (GTS model only).

All Models

Remove 4 screws retaining venturi to jet pump housing.

Section 08 PROPULSION SYSTEM

Sub-Section 02 (JET PUMP)

GTI and GTX Models

Remove reverse gate and support.

All Models

Pull nozzle and venturi from impeller housing.

NOTE: On the GTS model, the venturi and reverse gate are removed as an assembly.

Remove plug from cover.

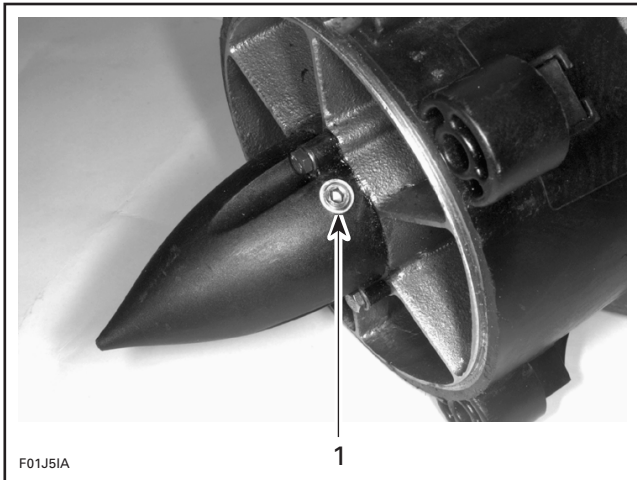

TYPICAL

1. Remove plug

Check oil level, it should be at bottom of hole threads.

If oil level is low, check impeller shaft housing for leaks. A pressure test must be performed. Refer to PUMP PRESSURIZATION in this section.

To check oil condition, insert a wire through oil level hole then withdraw. A whitish oil indicates water contamination.

This may involve defective impeller shaft seal and/or O-ring of housing cover. Jet pump unit should be overhauled to replace seal.

If everything is correct, apply Loctite PST 592 on plug and reinstall it on cover. Properly reinstall removed parts.

Oil Replacement

Remove venturi as described in **Oil Inspection**.

Remove 3 screws retaining cover.

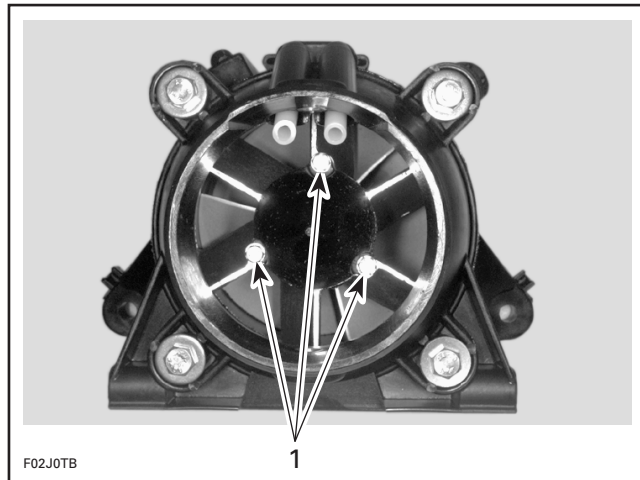

1. Screws

Using a fiber hammer, gently tap cover to release it from housing cover.

Thoroughly clean reservoir and inside of cover with a solvent. Check O-ring condition. Replace as necessary.

Apply a thin layer of Loctite 518 on mating surface of cover and reinstall it with its O-ring. Torque screws to 4 N•m (35 lbf•in).

Remove plug from cover.

Pour approximately 70 mL (2.4 oz) of oil through hole until oil reaches the bottom of hole threads. Use SEA-DOO JET PUMP SYNTHETIC OIL (P/N 293 600 011) only. Oil will drain slowly into center area of housing, wait a few minutes and readjust oil level.

CAUTION

This is a synthetic oil. Do not mix with mineral based oil. Do not mix oil brands.

Apply Loctite PST 592 on plug and reinstall it on cover.

Properly reinstall removed parts.

REMOVAL

5, Nozzle

Disconnect steering cable from jet pump nozzle.

SP, GS, GTS, GTI and GTX Models

Remove 2 retaining screws no. 1, 2 sleeves no. 2, 4 locking disks no. 4.

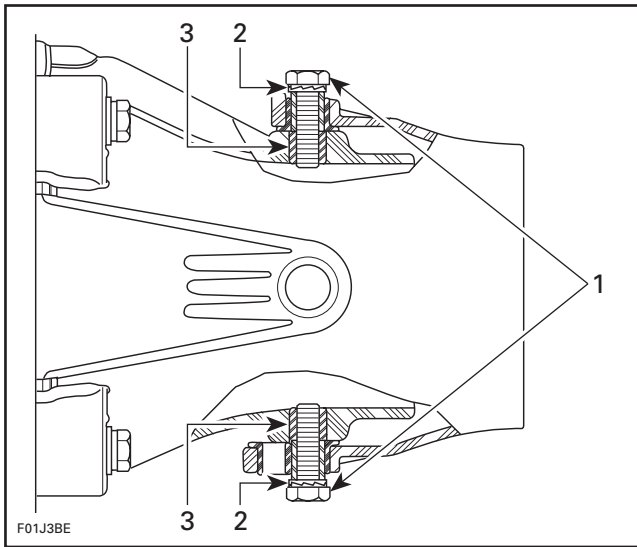

TYPICAL

1. Screw
2. Locking disks
3. Sleeve

Remove nozzle.

SPX, GSI, GSX and XP Models

Disconnect ball joint of VTS link rod.

HX Model

Loosen fasteners retaining trim support to nozzle.

SPX, GSI, GSX, XP and HX Models

Loosen 2 screws each side of trim ring.

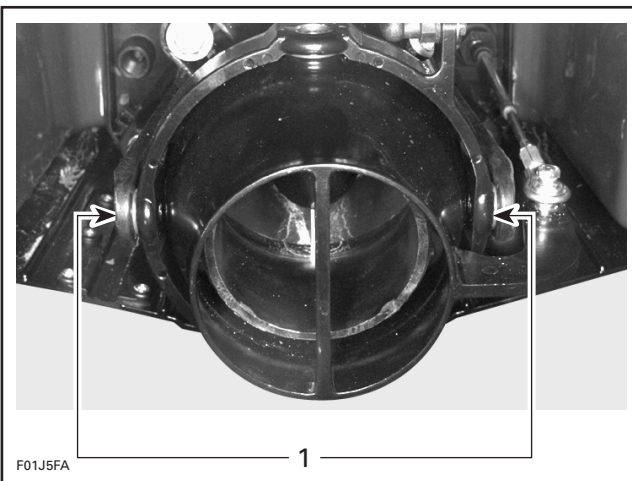

1. Screws

Remove nozzle.

11, Venturi

Remove nozzle **no. 5** prior removing venturi.

Remove 4 retaining screws and withdraw venturi.

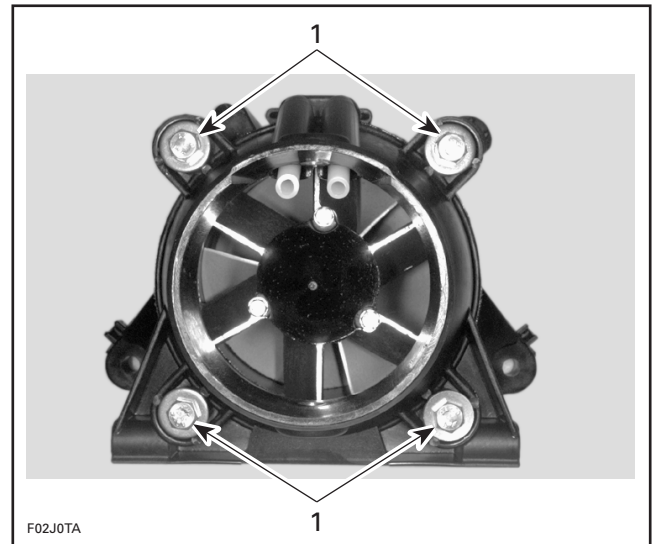

1. Remove screws

9, Jet Pump Housing

NOTE: In the following procedure, jet pump housing is removed with nozzle and reverse gate (if applicable).

SP, SPX and GTS Models

Remove air vent tube support from body opening (SP and SPX models).

Disconnect engine water inlet hose and both bailer pick-up tubes in bilge.

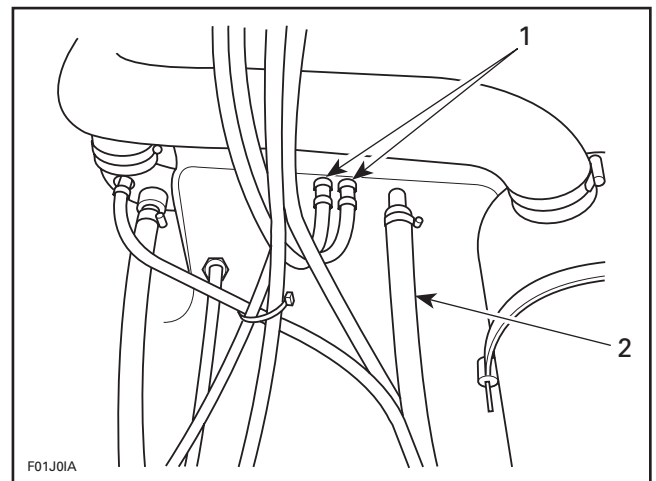

TYPICAL

1. Bailer pick-up tubes
2. Engine water inlet hose

SPX, XP, GSI and GSX Models

Detach ball joint of VTS link rod.

Section 08 PROPULSION SYSTEM

Sub-Section 02 (JET PUMP)

GTS, GTI and GTX Models

Detach ball joint of reverse cable and springs (GTS model) from reverse gate.

All Models

Disconnect steering cable from jet pump nozzle.

Loosen 4 hexagonal nuts **no. 6** and remove flat washers and lock washers from jet pump housing.

Remove jet pump with a wiggle movement.

NOTE: If jet pump can not be removed, the drive shaft may be seized in the impeller splines. Refer to PROPULSION SYSTEM 08-03 to remove drive shaft at the same time.

▼ CAUTION

When removing pump unit, a shim could have been installed between hull and pump housing. Be sure to reinstall it otherwise engine and jet pump alignment will be altered.

DISASSEMBLY

NOTE: Whenever removing a part, visually check for damage such as: corrosion, crack, split, break, porosity, cavitation, deformation, distortion, heating discoloration, wear pattern, missing plating, missing or broken needles in needle bearing, water damage diagnosed by black-colored spots on metal parts, etc. Renew any damaged part. As a quick check, manually feel clearance and end play, where applicable, to detect excessive wear.

SP, SPX and GTS Models

17, Fitting

Fittings can be removed with deep socket or vise grip. Do not contact hose mounting area.

Fittings can be removed from pump housing with the following suggested tool:

- Use a 14 mm (9/16 in) deep socket.
- Drill deep socket with a 14 mm (9/16 in) drill bit, starting at hexagon head end as shown in following illustration.
- Drill a 2.40 mm (3/32 in) hole in center of deep socket as shown in following illustration.
- Install 2.40 mm (3/32 in) roll pin in the center hole.

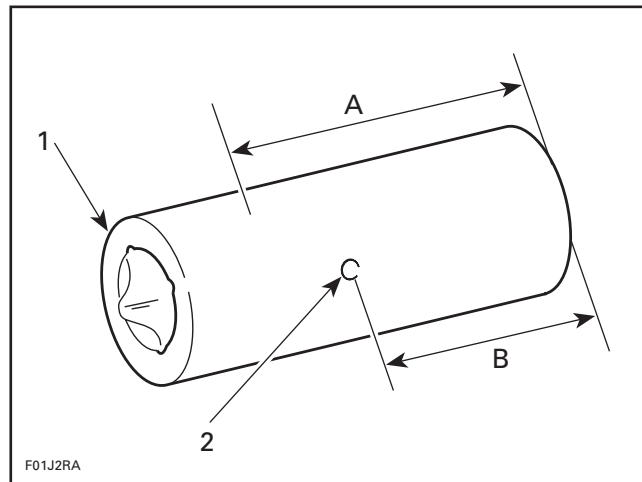

1. Deep socket 14 mm (9/16 in)
2. Roll pin 2.40 mm (3/32 in)
- A. 42.50 mm (1-43/64 in)
- B. 36.80 mm (1-29/64 in)

All Models

18, Cover

With pump assembly in horizontal position, remove 3 retaining screws **no. 19**.

Place container under cover to catch oil.

Using a fiber hammer, gently tap cover to release it from impeller housing.

20, Impeller

Insert impeller shaft holder (P/N 295 000 082) on impeller shaft flat end.

Using 2 screws previously removed from venturi, secure shaft holder to housing.

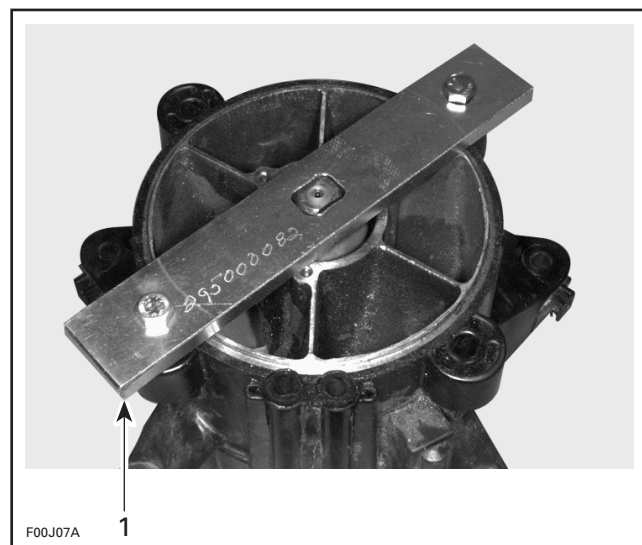

1. Shaft holder

Section 08 PROPULSION SYSTEM
Sub-Section 02 (JET PUMP)

Heat impeller center with a propane torch to approximately 150°C (300°F) to break the Loctite bond.

Install shaft holder in a vice.

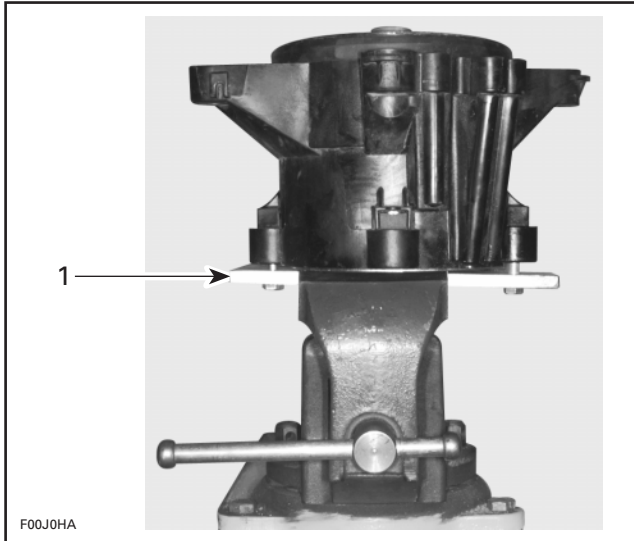

1. Shaft holder

Impeller is loosened using impeller remover tool (P/N 295 000 001).

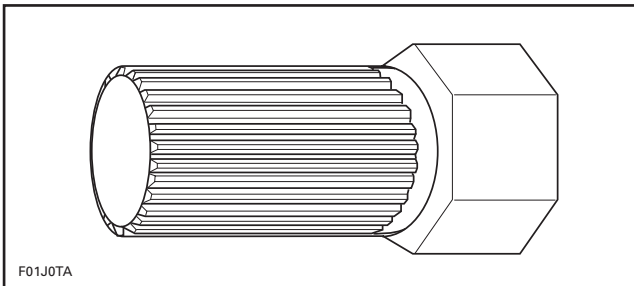

Insert special tool in impeller splines.

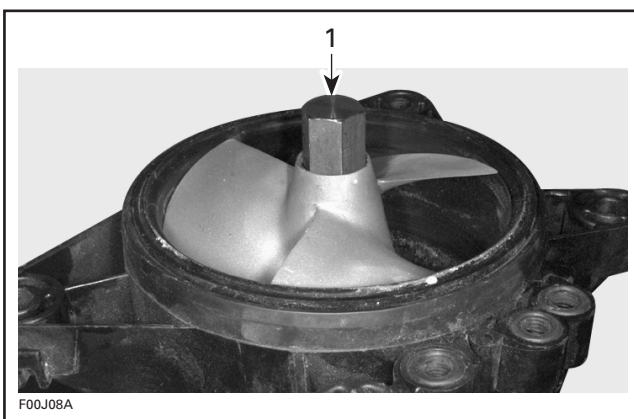

1. Impeller remover tool

Rotate impeller remover tool counterclockwise and unscrew completely impeller.

CAUTION

Never use any impact wrench to loosen impeller.

To remove impeller, apply a rotating movement and pull at same time. Slide impeller out of housing. Remove tool from impeller.

21, Wear Ring

Place impeller housing in a vise with soft jaws. It is best to clamp housing using a lower ear.

Cut wear ring at two places.

NOTE: Wear ring can be cut using a jigsaw, a small grinder or a low clearance hacksaw such as Snap-on HS3 or equivalent.

CAUTION

When cutting ring, be careful not to damage impeller housing.

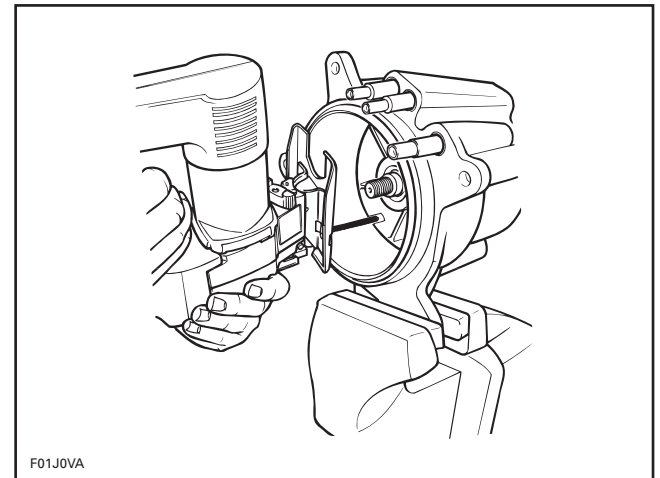

TYPICAL

Section 08 PROPULSION SYSTEM

Sub-Section 02 (JET PUMP)

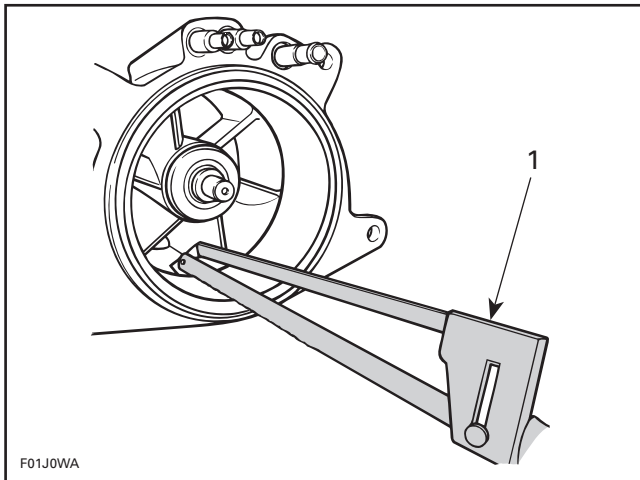

TYPICAL

1. Snap-on HS3

After cutting ring, insert a screwdriver blade between impeller housing and ring outside diameter. Push ring so that it can collapse internally. Pull ring out.

24, Impeller Shaft

Remove shaft holder tool.

Remove impeller shaft with thrust washer and thrust bearing.

22,23, Seal and Needle Bearing

Remove seal and bearings at the same time using bearing/seal remover tool (P/N 295 000 144).

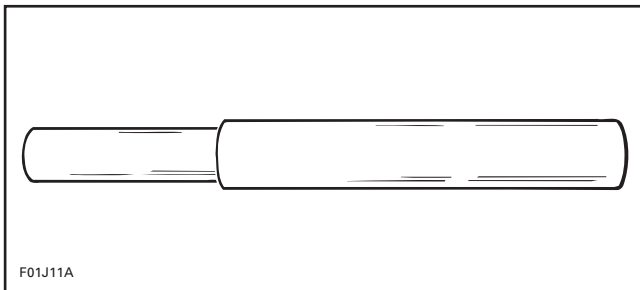

Insert bearing remover then press tool using a arbor press until seal and bearings are out. However, care should be taken not to damage bearing journals.

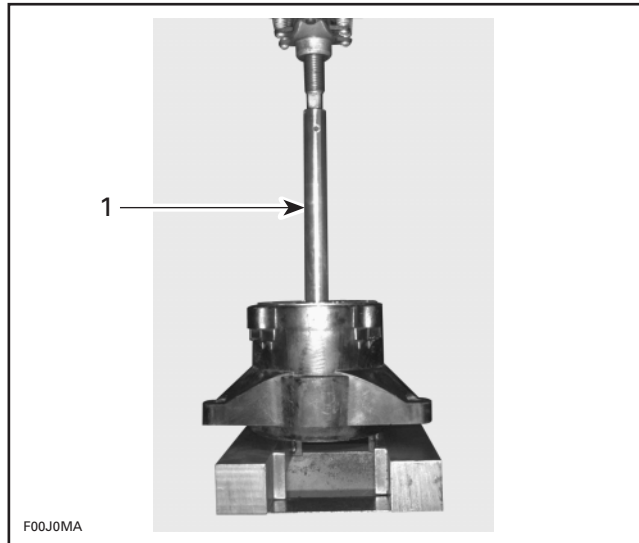

1. Bearing/seal remover tool

NOTE: It is always recommended to renew both bearings, even if only one bearing needs to be replaced.

CLEANING

Sealant can be removed with a wire brush (disc) mounted on a drill or a scraper.

Properly clean all threads.

Remove all O-rings and clean parts in a solvent.

Carefully check water passages and oil passages. Blow low pressure compressed air through them and make sure they are clear.

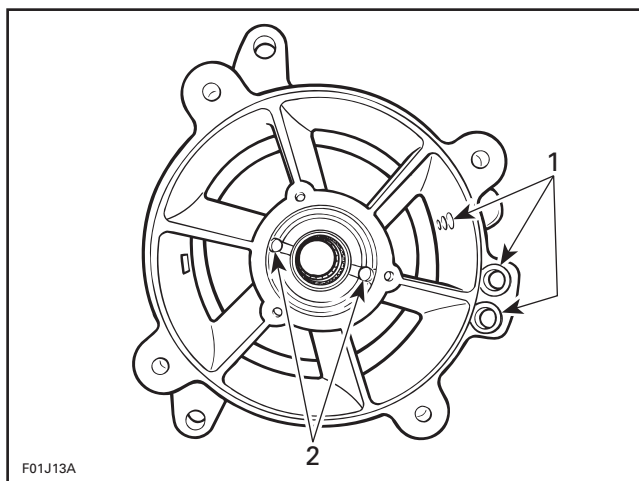

TYPICAL

1. Water passages
2. Oil passages

Brush and clean impeller shaft threads, impeller and drive shaft splines with Loctite Safety solvent 755 (P/N 293 800 019) or equivalent. Free threads and splines from any residue.

▼ CAUTION

Be careful not to damage impeller shaft diameter.

PARTS INSPECTION

20, Impeller

Visually inspect impeller splines. Check for wear or deformation. Renew parts if damaged.

NOTE: Check also PTO flywheel and drive shaft condition. Refer to PROPULSION SYSTEM 08-03.

Examine impeller in wear ring for distortion.

Check if blade tips are blunted round, chipped or broken. Such impeller is unbalanced and will vibrate and damage wear ring, impeller shaft, shaft seal or bearings. Renew if damaged.

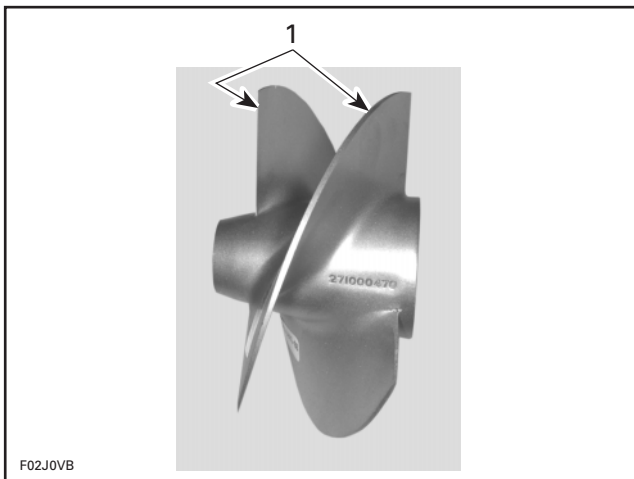

1. Replaced if blunted round or damaged

Check impeller for cavitation damage, deep scratches or any other damage.

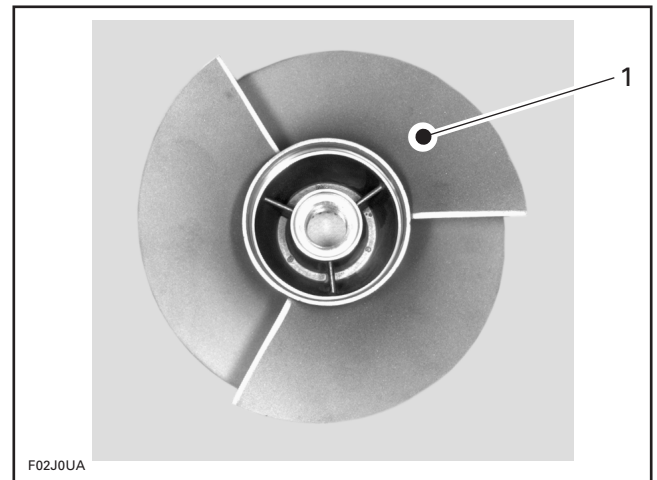

1. Check for cavitation, deep scratches or other damage

21, Wear Ring

Check wear ring for deep scratches, irregular surface or any apparent damage.

If impeller/wear ring clearance is too large and impeller is in good shape, renew wear ring.

22,24, Needle Bearing and Impeller Shaft

WEAR

Inspect needle bearings and their contact surface. Check for scoring, pitting, chipping or other evidence of wear.

With your finger nail, feel contact surface of seal. If any irregular surface is found, renew impeller shaft.

Install bearings, then install impeller shaft and rotate it. Make sure it turns smoothly.

RADIAL PLAY

Radial play is critical for jet pump unit life span.

Radial play of impeller shaft is checked with shaft in housing, without impeller.

Retain housing in a soft jaw vise making sure not to damage housing lug.

Set a dial gauge and position its tip onto shaft end, close to end of threads.

Move shaft end up and down. Difference between highest and lowest dial gauge reading is radial play.

Maximum permissible radial play is 0.05 mm (.002 in).

Section 08 PROPULSION SYSTEM

Sub-Section 02 (JET PUMP)

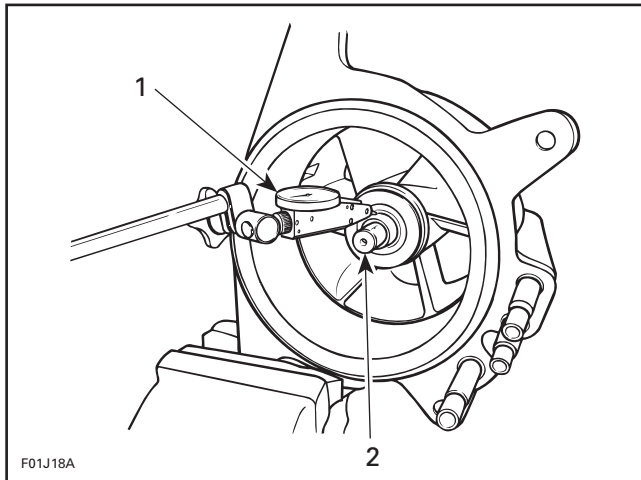

TYPICAL — MEASURING IMPELLER SHAFT RADIAL PLAY

1. Dial gauge
2. Measure close to threads at shaft end

To check both bearings, proceed the same way with other shaft end. Position gauge tip on diameter, close to flats on shaft.

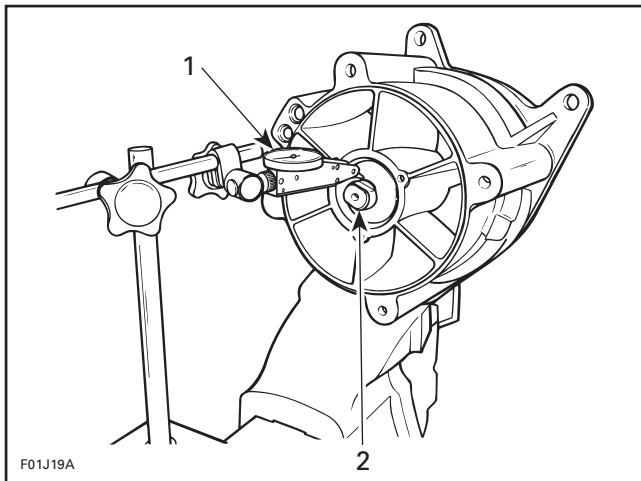

TYPICAL — MEASURING IMPELLER SHAFT RADIAL PLAY

1. Dial gauge
2. Measure close to flats at shaft end

Excessive play can come either from worn bearings or impeller shaft or damaged impeller housing bearing surfaces.

Measuring shaft diameter will determine the defective parts.

Using a micrometer, measure diameter on bearing contact surfaces. **Minimum** shaft diameter should be 22.24 mm (.876 in).

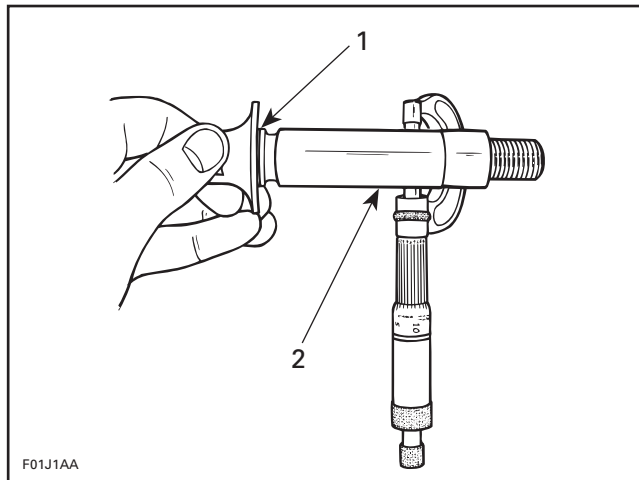

1. Inspect for wear at the bearing pilot
2. Radial bearing raceway

NOTE: If shaft is to be replaced, it is recommended to replace both bearings at the same time. In addition, it is suggested to replace thrust bearing and thrust washer.

25,26, Thrust Washer and Thrust Bearing

Visually inspect thrust washer, thrust bearing and their contact surface. Check for scoring, pitting, flaking, discoloration or other evidence of wear. For best inspection, use a 7X magnifying glass to check wear pattern.

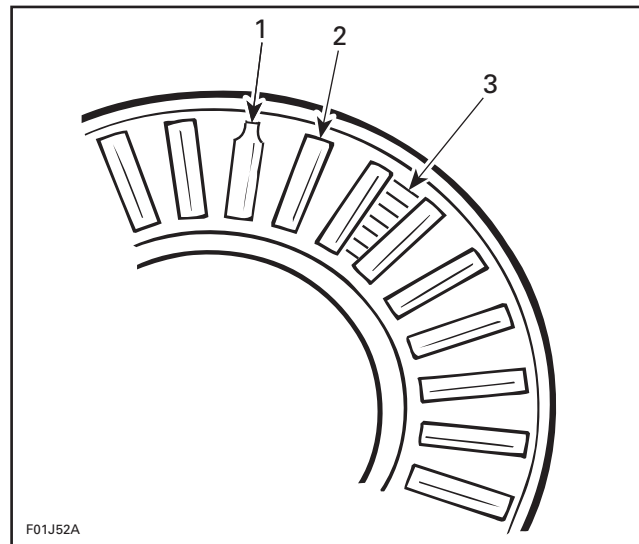

TYPICAL

1. Worn roller (trunnion worn on end roller)
2. Good roller (cylindrical shape)
3. Look for scoring on retainer

NOTE: When replacing either washer or bearing, it is recommended to renew both.

18,24, Cover and Impeller Shaft

END PLAY

End play of impeller shaft is checked with shaft in housing, without impeller and with cover installed.

Retain housing in a soft jaw vise making sure not to damage housing lug. Set a dial gauge and position its tip on the end of shaft. Move shaft end by pulling and pushing. Difference between highest and lowest dial gauge reading is end play. Maximum permissible end play (new) is 0.12 – 0.54 mm (.005 – .021 in). Make sure vise is secured and not adding to your measurement as you move impeller shaft.

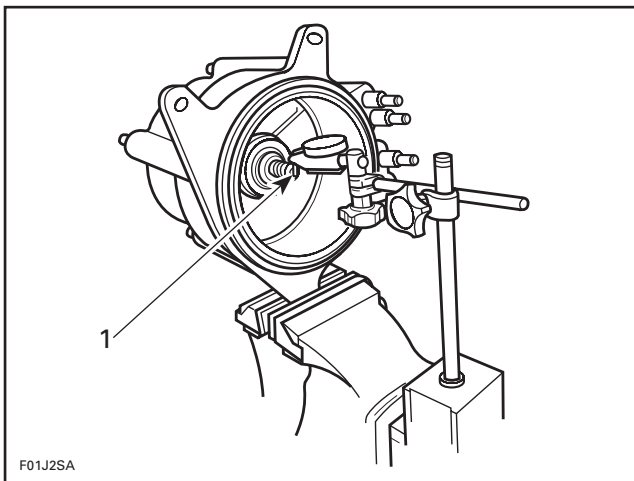

1. Tip on shaft end

Excessive play comes from a worn anti-knock pusher inside cover and wear of impeller shaft nose.

Visually inspect pusher inside cover.

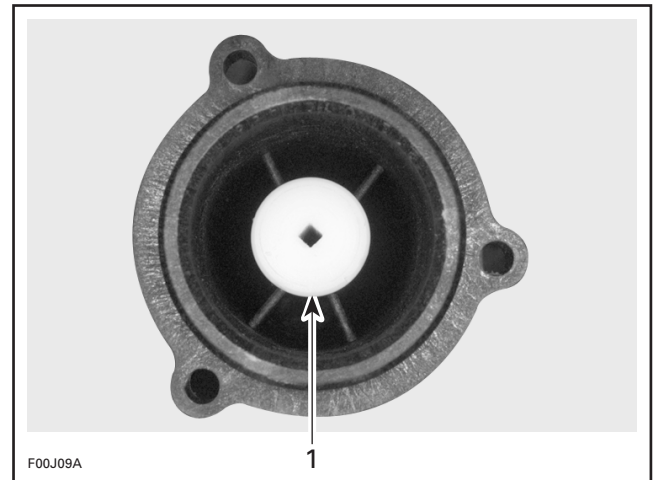

TYPICAL

1. Pusher

If impeller shaft end play is excessive, pusher should be replaced.

Use pliers to pull pusher and spring from cover.

Be sure to check end play after installing a new pusher.

Inspect impeller shaft nose for wear.

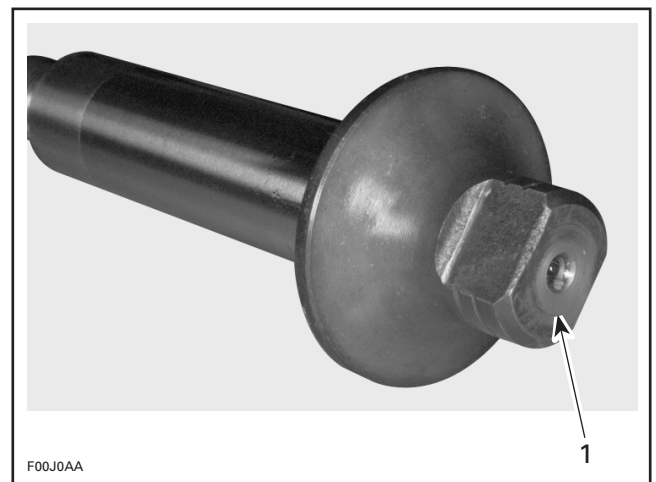

1. Impeller shaft nose

22, Seal

Carefully inspect seal lips. Make sure that lips are not worn, distorted, cracked or show signs of any other damage. Renew as necessary.

ASSEMBLY

21, Wear Ring

The wear ring features a lip on one edge; position lip outwards of housing.

Section 08 PROPULSION SYSTEM

Sub-Section 02 (JET PUMP)

NOTE: To ease insertion into housing, apply BOMBARDIER LUBE lubricant (P/N 293 600 016) onto outside circumference of wear ring.

To install ring in housing, use a square steel plate of approximately 180 × 180 mm × 6 mm thick (7 × 7 in × 1/4 in) and a press.

Manually engage ring in housing making sure it is equally inserted all around. Press ring until it seats into bottom of housing.

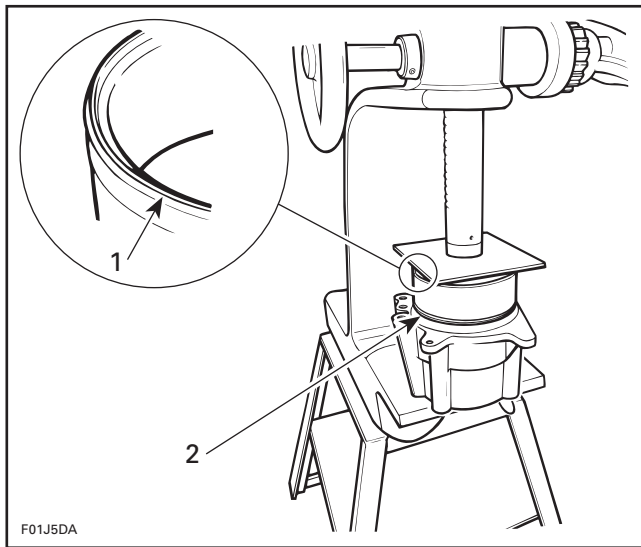

1. Seal lip
2. Press wear ring

If a press is not readily available, a piece of wood such as a 2 × 4 × 12 in long, can be used.

Manually engage ring in housing making sure it is equally inserted all around. Place wood piece over ring. Using a hammer, strike on wood to push ring. Strike one side then rotate wood piece about 90° and strike again. Frequently rotate wood piece so that ring slides in evenly until it seats into bottom of housing.

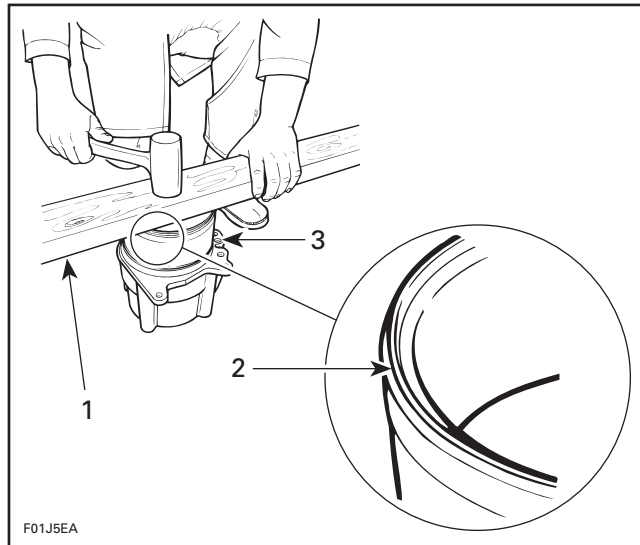

1. Piece of wood
2. Seal lip facing upward
3. Wear ring

22,23, Seal and Needle Bearing

Bearings and seal will be properly installed in housing using bearing/seal installer tool (P/N 295 000 107).

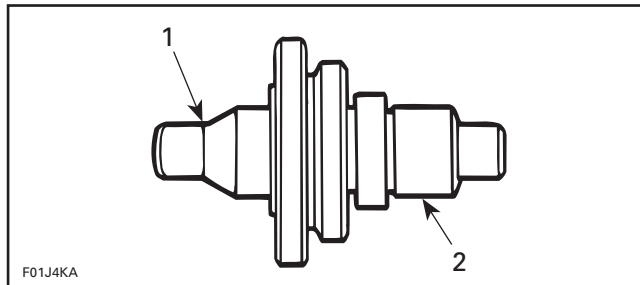

BEARING/SEAL INSTALLER TOOL

1. Seal side
2. Bearing side

Stamped end of bearings (showing identification markings) must be located toward outside of housing.

Properly insert bearing on tool. Using an arbor press only, push tool until tool flange contacts housing. Proceed the same way for both bearings.

Section 08 PROPULSION SYSTEM
Sub-Section 02 (JET PUMP)

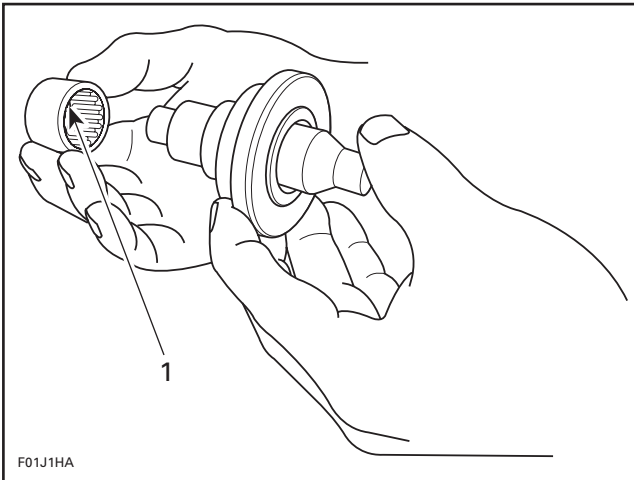

1. Stamped end this side

▼ CAUTION

Never hammer the bearing into its housing.

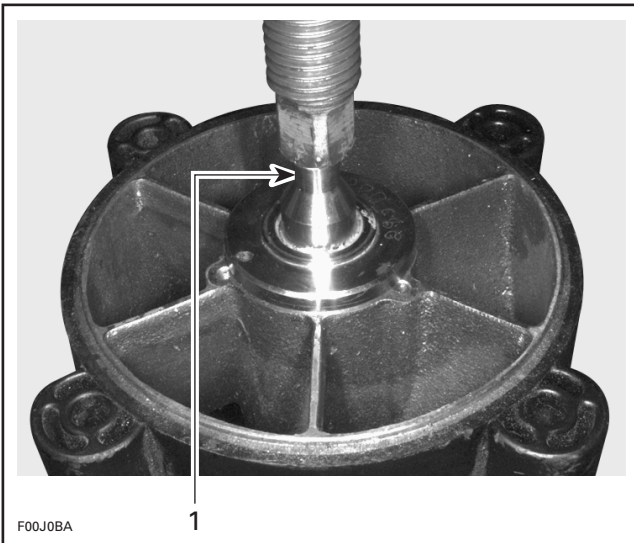

1. Press on tool until it stops

▼ CAUTION

This tool have been designed to properly position bearings and seal, thus providing space for lubrication purposes. The tool flanges allow this. If a different pusher type is being used, components must be properly positioned as follows.

Bearing on impeller side must be 1.5 to 2.5 mm (.060 – .100 in) inside reservoir measured from seal seat. Bearing on venturi side must be 2 to 3 mm (.080 – .120 in) inside reservoir measured from thrust washer seat. Refer to following illustration.

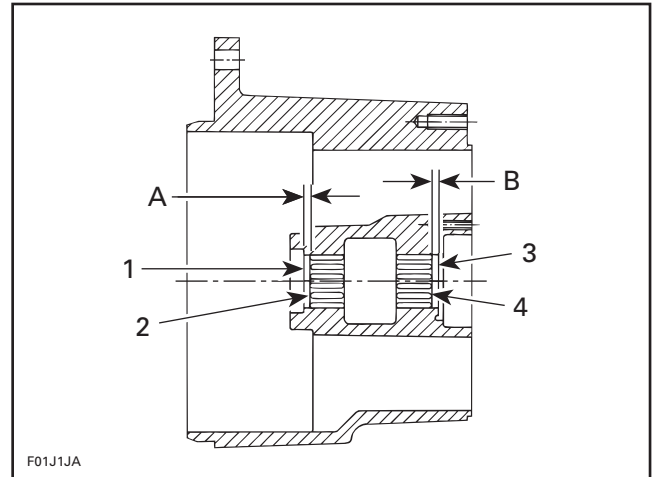

- 1. Seal seat
- 2. Stamped end of bearing
- 3. Thrust washer seat
- 4. Stamped end of bearing
- A. 1.5 – 2.5 mm (.060 – .100 in)
- B. 2 – 3 mm (.080 – .120 in)

Seal must be installed so that lips raised edges are toward outside of housing (toward impeller).

Apply Loctite 518 (P/N 293 800 038) to seal housing, all around outer diameter and on seal seat.

Properly insert seal on tool.

NOTE: It is important when installing seals to pack seal lip with grease before inserting bearing/seal installer tool. Properly insert tool in seal with a rotating movement.

Section 08 PROPULSION SYSTEM

Sub-Section 02 (JET PUMP)

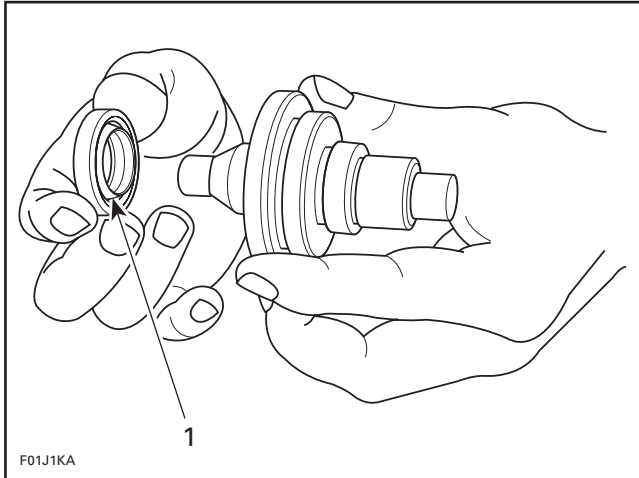

1. Raised edge of seal this side



CAUTION

Prevent sealant from contacting any needles of bearing.

Push on tool end with a press until tool flange contacts housing.

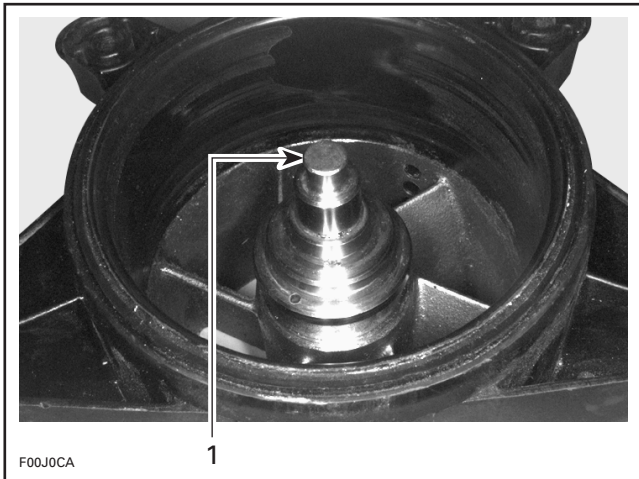

1. Press on tool until it stops

Apply synthetic grease (P/N 293 550 010) between seal lips.

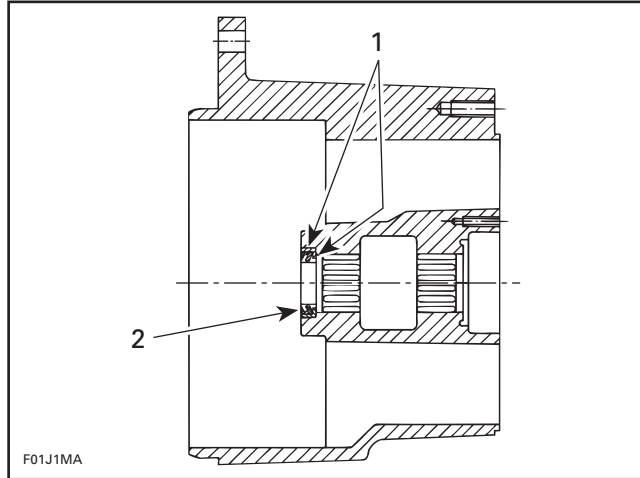

1. Loctite 518 all around and behind
2. Raised edge of seal lip this side

25, Thrust Washer

Position jet pump housing no. 9 with the stator vanes on top.

Insert thrust washer no. 25 in the stator seat.

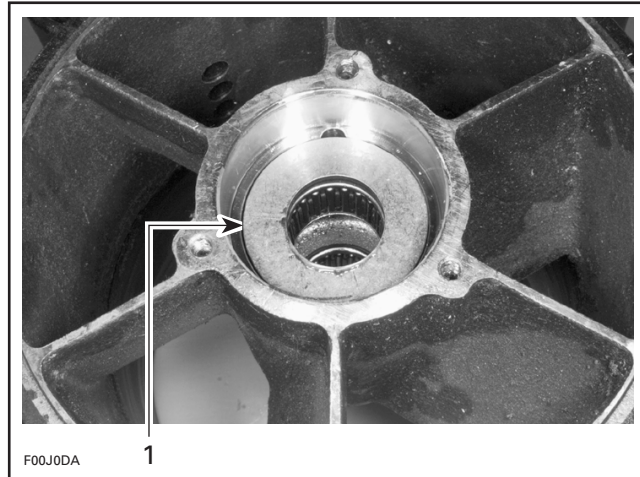

1. Thrust washer properly installed in stator seat

26, Thrust Bearing

Apply Sea-Doo jet pump synthetic oil (P/N 293 600 011) on both sides of thrust bearing.

Position thrust bearing no. 26 on thrust washer no. 25.

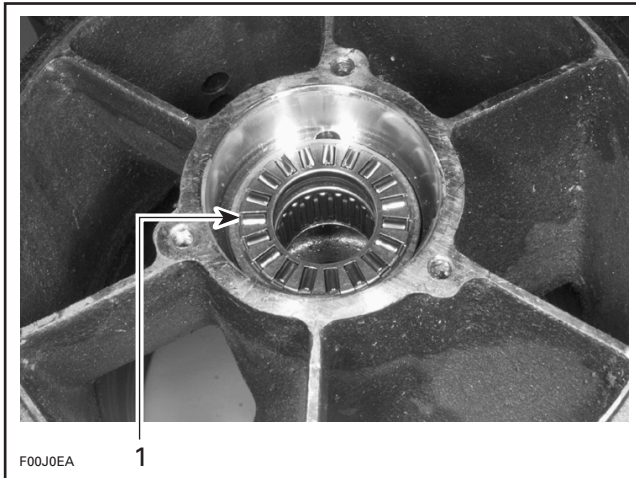

1. Thrust bearing on top of thrust washer

24, Impeller Shaft

To prevent seal lip damage when inserting impeller shaft, use impeller shaft guide (P/N 295 000 002).

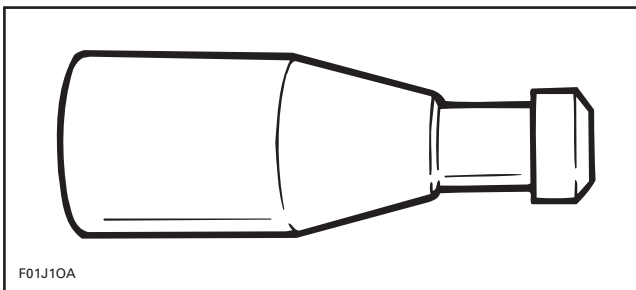

Insert tool onto shaft end then carefully install shaft in impeller housing.

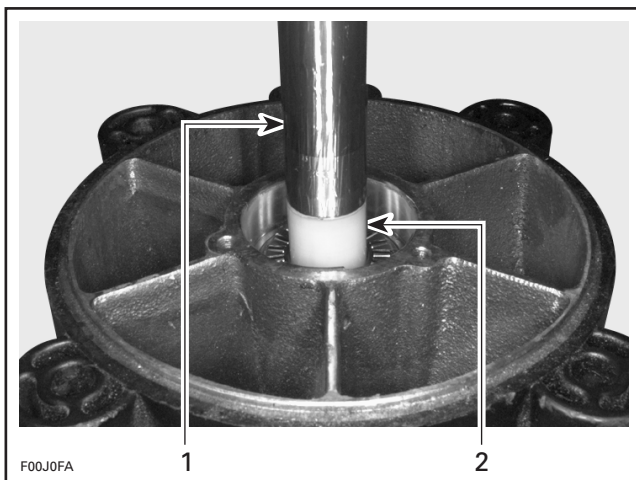

1. Impeller shaft
2. Impeller shaft guide

NOTE: If jet pump housing rest against a table, raise it slightly to allow complete shaft insertion with the shaft guide.

Remove shaft guide.

20, Impeller

Apply Loctite primer N (P/N 293 600 012) on threads of impeller shaft no. 24. Allow to dry for 2 minutes.

NOTE: Loctite primer is used to reduce Loctite 271 curing time and to activate stainless steel and aluminum surfaces for better bonding action. If applied, complete curing time is 6 hours, if primer is not used, allow 24 hours for curing time.

Apply Loctite 271 (red) to shaft threads.

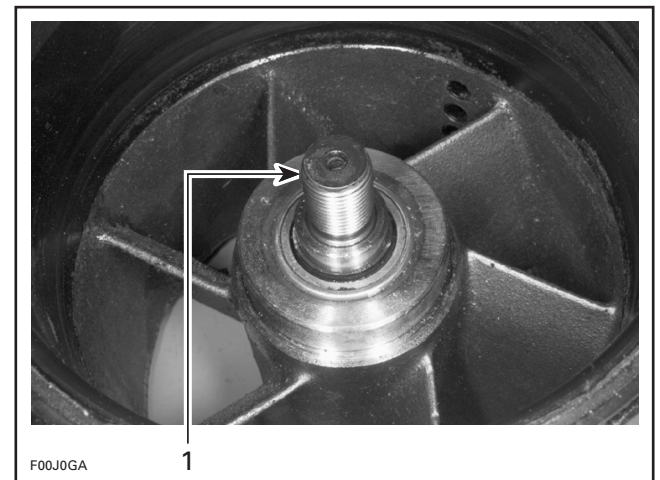

1. Apply Loctite 271 (red) on threads

Using 2 screws previously removed from venturi, secure impeller shaft holder tool to housing.

Install shaft holder tool in a vice.

Section 08 PROPULSION SYSTEM

Sub-Section 02 (JET PUMP)

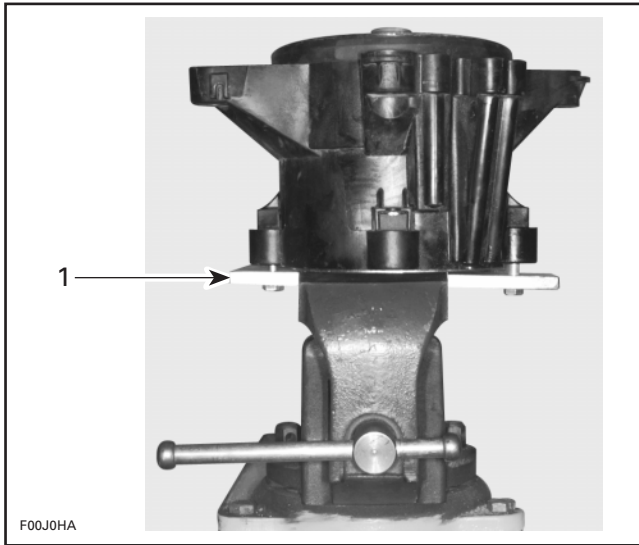

1. Impeller shaft holder secured in a vice

To ease impeller installation, apply BOMBARDIER LUBE lubricant on wear ring.

Insert impeller into wear ring. Manually rotate impeller and push so that it slides on impeller shaft threads. Carefully engage threads making sure they are well aligned.

Install impeller remover/installer tool into impeller splines and tighten.

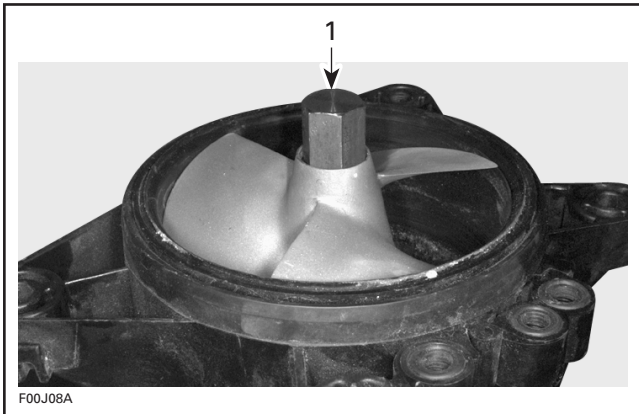

1. Impeller remover/installer tool

▼ CAUTION

Make sure thrust washer and bearing are not wedged in shaft groove. To check, manually pull and push impeller housing, some axial play must be felt (maximum 0.54 mm (.021 in)).

Torque impeller to 70 N•m (52 lbf•ft) then remove tools.

▼ CAUTION

Never use any impact wrench to tighten impeller.

Apply synthetic grease (P/N 293 550 010) on impeller splines.

Insert a new boot no. 15 and ring no. 16 to impeller.

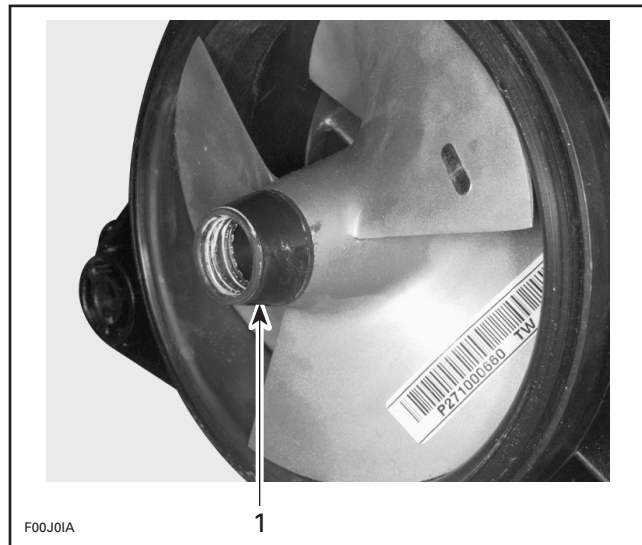

1. Boot and ring

18, Cover

Install O-ring no. 27 to cover. Apply Loctite 518 on O-ring. Install cover to impeller housing making sure to properly position filler plug on top side.

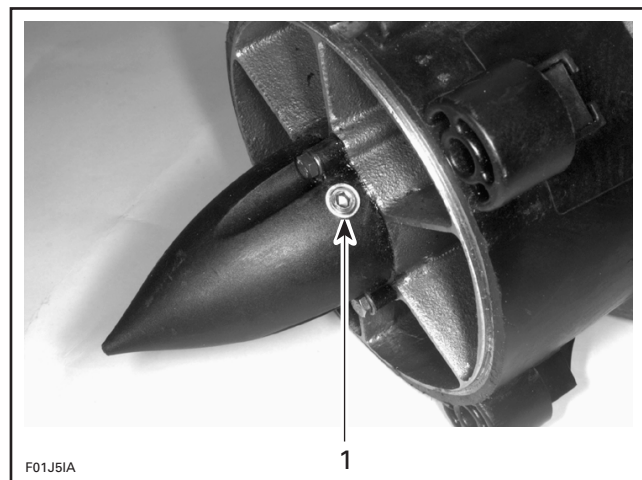

1. Filler plug toward top side of pump housing

Apply Loctite 242 (blue) on screw threads and evenly tighten cover screws. Torque to 4 N•m (35 lbf•in).

Oil Fill

NOTE: It is highly recommended to perform a leakage test prior adding the oil. Refer to PUMP PRESSURIZATION in this sub-section.

Place housing horizontally as in its operating position so that filler plug is located on top. Remove filler plug from cover. Pour SEA-DOO JET PUMP SYNTHETIC OIL (P/N 293 600 011) in reservoir until oil comes level with bottom of hole. Let oil drain into housing and after a few minutes add more oil until it is level with bottom of filler hole. Oil capacity is 70 mL (2.4 oz).

 CAUTION
<p>This is a synthetic oil. Do not mix with mineral based oil. Do not mix oil brands.</p>

NOTE: When filling reservoir, oil must be poured into cover quite slowly to allow complete housing fill.

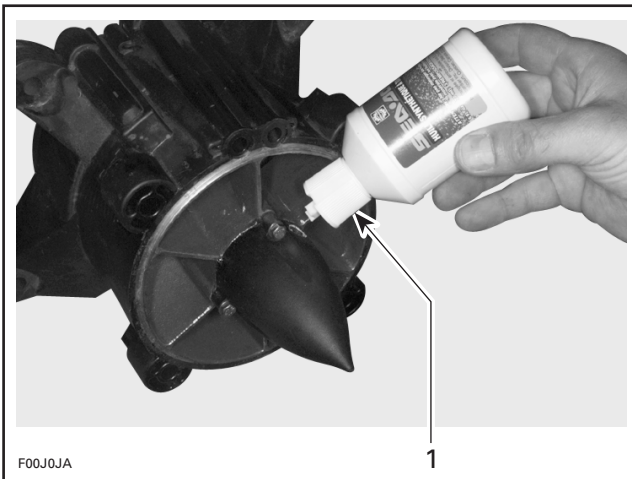

TYPICAL

1. Pour oil slowly until it is level with bottom of filler hole

11, Venturi

If needed, install new O-rings **no. 10** around bailer passages.

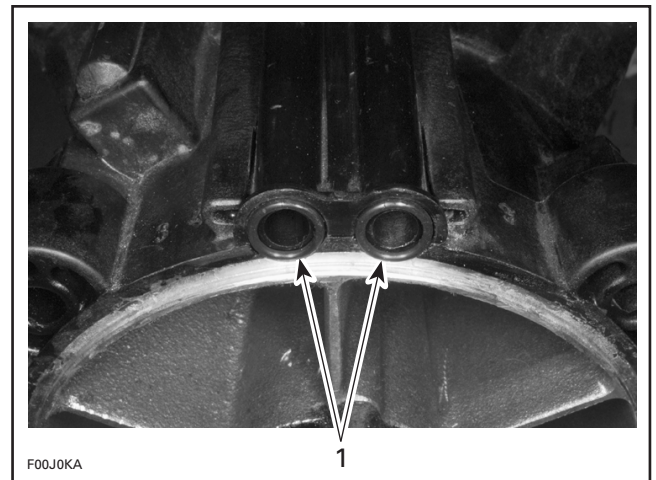

1. O-rings

Apply Loctite 518 (Gasket Eliminator) on mating surface.

Position venturi with bailer passages on top.

Apply Loctite 242 (blue) on threads of screws **no. 12**.

NOTE: On the GTI and GTX models, install the reverse support with the venturi.

Install screws **no. 12**, lock washers **no. 13** and flat washers **no. 14** then torque to 21 N•m (16 lbf•ft).

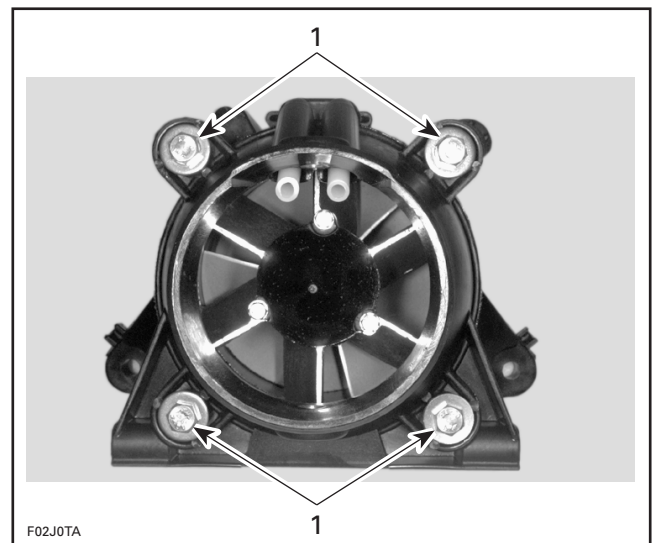

1. Torque screws to 21 N•m (16 lbf•ft)

17, Fitting

SP, SPX and GTS Models

Apply Loctite PST 592 on plastic fitting threads. Then thread fitting into pump housing until threads are bottomed.

Section 08 PROPULSION SYSTEM

Sub-Section 02 (JET PUMP)

29, O-Rings

GS, GSI, GSX, GTI, GTX, HX and XP Models

Install O-rings no. 29 around bailer passages or make sure they are in place if they were not removed.

PUMP PRESSURIZATION

Whenever doing any type of repair on jet pump, a pressure test should be done to check for leakage.

Proceed as follows:

- Remove drain plug from cover.
- Apply Loctite PST 592 on threads of fitting tool (P/N 295 000 086) then secure on cover.
- Connect pump gauge tester (P/N 295 000 085) to fitting.
- Pressurize pump to a maximum of 70 kPa (10 PSI).

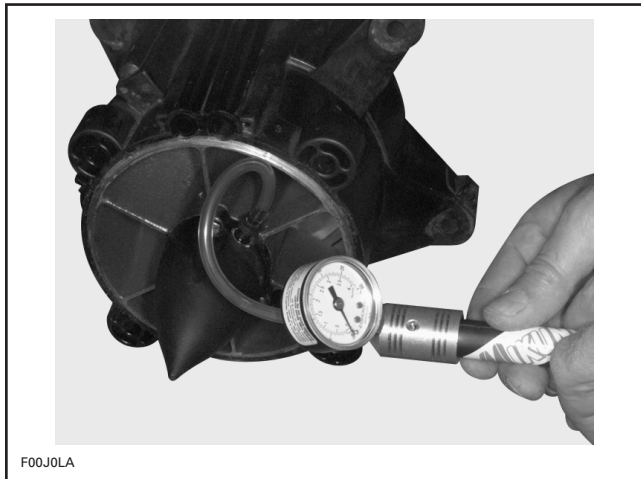

- Pump must maintain this pressure for at least 10 minutes.

▼ CAUTION

Repair any leak, failure to correct a leak will lead to premature wear of pump components.

NOTE: If there is a pressure drop spray soapy water around cover. If there are no bubbles, impeller shaft, impeller shaft seal, or impeller housing is leaking through porosity and has to be replaced. Jet pump unit has to be disassembled. If jet pump has been overhauled, the impeller shaft seal no. 22 may be leaking; Add a small quantity of Sea-Doo jet pump synthetic oil to wet the oil seal. Let soak and recheck.

- Disconnect pump gauge tester and remove fitting.
- Check oil level. Refill as necessary.
- Apply Loctite PST 592 to threads of filler plug then secure it in cover.

INSTALLATION

28, Neoprene Seal

SP, SPX and GTS Models

If neoprene seal is damaged, replace it with a new one.

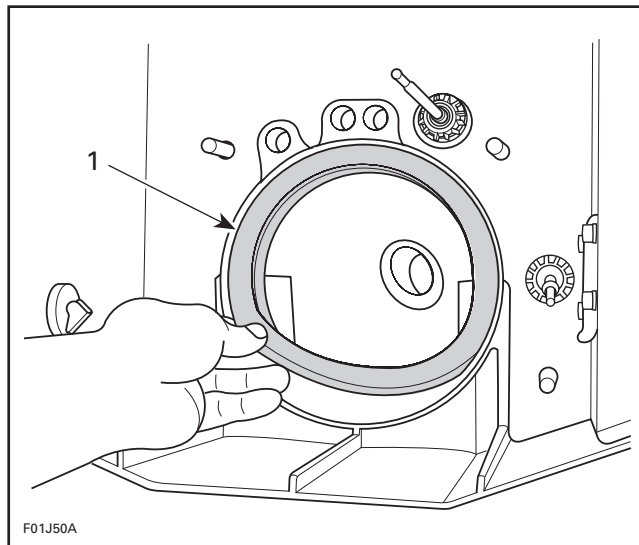

TYPICAL

1. Neoprene seal

9, Jet Pump Housing

SP, SPX and GTS Models

Apply Loctite 598 Ultra Black around bailer and water supply fittings.

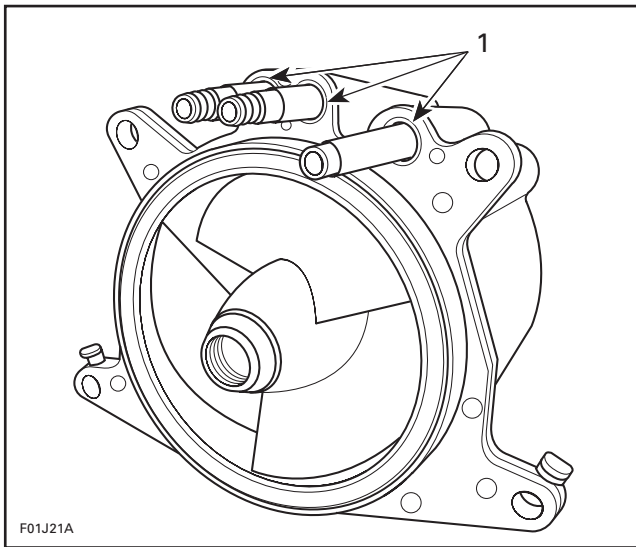

1. Apply Loctite 598 Ultra Black where indicated

All Models

Generously apply synthetic grease on drive shaft splines.

Make sure rubber damper is on drive shaft end.

Install jet pump. If necessary, wiggle jet pump to engage drive shaft splines in impeller.

▼ CAUTION

Some watercraft require a shim between hull and pump; if shim has been removed at pump removal, be sure to reinstall it, otherwise engine alignment will be altered.

Apply Loctite 242 (blue) on stud threads of jet pump housing.

Install flat washers **no. 8**, lock washers **no. 7** and nuts **no. 6**. Tighten nuts of impeller housing in a criss-cross sequence and torque to 33 N•m (24 lbf•ft).

NOTE: Slightly lubricate wear ring with BOMBARDIER LUBE lubricant to minimize friction during initial start.

SP, SPX and GTS Models

Secure water supply hose and both bailer tubes to impeller housing using tie raps.

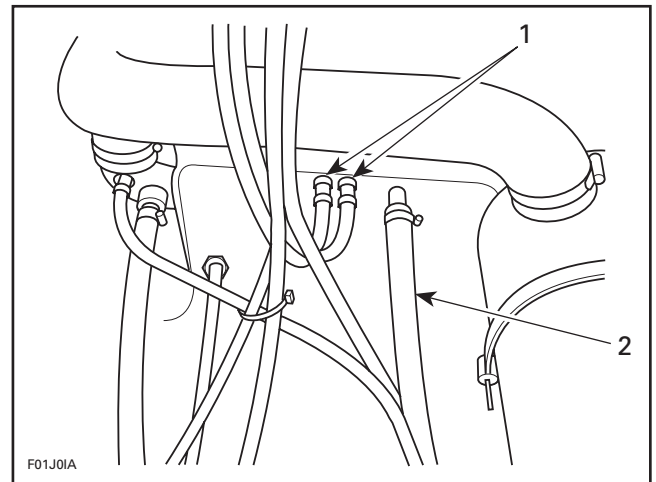

1. Bailer tubes
2. Water inlet hose

Reinstall air vent tube support onto body (SP/SPX models).

5, Nozzle

SP, GS, GTS, GTI and GTX Models

Insert bushings **no. 3** in nozzle **no. 5**, positioning their flanges from inside of nozzle.

Insert sleeves **no. 2** in bushings **no. 3**.

Install nozzle **no. 5** on venturi **no. 11**; position its steering arm on RH side. Apply Loctite 242 (blue) on screw threads (or use new screws with pre-applied threadlocker). Install screws **no. 1** and locking disks **no. 4** then torque to 20 N•m (15 lbf•ft).

Section 08 PROPULSION SYSTEM

Sub-Section 02 (JET PUMP)

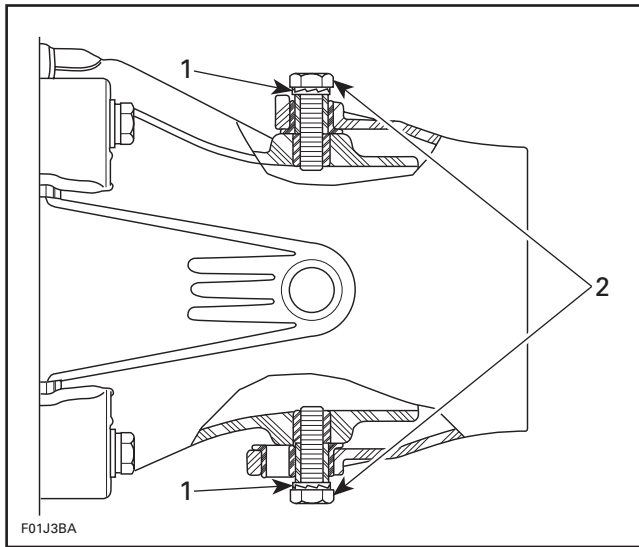

TYPICAL

1. Locking disks
2. Torque screws to 20 N•m (15 lbf•ft)



WARNING

Whenever removing screw always renew locking disks. Screw must be torqued as specified.

SPX, GSI, GSX, HX and XP

Install nozzle/trim ring assembly.

Torque screws to 14 N•m (10 lbf•ft).

NOTE: Trim ring has a tight fit; to install, insert both sides at the same time, taking care not to break plastic bushings. Carefully use a plastic tip hammer if necessary. Make sure steering arm of jet pump is on right side and trim arm is above venturi.

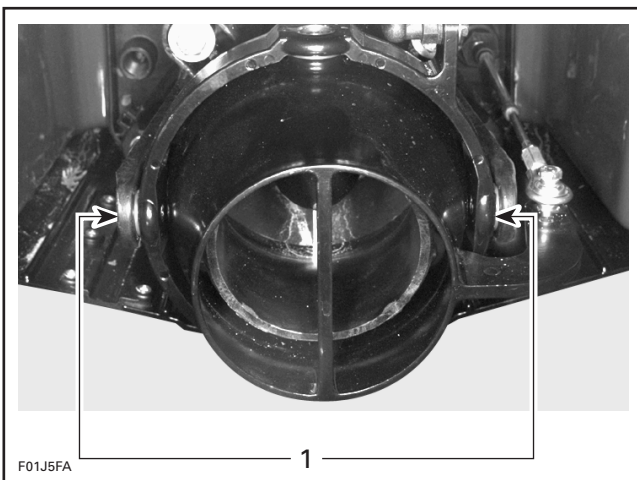

1. Torque screws to 14 N•m (10 lbf•ft)

Steering Cable

Refer to STEERING SYSTEM 09.

Trim System

Refer to PROPULSION SYSTEM 08-05.

Reverse Cable

Refer to PROPULSION SYSTEM 08-04.

DRIVE SYSTEM

SP, SPX, GS, GSI, GTS and GTI Models

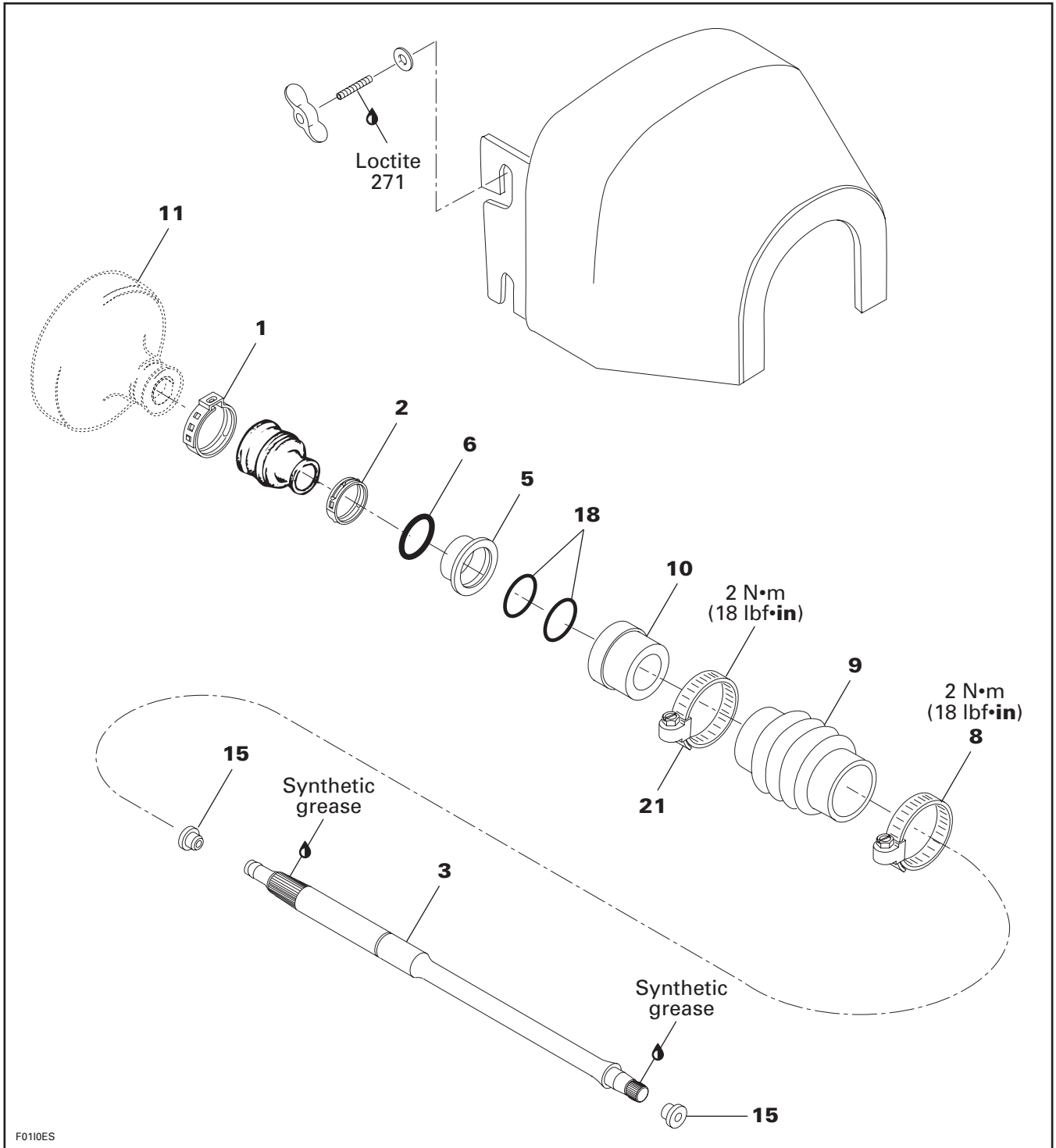

Section 08 PROPULSION SYSTEM

Sub-Section 03 (DRIVE SYSTEM)

GSX and GTX Models

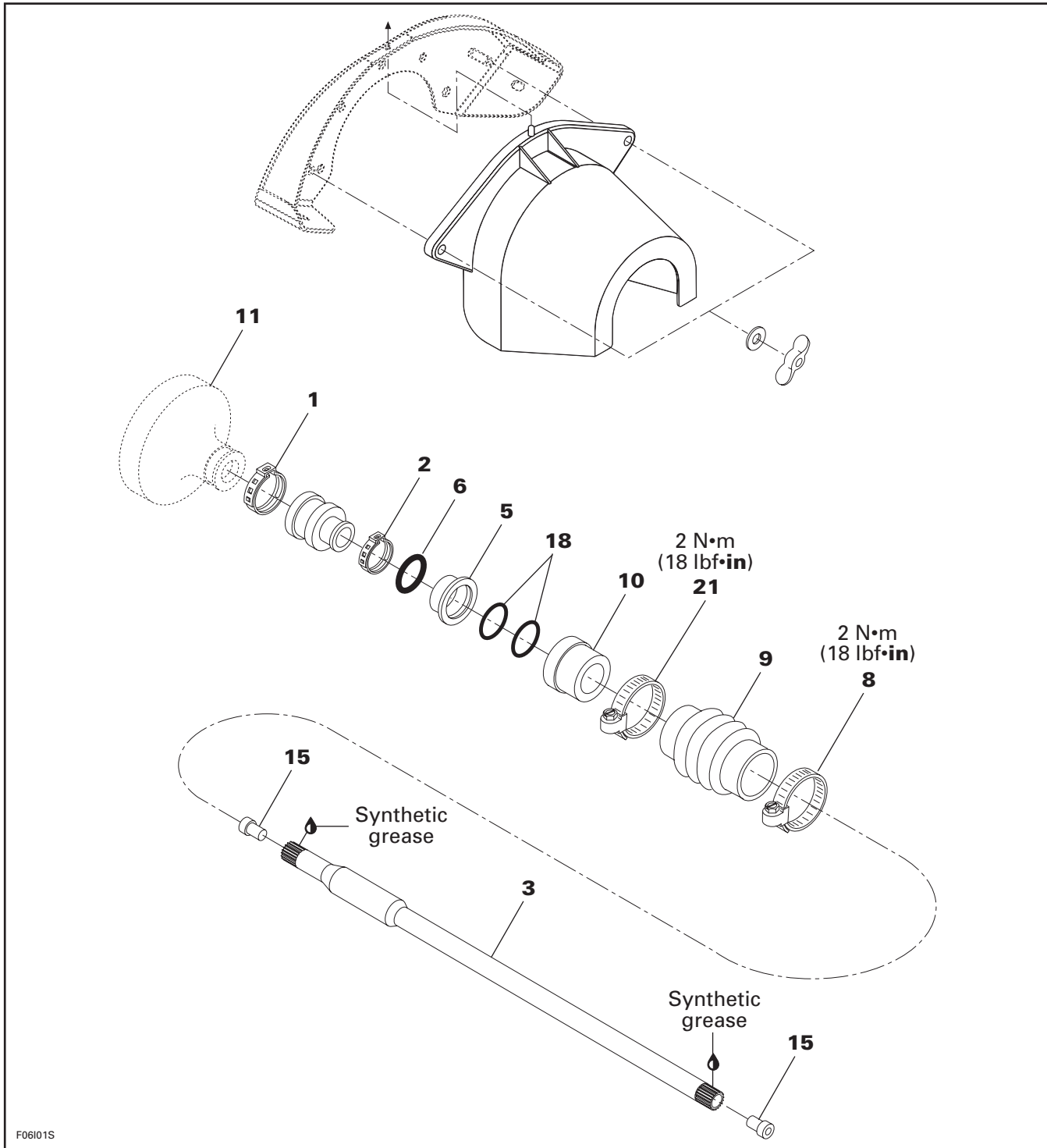

Section 08 PROPULSION SYSTEM

Sub-Section 03 (DRIVE SYSTEM)

XP and HX Models

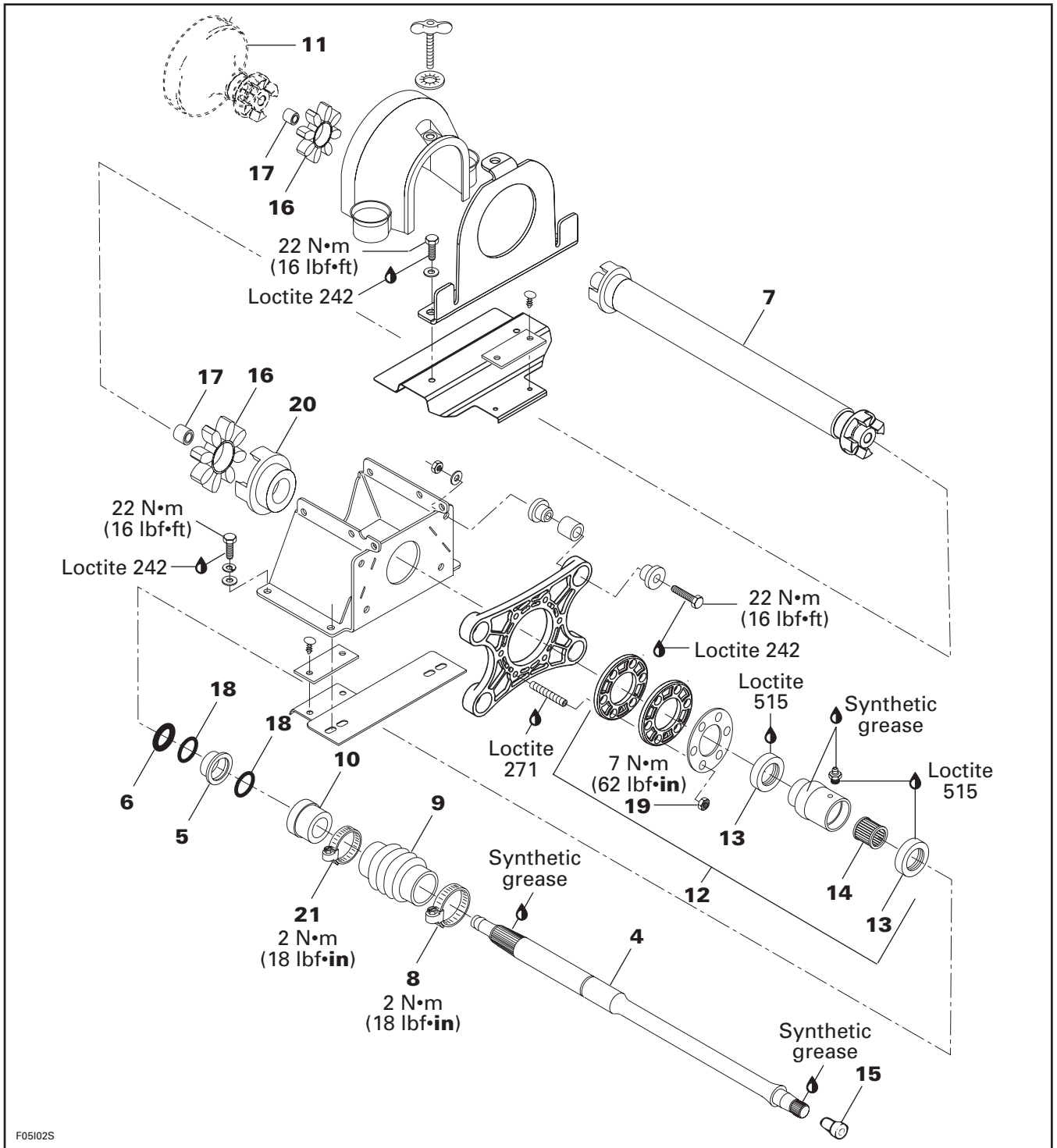

F05102S

Section 08 PROPULSION SYSTEM

Sub-Section 03 (DRIVE SYSTEM)

GENERAL

Jet pump must be removed to replace any components of the drive system. Refer to PROPULSION SYSTEM 08-02 for jet pump removal procedure.

REMOVAL

All Models Except the XP and HX

Remove seat.

Remove PTO flywheel guard.

1, Large Clamp

Unfasten large clamp of PTO flywheel boot as follows:

- Use pliers (P/N 295 000 069).

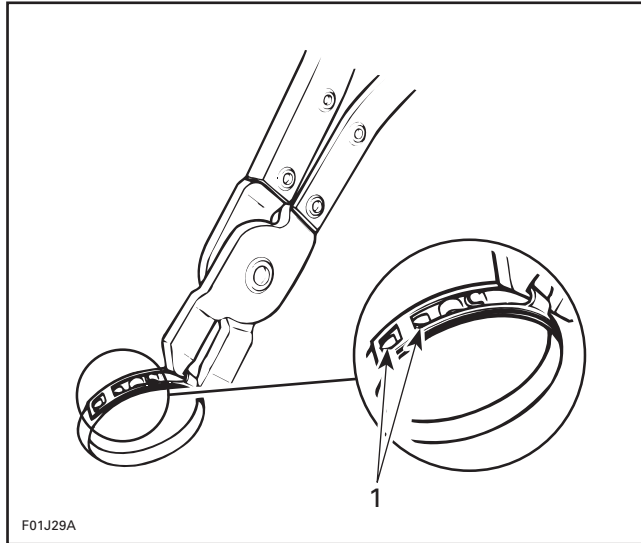

F01J29A

TYPICAL

1. Locking hooks

2, Small Clamp

Unfasten small clamp of PTO flywheel boot as follows:

- Use pliers (P/N 295 000 054).

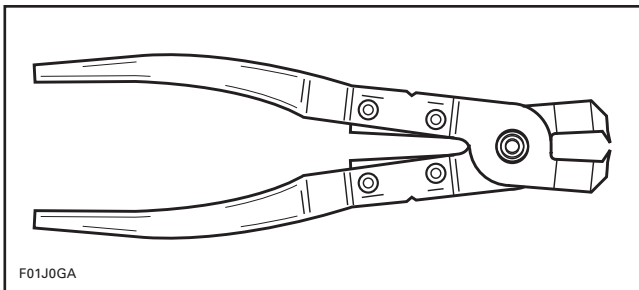

F01J06A

- Insert pointed tips of pliers in closing hooks.

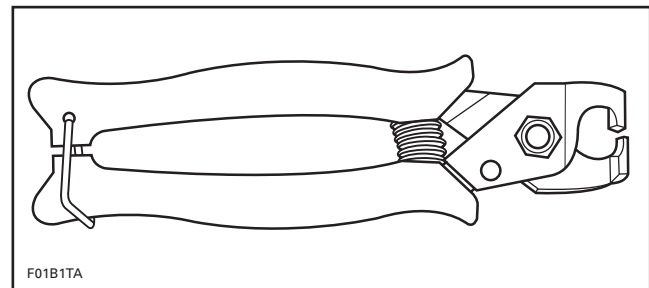

F01B17A

- To open clamp, place flat side of plier on clamp embossment, squeeze and twist plier.

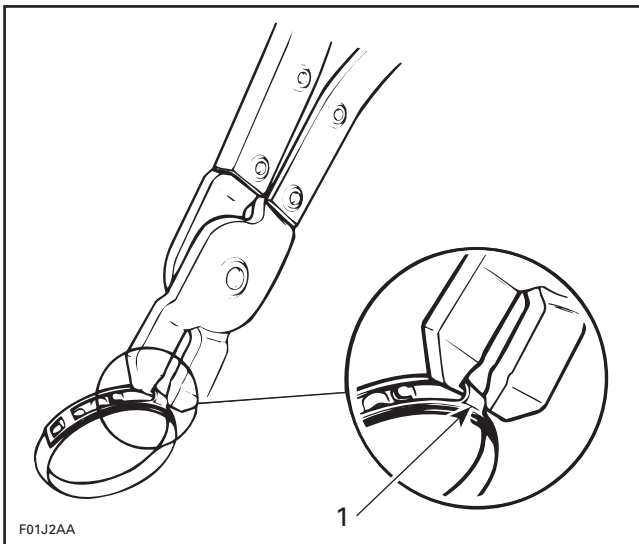

F01J2AA

TYPICAL

1. Closing hooks

- Squeeze pliers to draw hooks together and disengage windows from locking hooks.

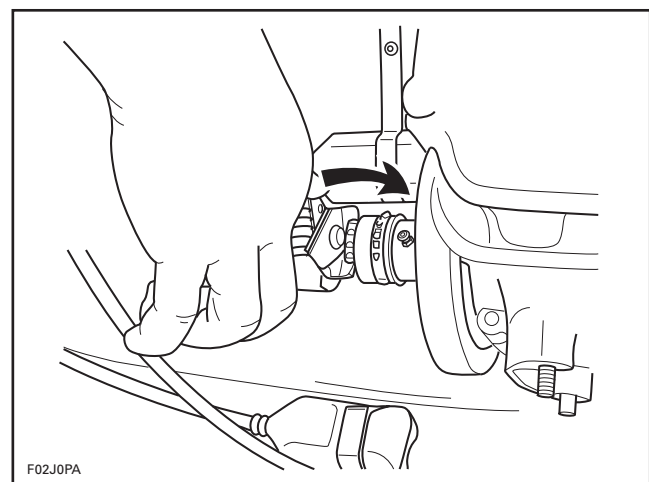

F02J0PA

XP and HX Models

Remove rear access panel.

All Models

5,6, Floating Ring and O-ring

Hold floating ring no. 5 and compress boot no. 9; then, pull out O-ring no. 6 from drive shaft groove.

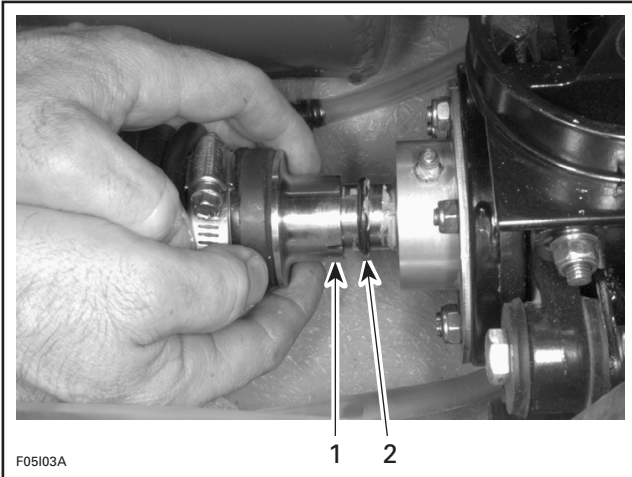

1. Floating ring
 2. O-ring

All Models Except the XP and HX

3, Drive Shaft

Simply pull out drive shaft.

NOTE: If the drive shaft is jammed into PTO flywheel, make the following tool and use it in conjunction with the impeller housing remover (P/N 295 000 113) to withdraw drive shaft.

Raw Material:

- 1 aluminum alloy square of 51 mm (2 in) x 305 mm (12 in).
- 2 aluminum rods of 28.5 mm (1-1/8 in) dia. x 30 mm (1-3/16 in).

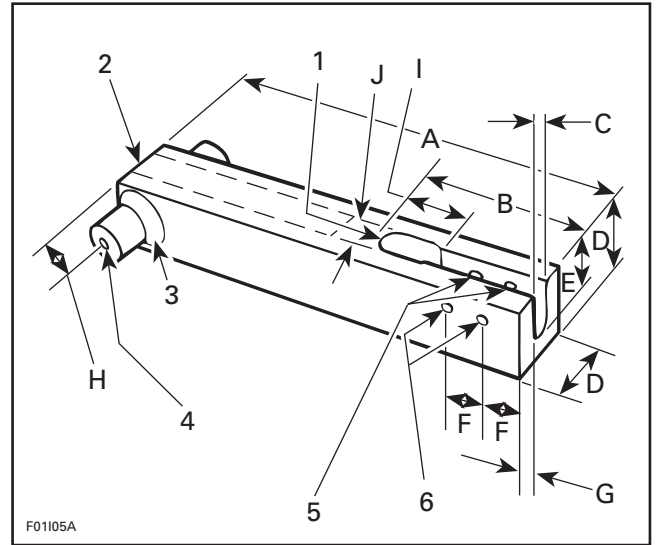

1. Use ball end mill for radius. This section of the slot should be 38 mm (1-15/32 in) deep
2. Drill 25 mm (1 in) hole in center to remove material
3. Weld all around
4. Drill 9 mm (11/32 in) hole
5. Drill through 9 mm (11/32 in)
6. Drill and tap 6 mm (1/4 in) holes
- A. 305 mm (12 in)
- B. 105 mm (4-1/8 in)
- C. 16 mm (5/8 in)
- D. 51 mm (2 in)
- E. 36 mm (1-25/64 in)
- F. 22 mm (7/8 in)
- G. 17 mm (43/64)
- H. 19 mm (3/4 in)
- I. 35 mm (1-3/8 in)
- J. 20.3 mm ± .18 (.800 in ± .007)

Mount on drive shaft puller the impeller housing remover; then, install assembly on drive shaft using screws.

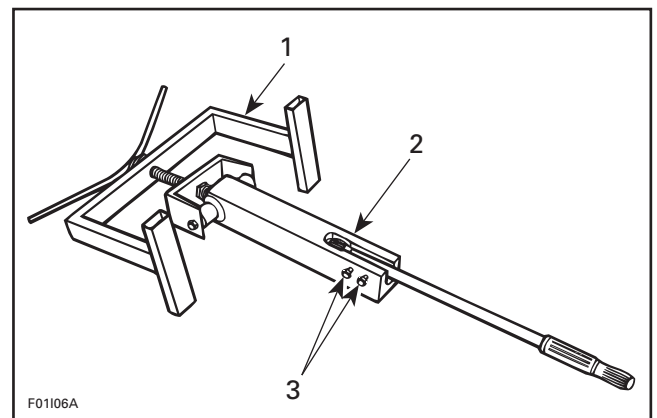

TYPICAL
 1. Impeller housing remover
 2. Drive shaft puller
 3. Screws

Section 08 PROPULSION SYSTEM

Sub-Section 03 (DRIVE SYSTEM)

▼ CAUTION

Be careful not to damage hull rear section or engine rubber mounts.

HX and XP Models

4, Rear Drive Shaft

Remove rear drive shaft.

NOTE: If the rear drive shaft is jammed, remove the seal carrier no. 12 and front drive shaft no. 7 if necessary.

7, Front Drive Shaft

Remove shock absorber from lower support. Refer to SUSPENSION 10-02 for proper procedure.

Remove bolt, lock nut and sleeve from support.

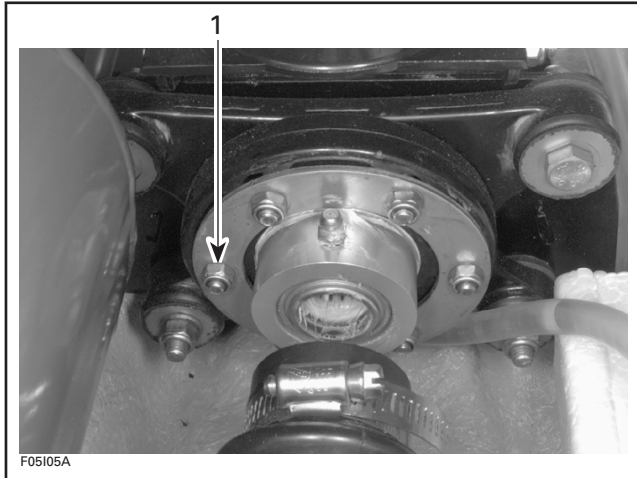

1. Nut (6)

All Models

9, Boot

Loosen gear clamp no. 8 holding boot no. 9, then carefully pull boot and carbon ring no. 10 from hull insert.

10, Carbon Ring

Loosen gear clamp no. 21 then pull carbon ring from boot no. 9.

11, PTO Flywheel

To remove PTO flywheel, the magneto flywheel must be locked. Refer to ENGINE 03-04 and follow the procedure to lock the magneto flywheel.

NOTE: Do not remove the magneto flywheel.

SP, GS, GSI, GTS and GTI Models

PTO flywheel is loosen using PTO flywheel remover (P/N 295 000 001).

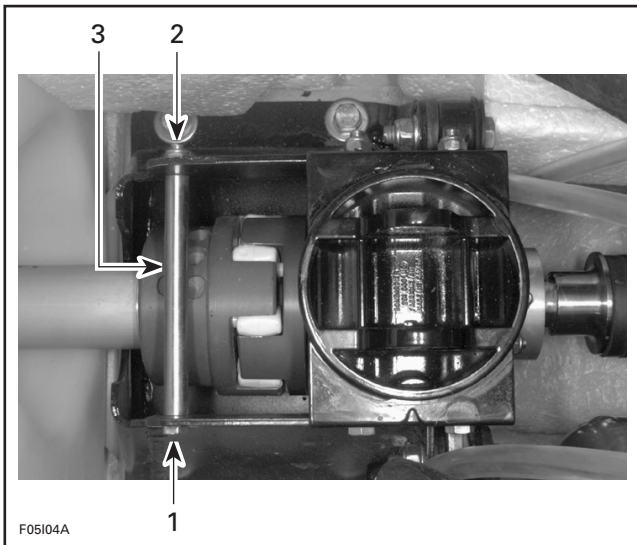

1. Bolt
2. Lock nut
3. Sleeve

Remove front drive shaft.

12, Seal Carrier

To remove the seal carrier from support, loosen the 6 nuts no. 19.

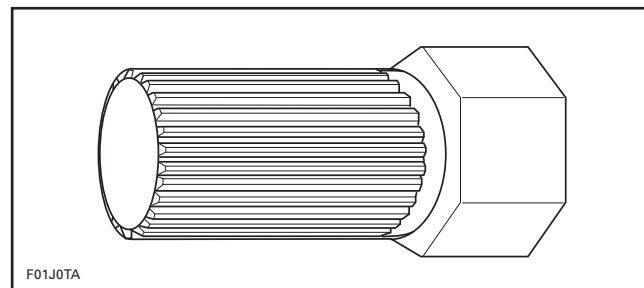

Insert special tool in PTO flywheel splines.

Section 08 PROPULSION SYSTEM
Sub-Section 03 (DRIVE SYSTEM)

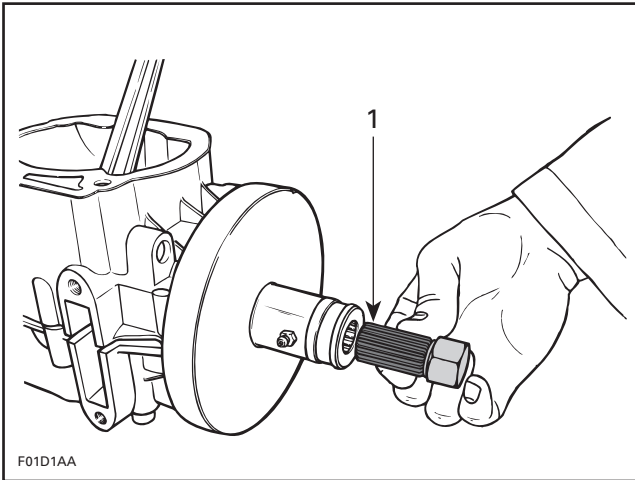

TYPICAL

1. PTO flywheel remover (P/N 295 000 001)

Using a suitable wrench or socket, unscrew PTO flywheel COUNTERCLOCKWISE when facing it and hold extension handle locking the magneto flywheel.

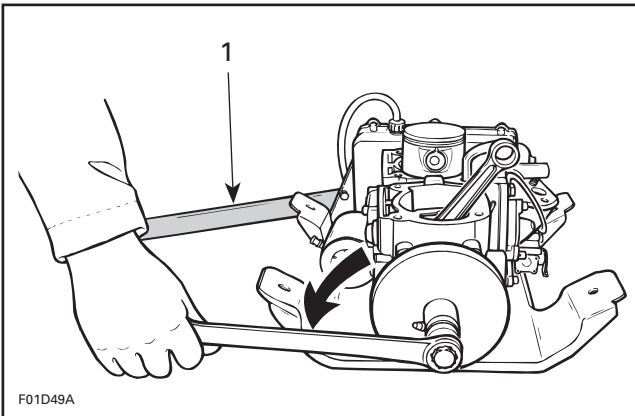

TYPICAL

1. Extension handle locking crankshaft

NOTE: When splines of PTO flywheel are worn out and special tool can not be used, proceed with the following alternate method.

Use a pipe wrench and install it on PTO flywheel as illustrated.

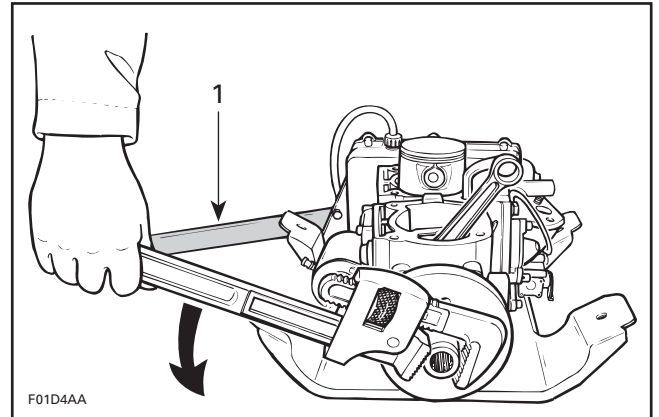

TYPICAL

1. Extension handle locking crankshaft

SPX, GSX, GTX, XP and HX Models

PTO flywheel is loosen using PTO flywheel remover (P/N 295 000 156).

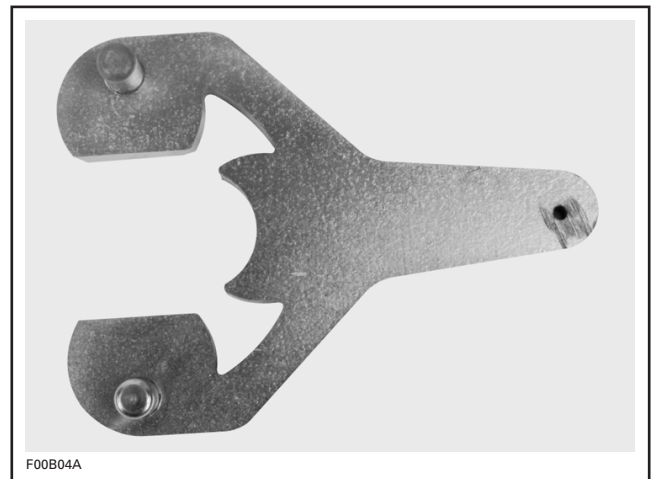

Install special tool.

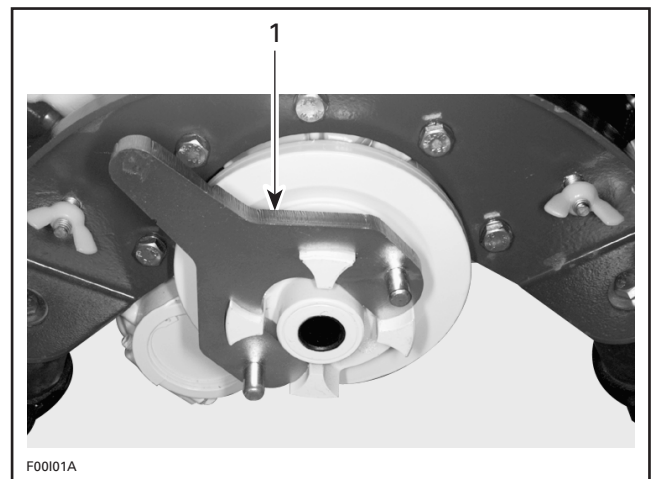

XP AND HX MODELS

1. PTO flywheel remover

Section 08 PROPULSION SYSTEM

Sub-Section 03 (DRIVE SYSTEM)

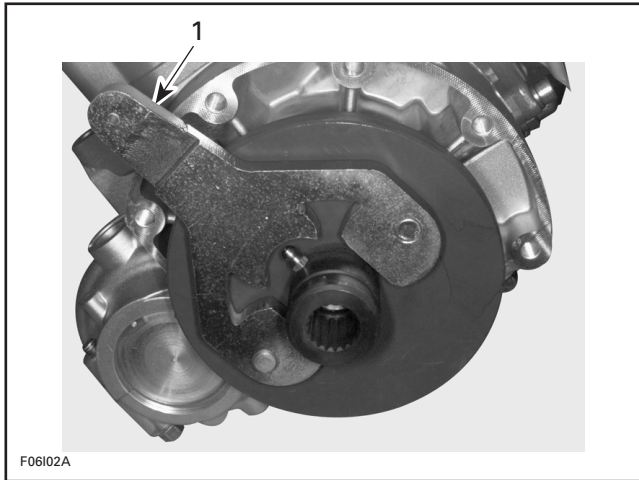

SPX, GSX AND GTX MODELS

1. PTO flywheel remover

Install the extension handle (P/N 295 000 125) on the PTO flywheel remover. Loosen PTO flywheel COUNTERCLOCKWISE when facing it.

DISASSEMBLY

HX and XP Models

13,14, Seal and Needle Bearing

Bearing and seals can be easily removed using the bearing/seal remover tool (P/N 295 000 144).

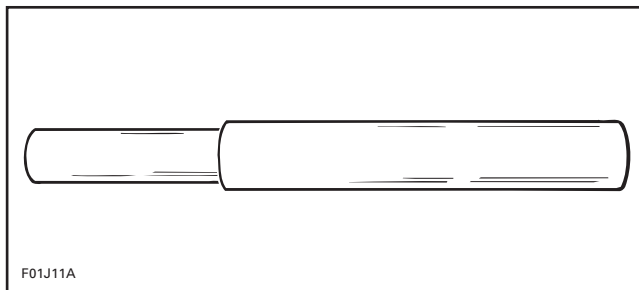

NOTE: The same tool is used for bearing and seal removal of jet pump.

Properly support seal carrier when removing seals and bearing.

PARTS INSPECTION

3, Drive Shaft

Inspect condition of splines.

Inspect condition of groove.

With your finger nail, feel contact surface of floating ring. If any irregular surface is found, renew drive shaft.

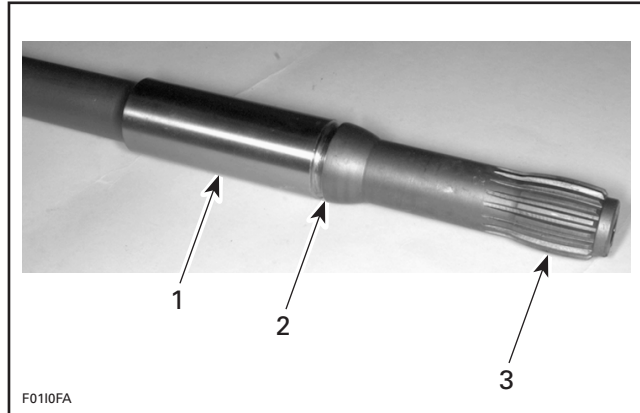

1. Floating ring contact surface
2. Groove condition
3. Splines condition

Excessive deflection could cause vibration and damage to drive shaft splines, impeller, flywheel or floating ring.

Place drive shaft on V-blocks and set-up a dial gauge in center of shaft. Slowly rotate shaft; difference between highest and lowest dial gauge reading is deflection. Refer to the following illustration.

Maximum permissible deflection is 0.5 mm (.020 in).

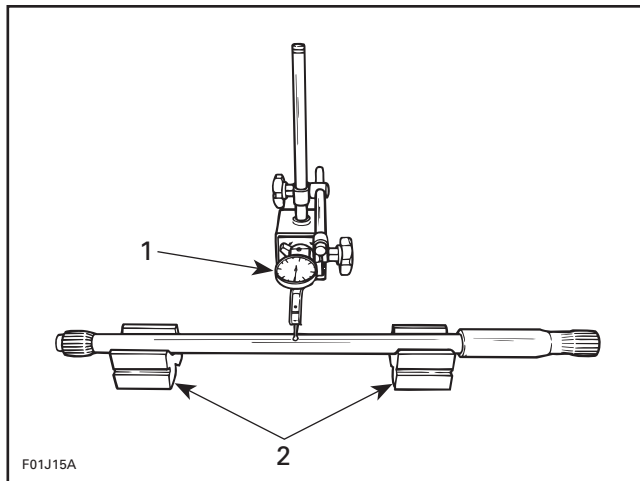

MEASURING DRIVE SHAFT DEFLECTION

1. Dial gauge
2. V-blocks

15, Damper

Visually inspect shape of dampers for deformation or other damage.

5,18, Floating Ring and O-ring

Inspect condition of O-rings and floating ring contact surface.

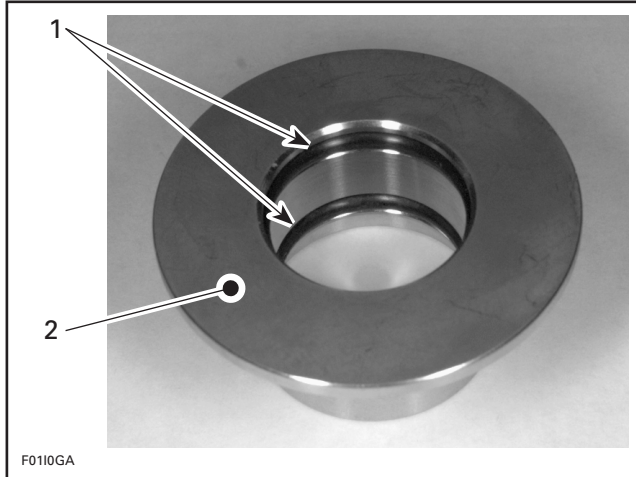

1. O-rings
2. Floating ring contact surface

6, O-ring

Check also condition of drive shaft O-ring. Replace as necessary.

All Models Except the XP and HX

11, PTO Flywheel

Inspect spline condition of PTO flywheel.

XP and HX Models Only

4,14, Drive Shaft and Needle Bearing

Inspect seal carrier needle bearing and its contact surface on drive shaft. Check parts for scoring, pitting, chipping or other evidence of wear.

ASSEMBLY

Assembly is essentially the reverse of disassembly procedure. However, pay particular attention to the following.

XP and HX Models Only

14, Needle Bearing

Properly support seal carrier when installing seals and bearing.

▼ CAUTION

Ensure to install stamped end of bearing (showing identification markings) first on tool. Never hammer the bearing into its housing.

Install bearing with the bearing/seal installer tool (P/N 295 000 107).

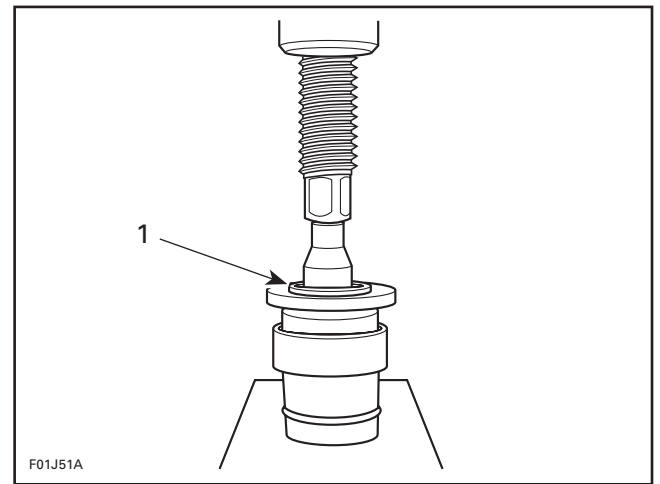

1. Press bearing in its housing

NOTE: Bearing can also be installed with the same driver used at disassembly. Center bearing in longitudinal axis of housing.

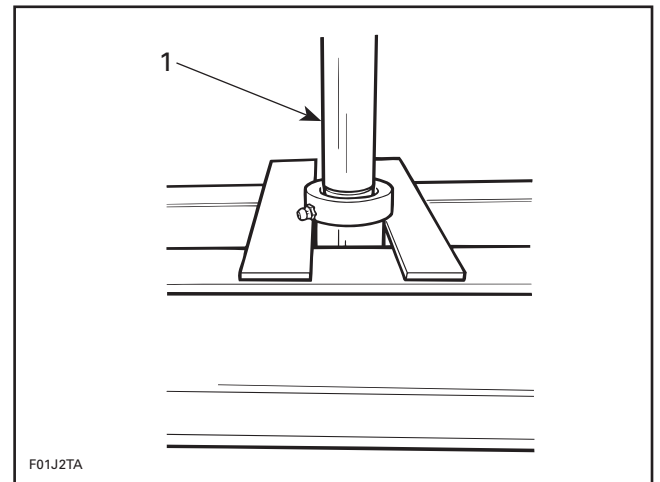

1. Push bearing centered in its housing

Section 08 PROPULSION SYSTEM

Sub-Section 03 (DRIVE SYSTEM)

13, Seal

Install double-lip seal with protector toward jet pump.

On both seals, raised edge of lip must be located outwards of seal carrier.

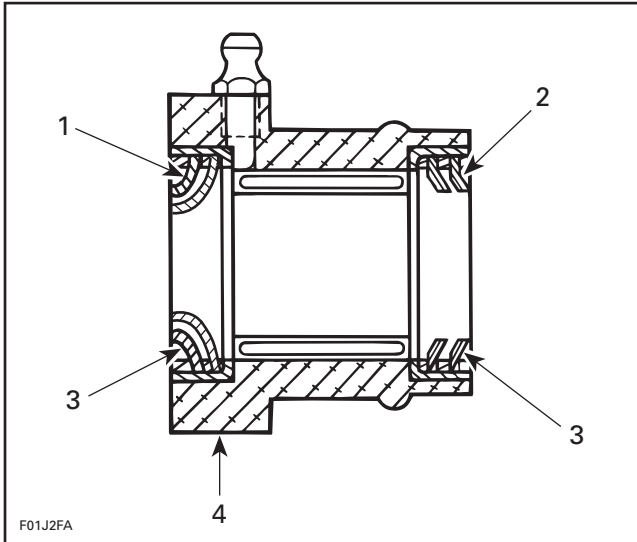

1. Double-lip seal toward engine
2. Double-lip seal with protector toward jet pump
3. Raised edge of lip outwards
4. Seal carrier

Apply Loctite 518 all around seals outside diameter.

Seals can be carefully installed in housing using bearing/seal installer tool (P/N 295 000 107).

Push seals until tool comes in contact with housing.

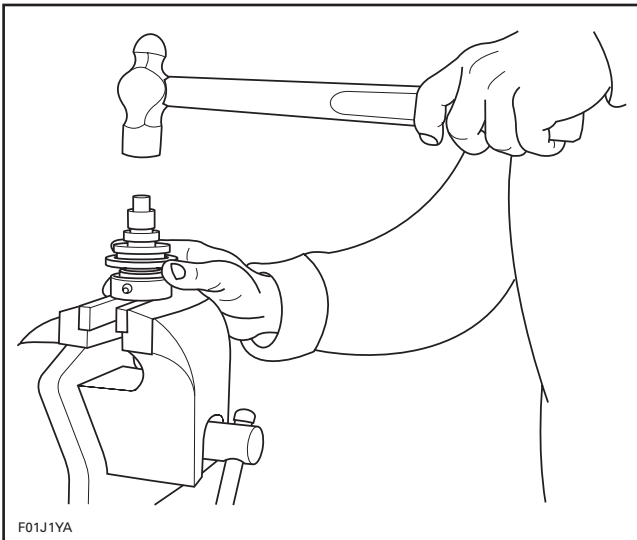

TYPICAL

Pack seals and bearing with synthetic grease (P/N 293 550 010).

12, Seal Carrier

Properly index flanges together.

Install seal carrier and hand tighten nuts only.

NOTE: Apply Loctite 242 (blue) on studs.

Install alignment tool at rear of watercraft.

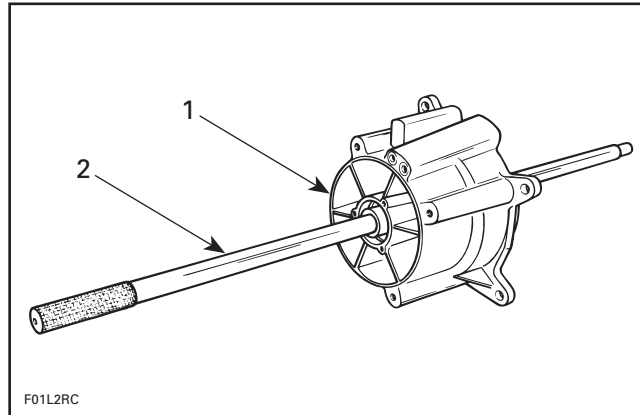

1. Housing (P/N 295 000 090)
2. Alignment shaft (P/N 295 000 093)

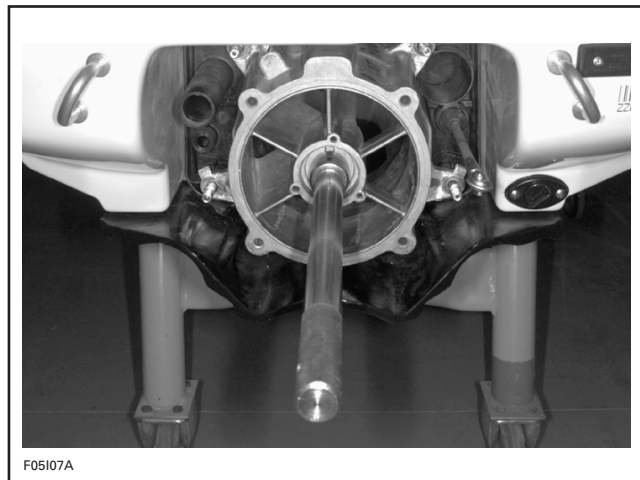

Carefully slide shaft through seal carrier.

Section 08 PROPULSION SYSTEM

Sub-Section 03 (DRIVE SYSTEM)

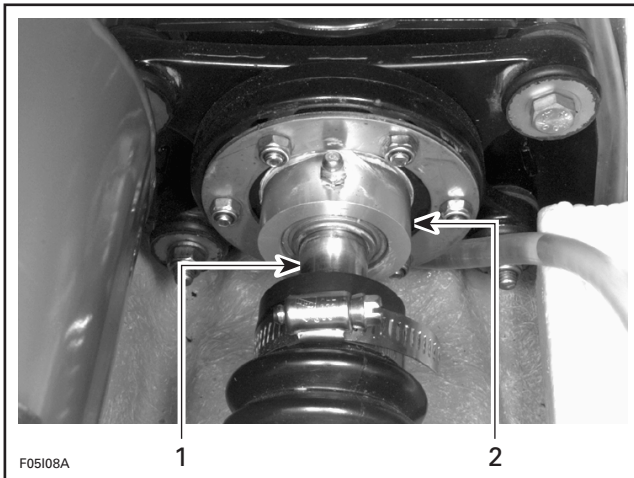

1. Alignment tool
2. Seal carrier

Torque seal carrier nuts **no. 19** to 7 N•m (62 lbf•in) in a criss-cross sequence as per following illustration.

NOTE: It is very important to tighten nuts of seal carrier in a criss-cross sequence to maintain its alignment.

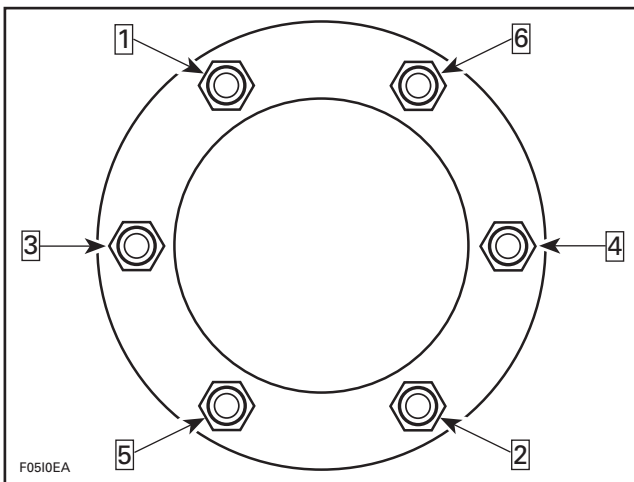

16,17, Damper and Bushing

Make sure to install dampers **no. 16** and bushings **no. 17** on front drive shaft **no. 8**.

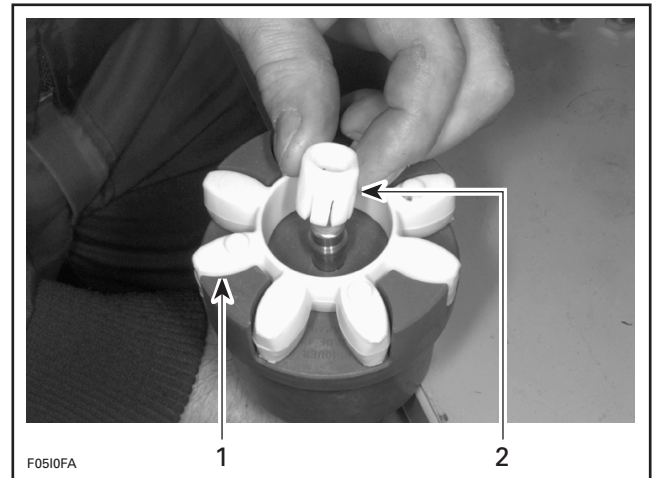

ENGINE SIDE SHOWN

1. Damper
2. Bushing

7,20, Front Drive Shaft and Coupler

Install front drive shaft **no. 7** and coupler **no. 20**.

4,15, Rear Drive Shaft and Damper

Install damper **no. 15** on rear drive shaft.

All Models Except the XP and HX

15, Damper

Install damper **no. 15** on drive shaft **no. 3**.

NOTE: Make sure dampers were not left in PTO flywheel or impeller.

Section 08 PROPULSION SYSTEM

Sub-Section 03 (DRIVE SYSTEM)

All Models

5,6, Floating Ring and O-ring

Position the O-ring no. 6 of the drive shaft in the flange of the floating ring no. 5.

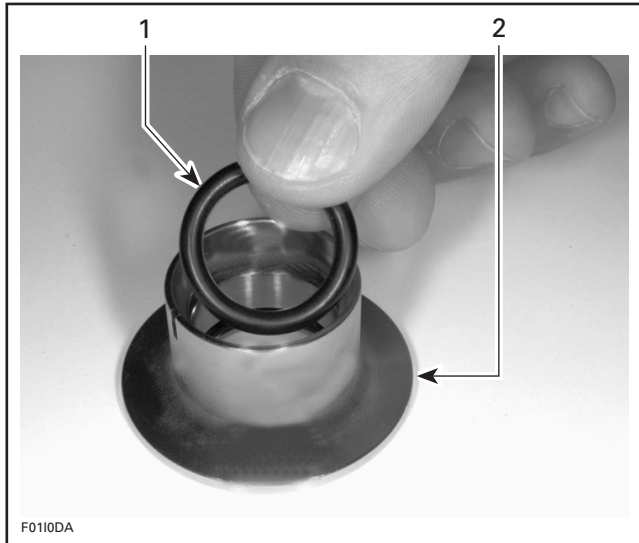

1. O-ring
2. Floating ring

Position the floating ring no. 5 between the carbon ring no. 10 and the PTO flywheel (seal carrier for the HX and XP models).

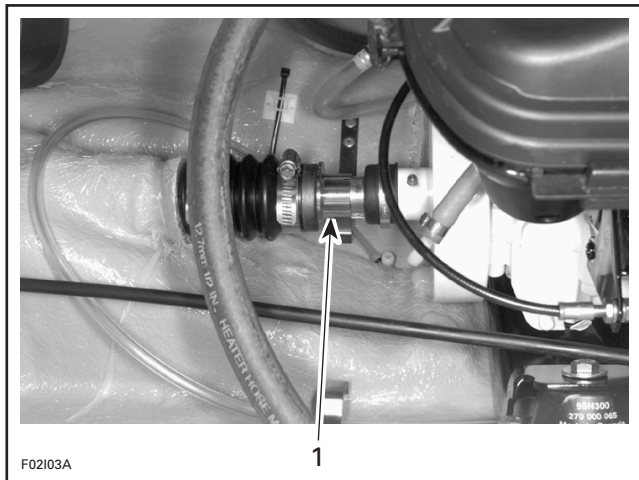

TYPICAL

1. Floating ring

All Models Except the XP and HX

3, Drive Shaft

Install drive shaft.

▼ CAUTION

Take care not to break the O-ring in the floating ring flange while inserting the drive shaft.

Engage drive shaft splines in PTO flywheel. Rotate shaft to properly index splines. Make sure boot is well positioned over shaft end.

XP and HX Models Only

4, Rear Drive Shaft

Install rear drive shaft.

▼ CAUTION

Take care not to break the O-ring in the floating ring flange while inserting the drive shaft.

Engage drive shaft splines in coupler no. 20. Rotate shaft to properly index splines.

All Models

Push the floating ring to compress the boot. Insert the O-ring in the drive shaft groove.

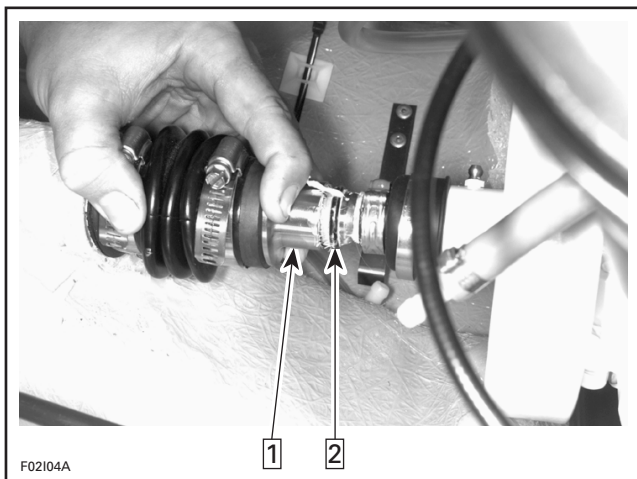

TYPICAL

- Step 1 : Push floating ring
Step 2 : Insert O-ring in the groove

Slide the floating ring onto the O-ring.

All Models Except the XP and HX

1, Large Clamp

Secure large clamp no. 1 as follows:

- Use pliers (P/N 295 000 069) as for removal.
- Manually engage holding hook in large window. This is a pre-clamping position only.

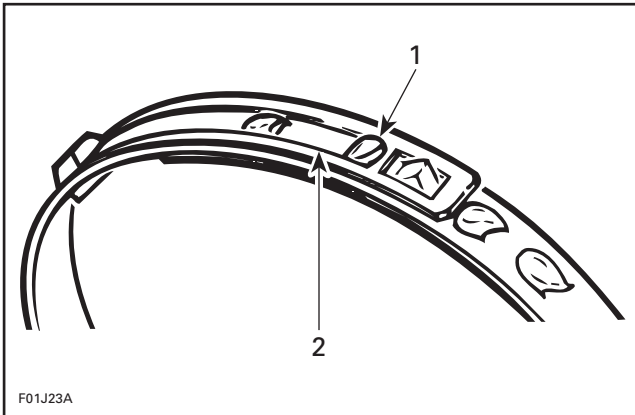

PRE-CLAMPING POSITION

1. Holding hook
2. Large window

- Insert pointed tips of pliers first in closing hooks.

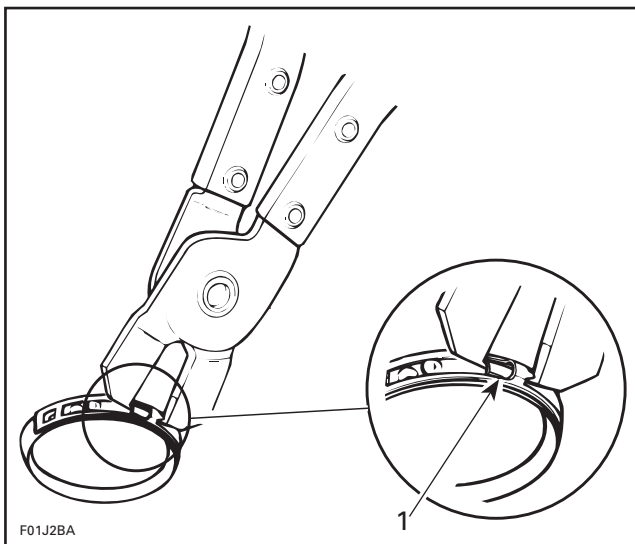

TYPICAL

1. Closing hooks

- Squeeze pliers. When both large and small windows are directly over the 2 locking hooks, press those windows down to engage hooks in windows.

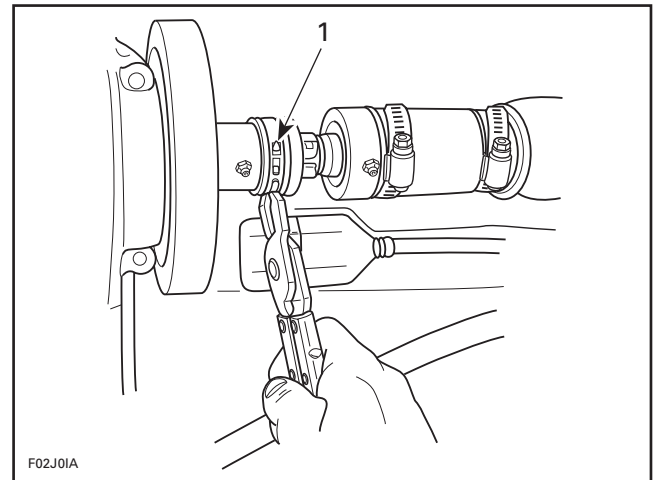

1. Press to engage hooks in windows

NOTE: At installation, clamp tail should be in opposite direction of engine rotation.

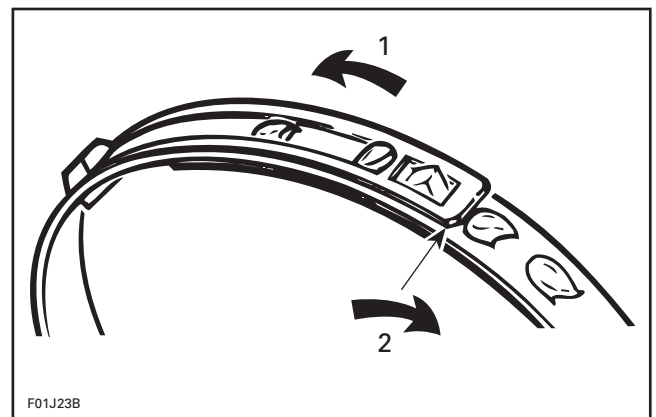

1. Engine rotation (counterclockwise)
2. Tail in opposite direction

Section 08 PROPULSION SYSTEM

Sub-Section 03 (DRIVE SYSTEM)

2, Small Clamp

To secure small clamp **no. 2**, place notch side of plier on clamp embossment and squeeze plier.

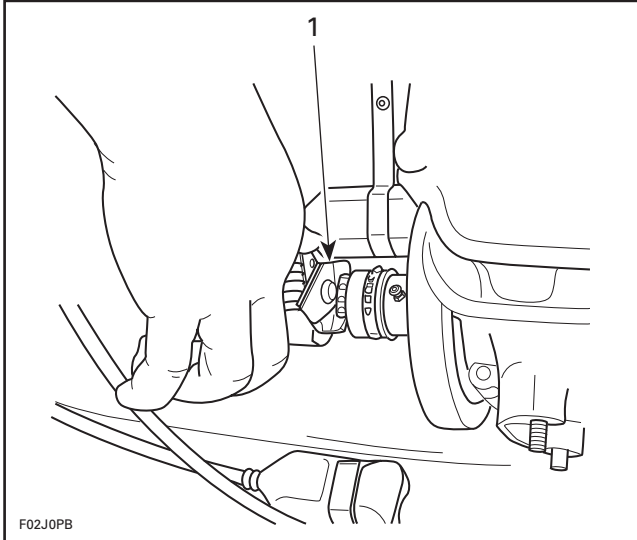

1. Squeeze plier

XP and HX Models

Lubricate mid bearing with synthetic grease (P/N 293 550 010).

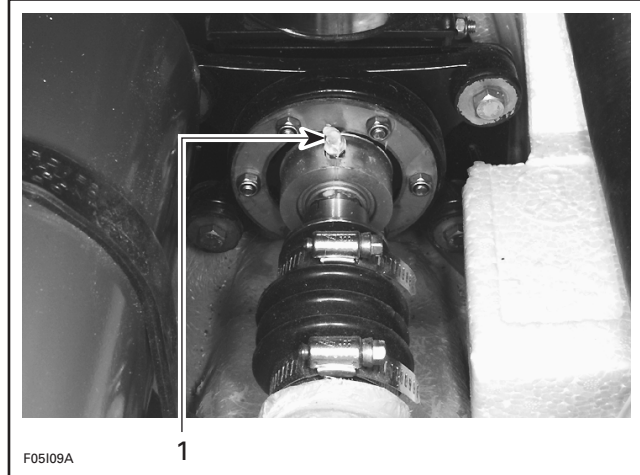

1. Grease fitting

LUBRICATION

All Models Except the XP and HX Models

Using a grease gun, carefully lubricate PTO fly-wheel with synthetic grease (P/N 293 550 010), until boot is just beginning to expand. At this point, immediately stop greasing.

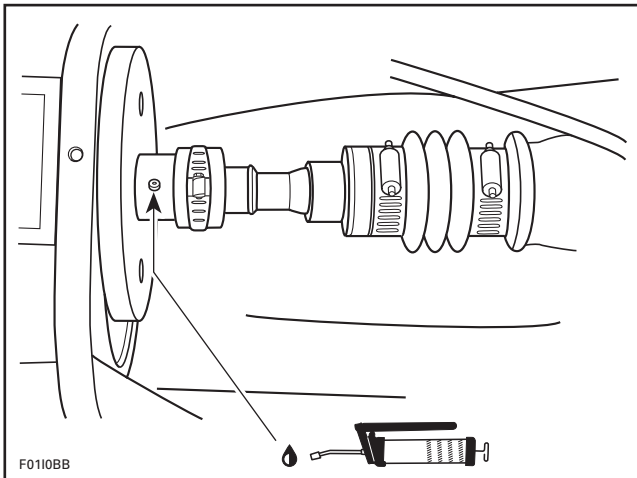

REVERSE SYSTEM

GTS Model

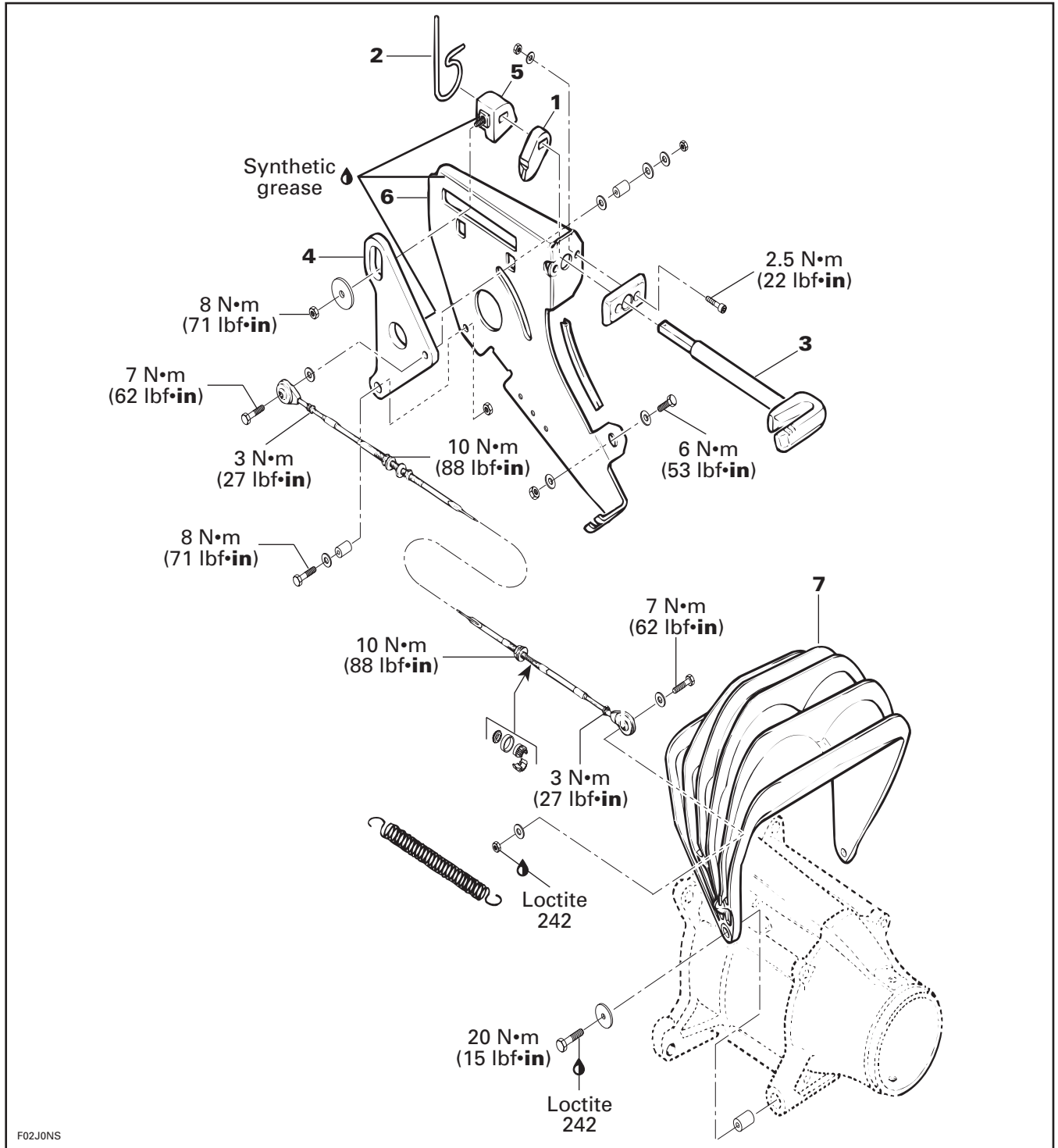

Section 08 PROPULSION SYSTEM

Sub-Section 04 (REVERSE SYSTEM)

GENERAL

It is not necessary to remove reverse system from watercraft for servicing. However reverse system removal is necessary to replace reverse support.

DISASSEMBLY

Remove storage tray from watercraft.

Press on vent tube upper part to enable to withdraw tube from body.

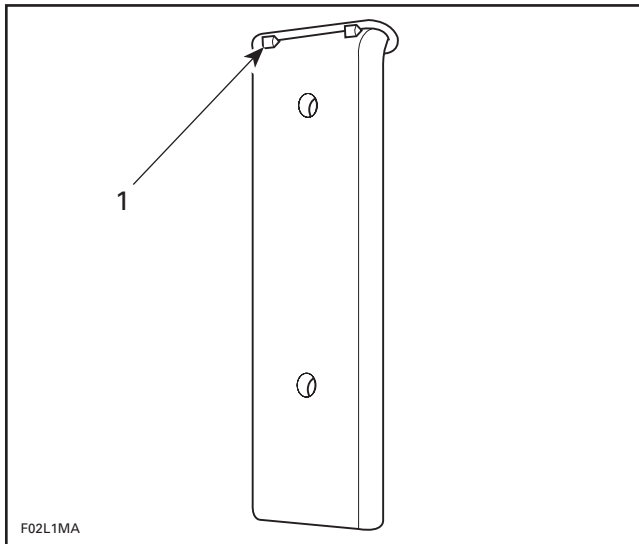

TYPICAL

1. Press on vent tube

3, Shift Lever

To remove shift lever, unhook spring no. 2 from sliding block no. 5 and pull spring from shift lever stem.

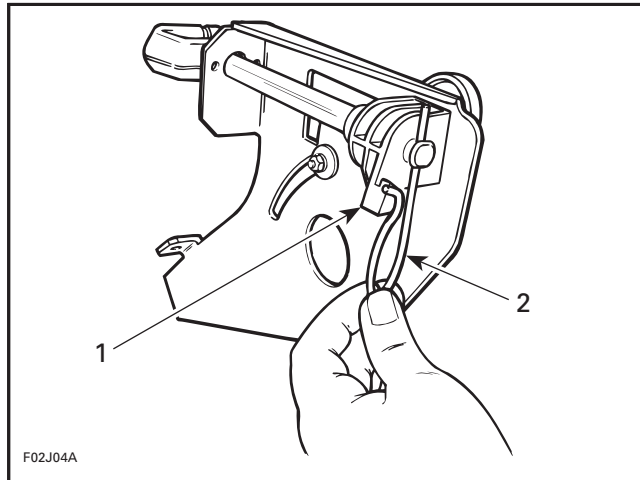

TYPICAL

1. Sliding block
2. Spring

Withdraw shift lever stem and locking lever no. 1 from sliding block no. 5, then slide off locking lever from stem.

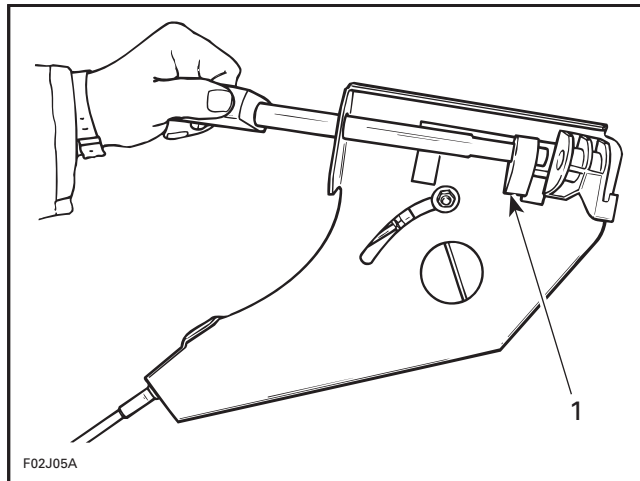

TYPICAL

1. Locking lever

4,5, Triangular Lever and Sliding Block

Remove screw, lock nut, washers and bushing holding reverse cable to triangular lever.

Remove lock nut and washer holding sliding block to triangular lever and to support.

Remove screw, lock nut, washer and bushing holding triangular lever to reverse support.

Section 08 PROPULSION SYSTEM
Sub-Section 04 (REVERSE SYSTEM)

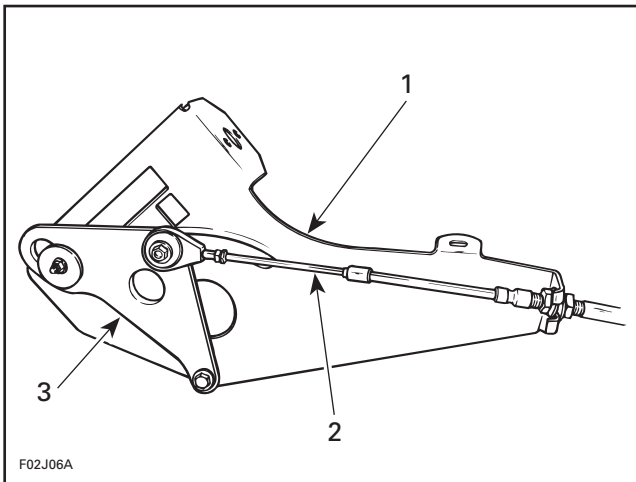

TYPICAL

1. Reverse support
2. Reverse cable
3. Triangular lever

6, Reverse Support

In order to have access to screw holding lower part of reverse support, remove front seat by pulling on each side to release it from body.

Remove screw, lock nut and washers holding lower part of support.

Remove reverse cable from support.

Remove 2 Allen screws, lock nut and washer holding guide plate and support.

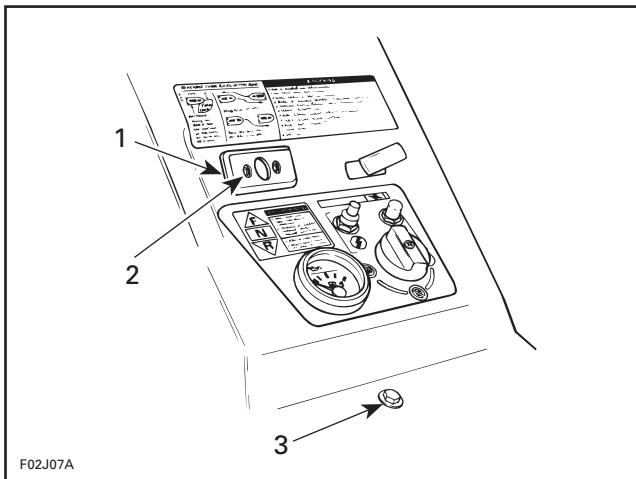

TYPICAL

1. Guide plate
2. Allen screw
3. Screw and washer

7, Reverse Gate

Unhook reverse gate springs and remove ball joint fasteners to release reverse cable from reverse gate.

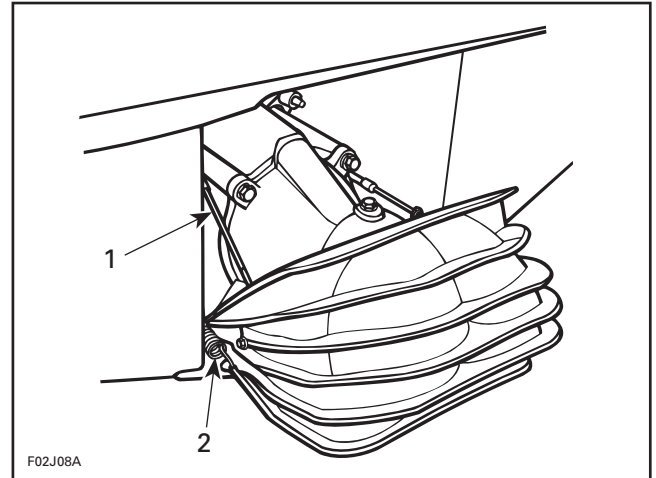

1. Reverse cable
2. Reverse gate spring (each side)

Unscrew reverse gate retaining screws from venturi housing, then remove gate.

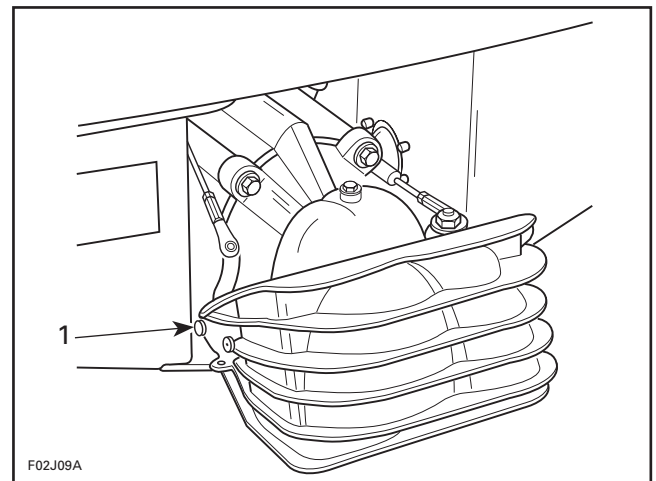

1. Screw (each side)

ASSEMBLY

Assembly is essentially the reverse of disassembly procedures. However pay particular attention to the following.

7, Reverse Gate

Install reverse gate with sleeve and washer. Apply Loctite 242 (blue) on threads and torque to 20 N•m (15 lbf•ft).

Section 08 PROPULSION SYSTEM

Sub-Section 04 (REVERSE SYSTEM)

▼ CAUTION

Always hook reverse gate springs in order to ease reverse gate operation.

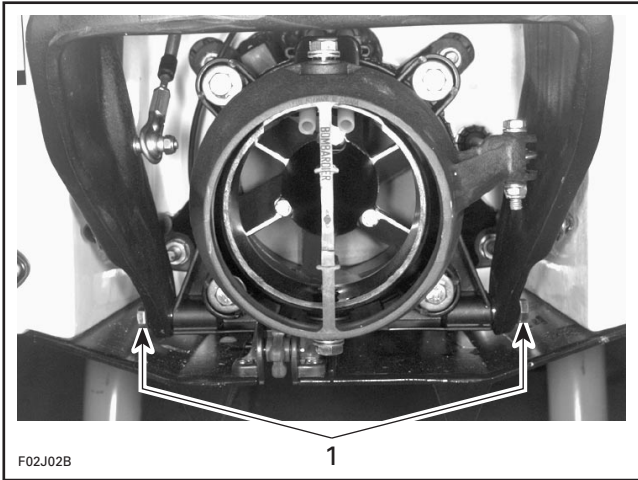

1. Screws, washers and sleeves

6, Reverse Support

For reverse support installation, torque screw to 8 N•m (71 lbf•in) and Allen screws to 2 N•m (18 lbf•in).

4,5, Triangular Lever and Sliding Block

Insert bushing in triangular lever and then install lever to reverse support.

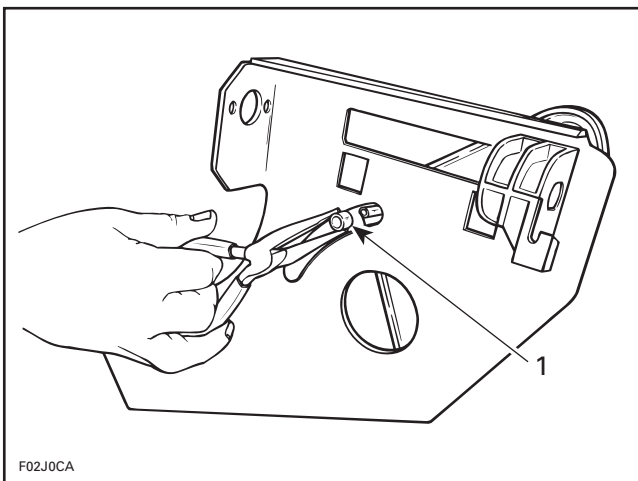

TYPICAL

1. Bushing

Install reverse cable to triangular lever with bushing, plastic washer(s) and flat washers.

Torque cable screw to 7 N•m (62 lbf•in).

Torque triangular lever screw to 8 N•m (71 lbf•in). Install sliding block to lever and torque nut to 8 N•m (71 lbf•in).

1,5, Locking Lever and Sliding Block

Insert locking lever end in support hole then align lever and sliding block holes.

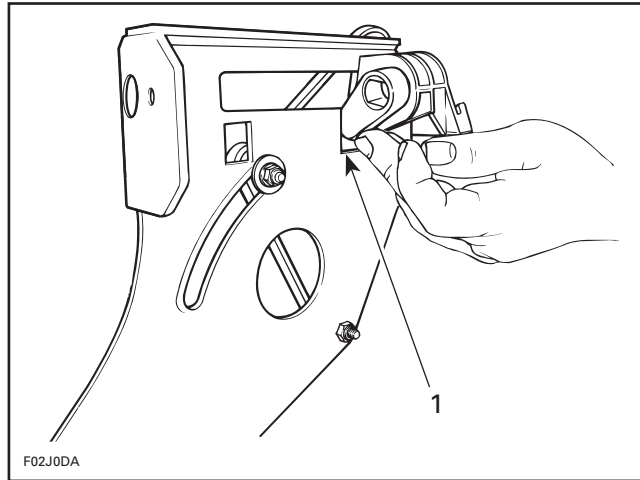

TYPICAL

1. Support hole

3, Shift Lever

NOTE: Always install shift lever with its open end facing left side of watercraft, then push shift lever stem through locking lever no. 1 and sliding block no. 5 holes.

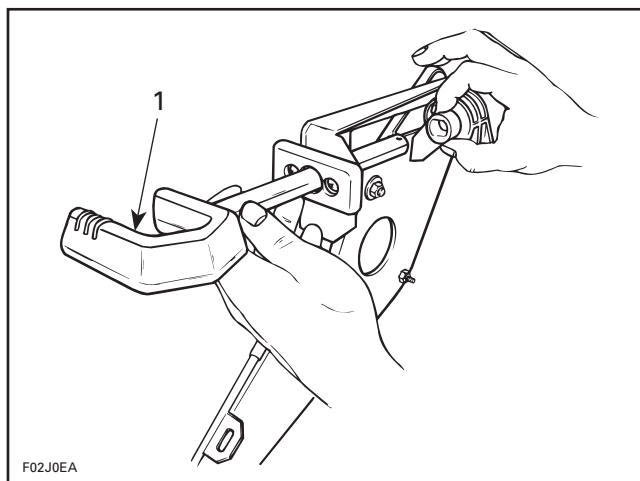

TYPICAL

1. Install shift lever as shown

2, Spring

Insert spring in lever stem hole and then install curved end in sliding block groove.

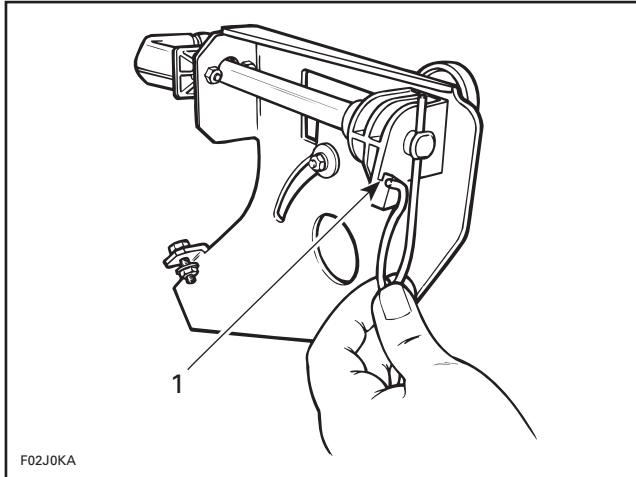

TYPICAL

1. Sliding block groove

Shift Lever Lubrication

Lubricate sliding block support sliding area and triangular lever with synthetic grease. Also, lubricate sliding washer and shift lever stem.

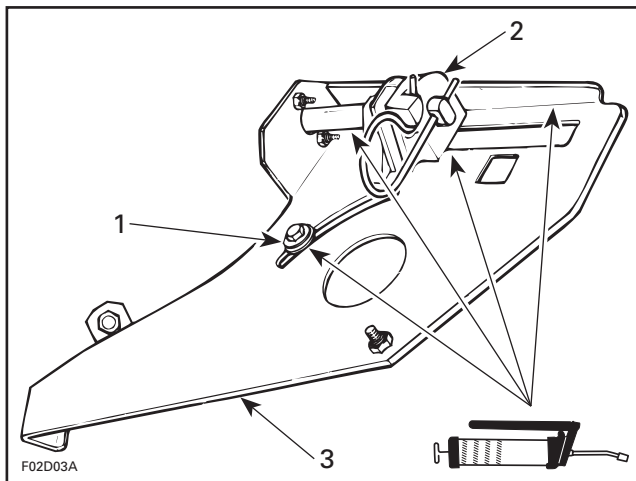

TYPICAL

1. Sliding washer
2. Sliding block
3. Support plate

ADJUSTMENTS

7, Reverse Gate

Position handlebar in a straight ahead position, nozzle should be parallel to rear of watercraft.

Using a square, set it to 129 ± 3 mm ($5\text{-}5/64 \pm 7/64$ in), then position square end at the top middle of nozzle.

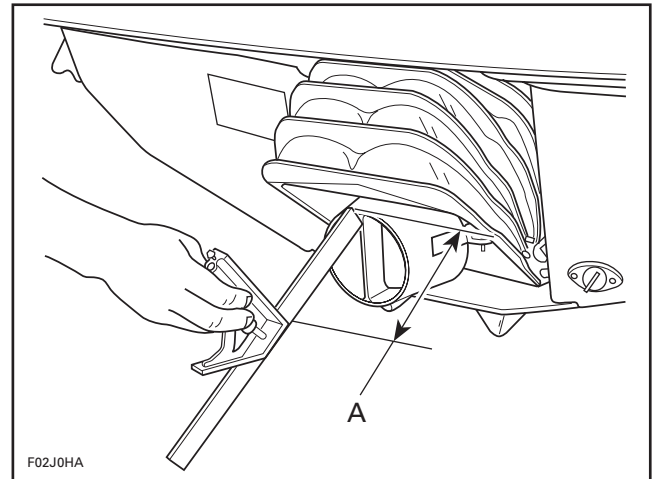

A. 129 ± 3 mm ($5\text{-}5/64 \pm 7/64$ in)

Pull shift lever in REVERSE position.

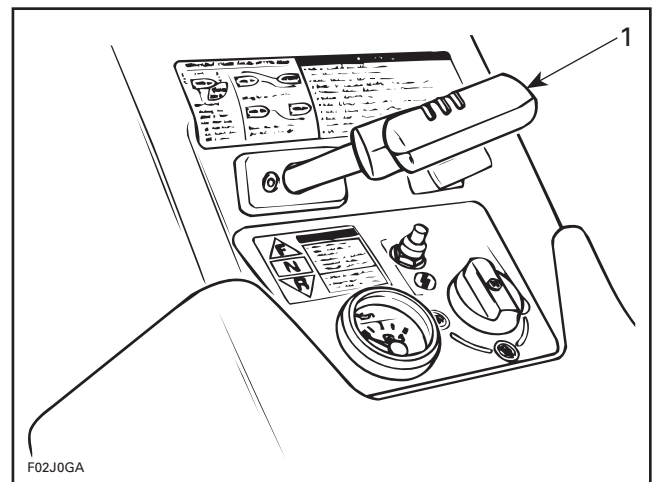

TYPICAL

1. Shift lever in REVERSE position

With the gate down to REVERSE position it should be at the specification.

NOTE: Push slightly on the gate in order to recover spring tension and to obtain proper position of the gate.

Section 08 PROPULSION SYSTEM

Sub-Section 04 (REVERSE SYSTEM)

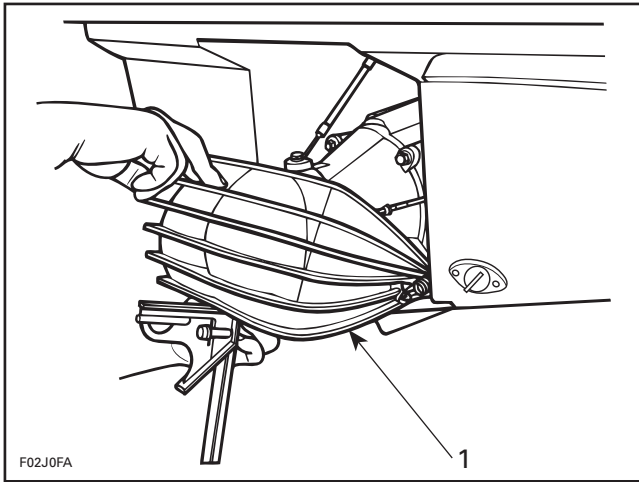

1. REVERSE position

If reverse gate needs to be readjusted, it can be done at support with adjustment nuts. Turn cable nuts to obtain position.

NOTE: If reverse gate adjustment is not done adequately, performance and steering control will be reduced at reverse position.

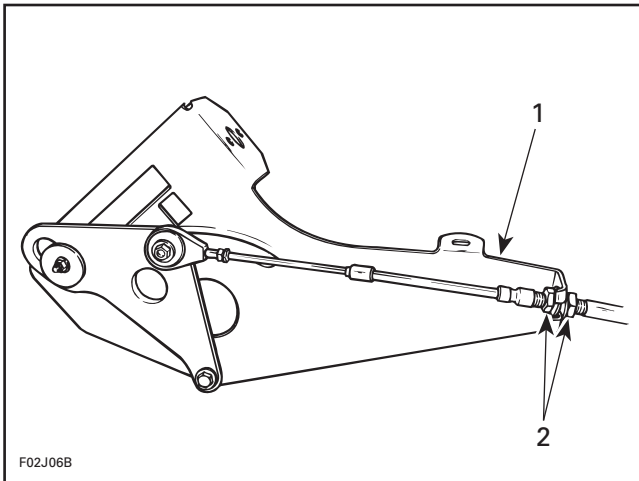

TYPICAL

1. Support
2. Adjustment nuts

Tighten adjustment nuts and recheck gate position.

Reinstall vent tube.

◆ WARNING

Vent tube must be in place to provide proper bilge ventilation.

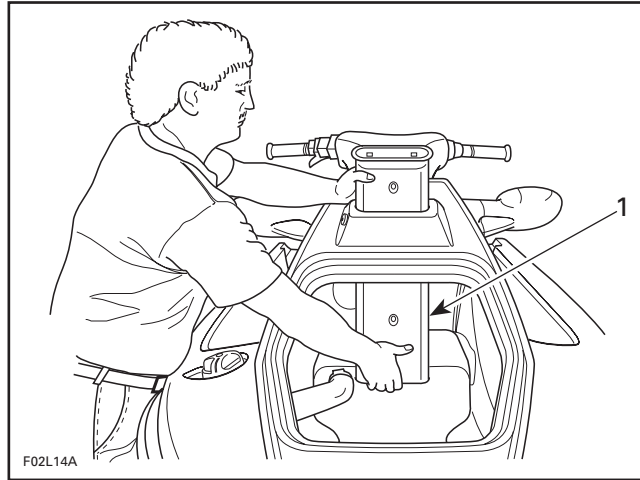

1. Install vent tube

Reinstall storage tray.

Section 08 PROPULSION SYSTEM

Sub-Section 04 (REVERSE SYSTEM)

GTI and GTX Models

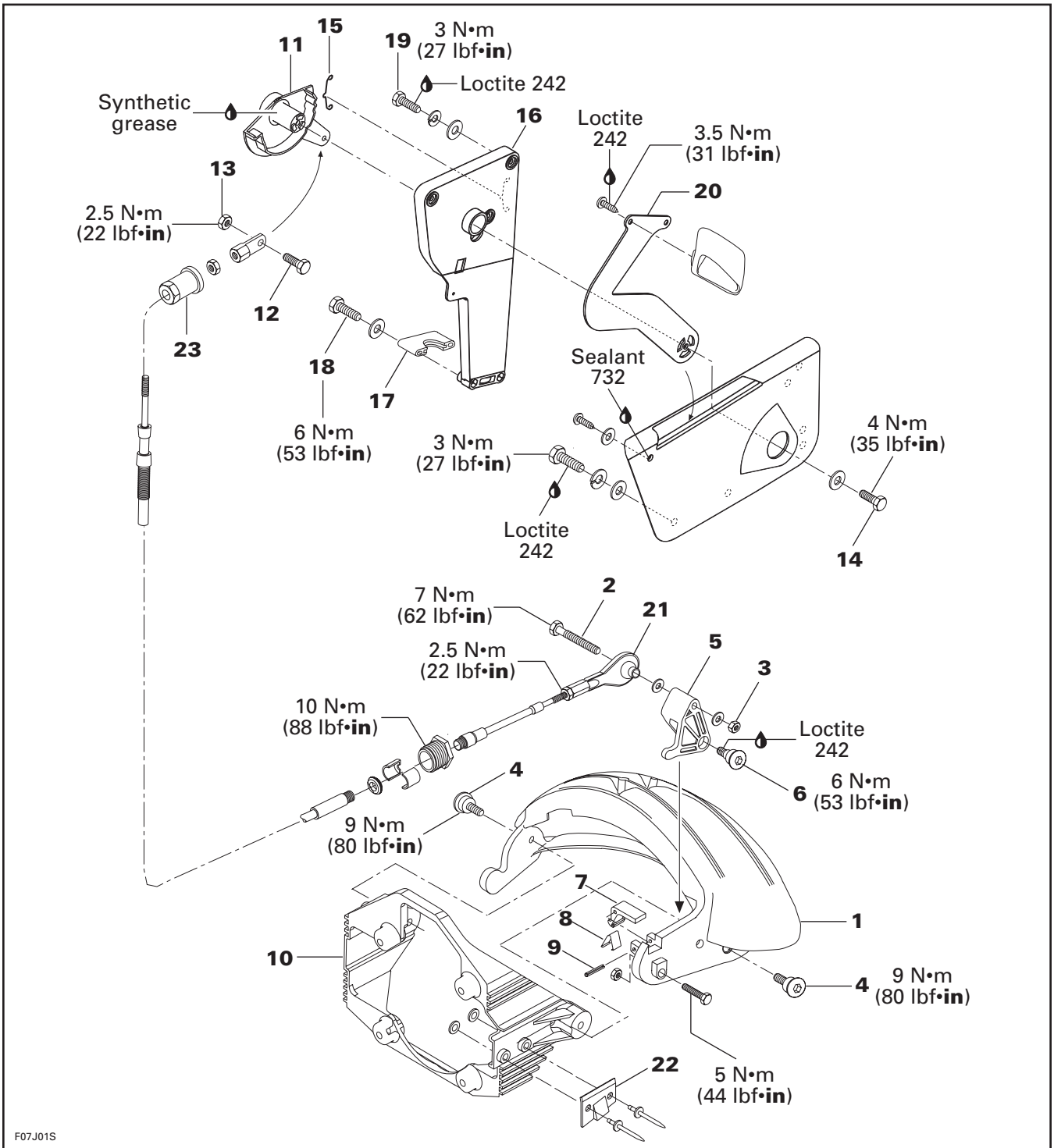

Section 08 PROPULSION SYSTEM

Sub-Section 04 (REVERSE SYSTEM)

DISASSEMBLY

1, Reverse Gate

Put shift lever in reverse position.

Disconnect reverse cable by loosening bolt no. 2 and lock nut no. 3 from cable lever.

Loosen 2 Allen screws no. 4 and remove reverse gate.

5, Cable Lever

Loosen Allen screw no. 6 and remove cable lever.

7,8, Pawl Lock and Spring

Remove roll pin no. 9.

10, Reverse Gate Support

Loosen 4 bolts which retain reverse gate support to venturi.

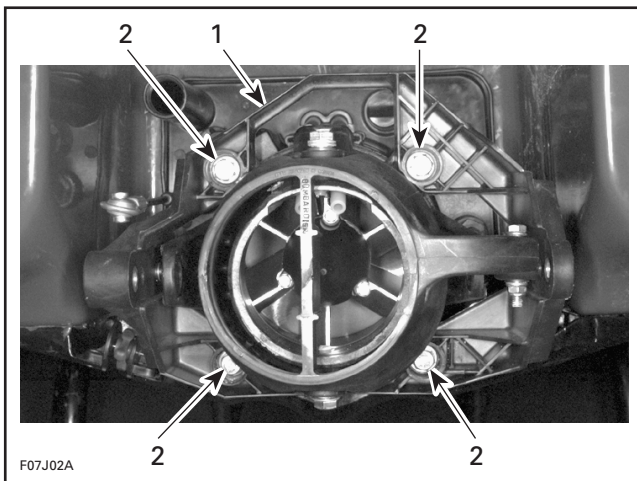

1. Support
2. Bolt

11, Interior Lever

Remove glove box.

Disconnect reverse cable by loosening bolt no. 12 and lock nut no. 13.

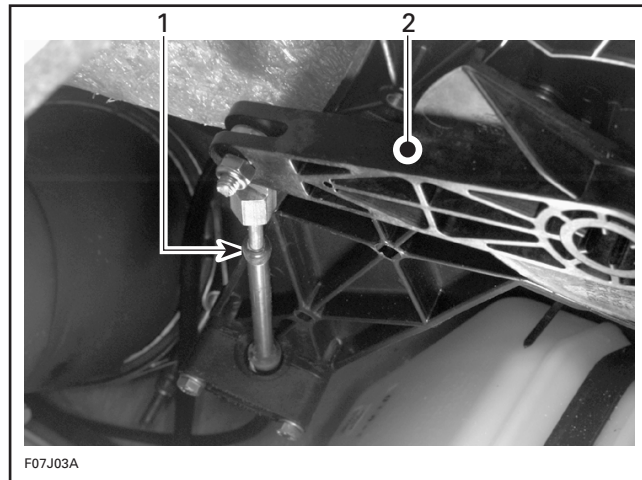

1. Reverse cable
2. Interior lever

Loosen bolt no. 14 retaining the interior lever.

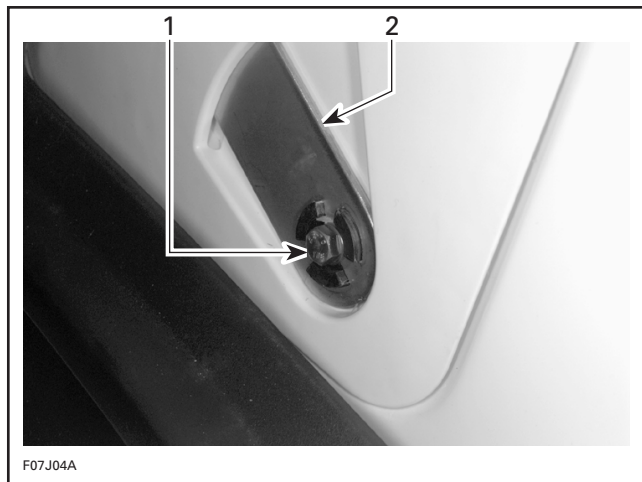

1. Bolt
2. Shift lever

Remove the interior lever and spring no. 15.

16, Reverse Cable Support

Remove retaining block no. 17 of reverse cable support by loosening bolts no. 18.

Loosen 3 bolts no. 19 retaining reverse cable support to body.

Remove reverse cable support.

INSPECTION

Visually inspect parts for wear or cracks. Replace parts as required.

ASSEMBLY

Assembly is essentially the reverse of disassembly procedures. However, pay particular attention to the following.

▼ CAUTION

Apply all specified torques and service products as per main illustration.

15, Spring

Make sure to properly installed spring in reverse cable support as per following illustration.

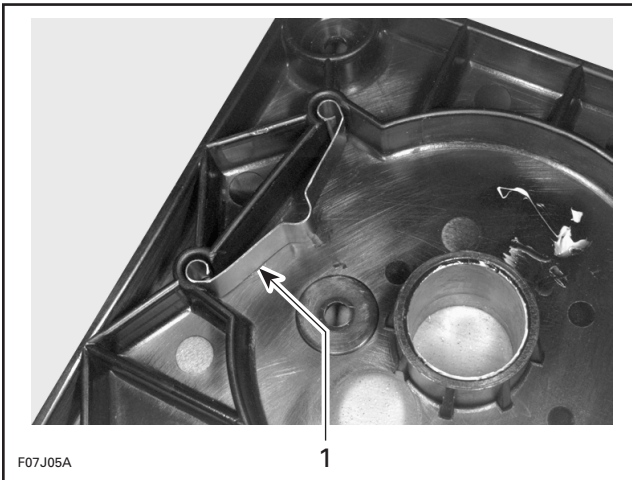

1. Spring

11,20, Interior Lever and Shift Lever

Install the interior lever in a rotating movement. Engage properly the interior lever tabs in the shift lever slots.

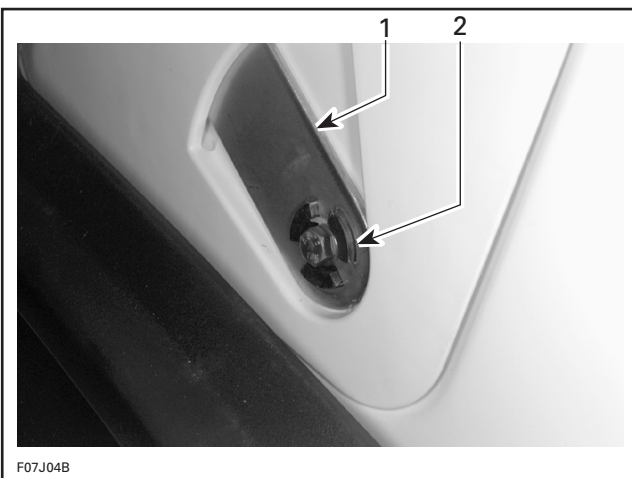

1. Shift lever
2. Interior lever tabs

Make sure the shift lever action is smooth and precise. Forward, neutral and reverse positions should be easy to select with a detent position between each.

8, Spring

Make sure spring is properly installed. One end of the spring is hooked in the pawl lock and the other end is retained by the stopper lock nut.

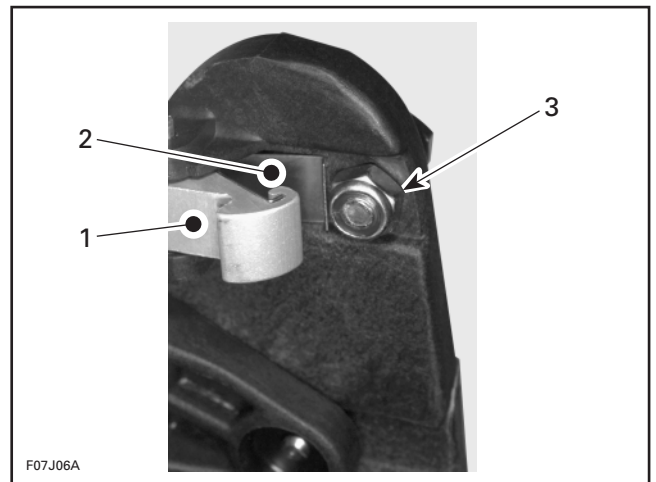

1. Pawl lock
2. Spring
3. Stopper lock nut

1, Reverse Gate

When installing the reverse gate, pay attention to position its lever behind the reverse gate support stopper.

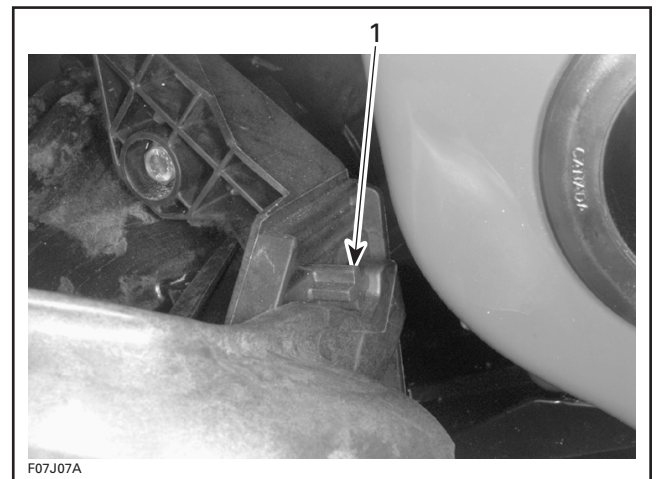

1. Stopper

Section 08 PROPULSION SYSTEM

Sub-Section 04 (REVERSE SYSTEM)

21, Reverse Cable

Install reverse cable to cable lever as per following illustration.

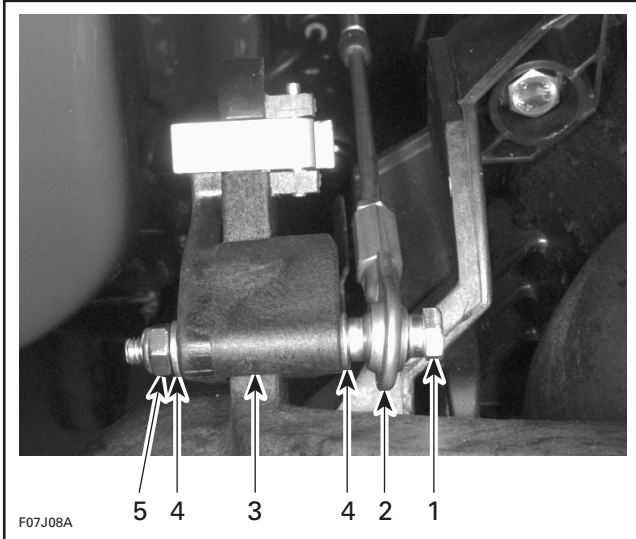

1. Bolt
2. Ball joint
3. Cable lever
4. Flat washer
5. Lock nut

▼ CAUTION

Ensure cable ball joint is parallel to cable lever ($90^\circ \pm 5^\circ$) to minimize tension on cable. Adjust as required.

ADJUSTMENT

Put shift lever in forward position.

Pull shift lever approximately 50 mm (2 in) and push it back slowly in forward position.

The pawl lock **no. 7** should be engaged in the anchor **no. 22**.

If not, adjust reverse cable. Loosen 2 bolts **no. 18** at reverse cable support **no. 16**. Turn adjustment nut **no. 23** as required.

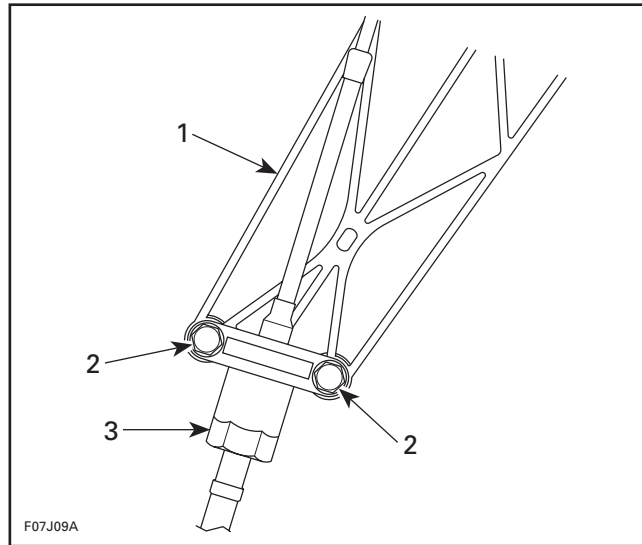

1. Reverse cable support
2. Loosen bolts
3. Adjustment nut

When adjustment is completed, there should be gap of 2 to 3 mm ($5/64$ to $7/64$ in) between handle and left cover.

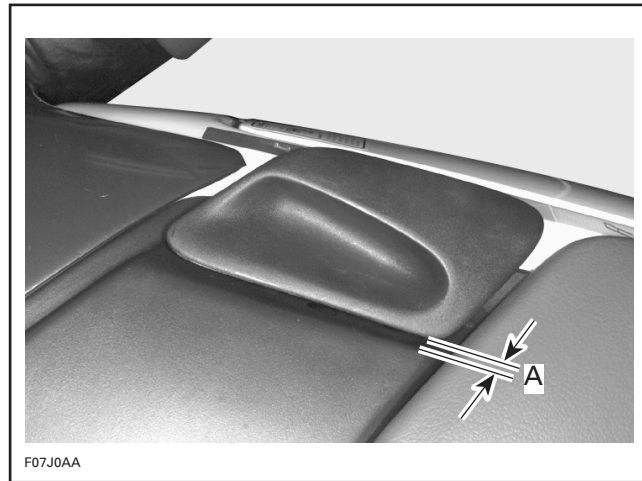

A. 2 to 3 mm ($5/64$ to $7/64$ in)

VARIABLE TRIM SYSTEM

MANUAL TRIM

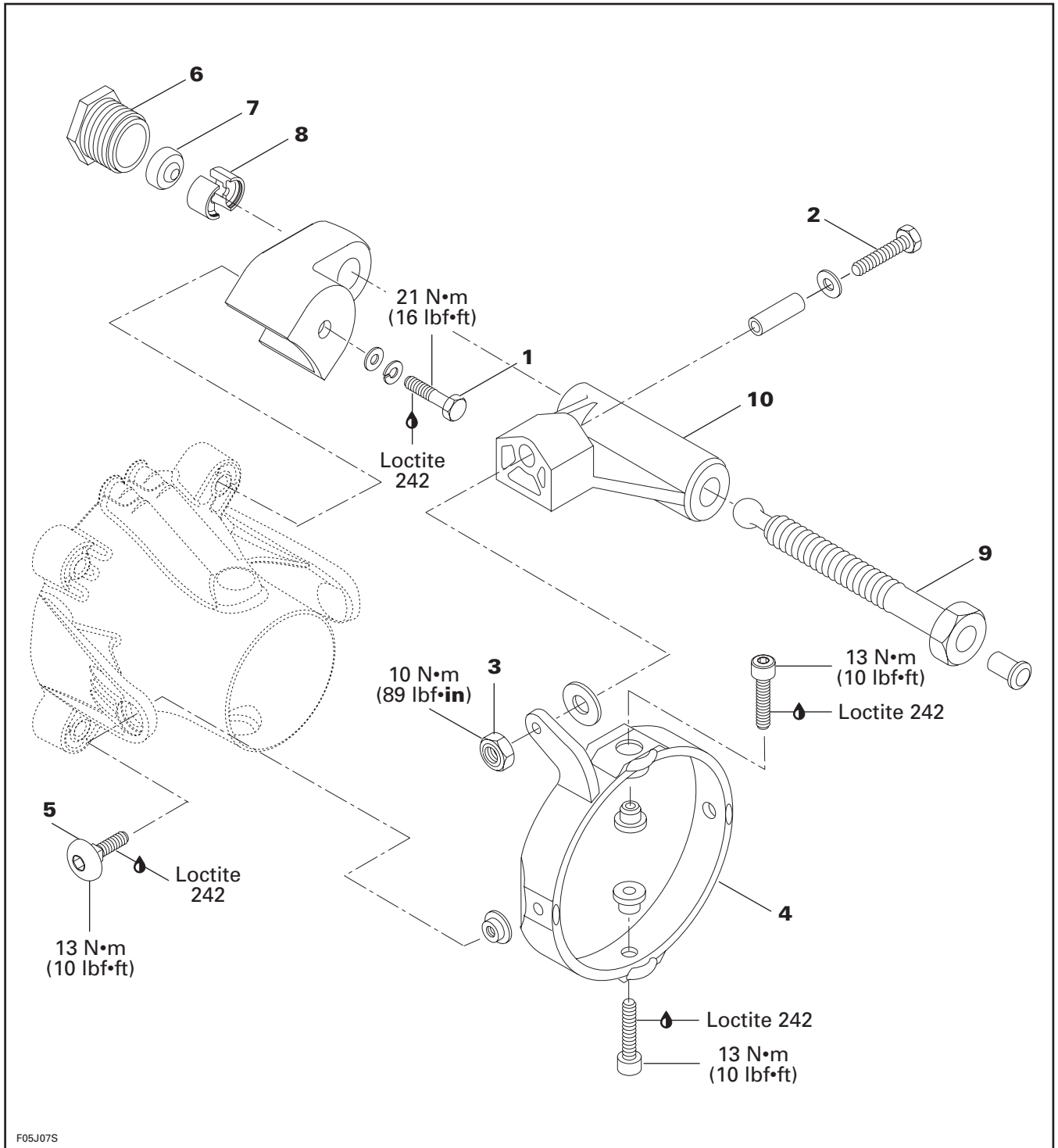

F05J07S

Section 08 PROPULSION SYSTEM

Sub-Section 05 (VARIABLE TRIM SYSTEM)

REMOVAL

Loosen screw **no. 1**, bolt **no. 2** and lock nut **no. 3** retaining support from trim ring.

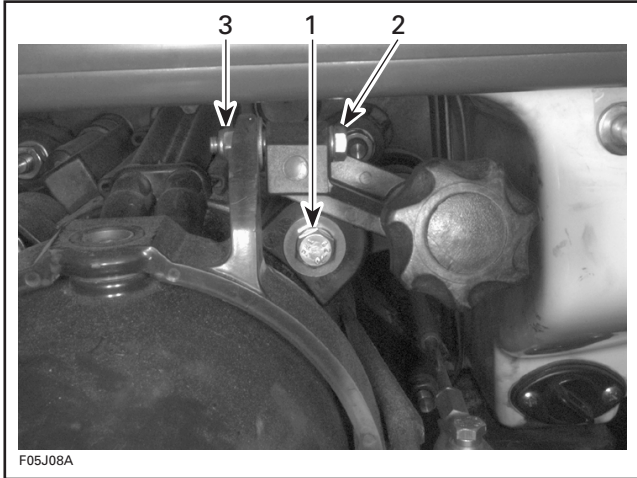

1. *Screw*
2. *Bolt*
3. *Lock nut*

Remove manual trim.

4, Trim Ring

To remove trim ring/nozzle assembly from venturi, loosen side screws **no. 5** of trim ring.

DISASSEMBLY

Loosen nut **no. 6** from support; then, remove rubber washer **no. 7** and half bushings **no. 8**.

Loosen adjustment screw **no. 9** to remove threaded pivot **no. 10**.

ASSEMBLY AND INSTALLATION

Assembly and installation are essentially the reverse of removal and disassembly procedures. For torque specifications and service products to be used, refer to the main illustration at the beginning of this sub-section.

ELECTRIC TRIM

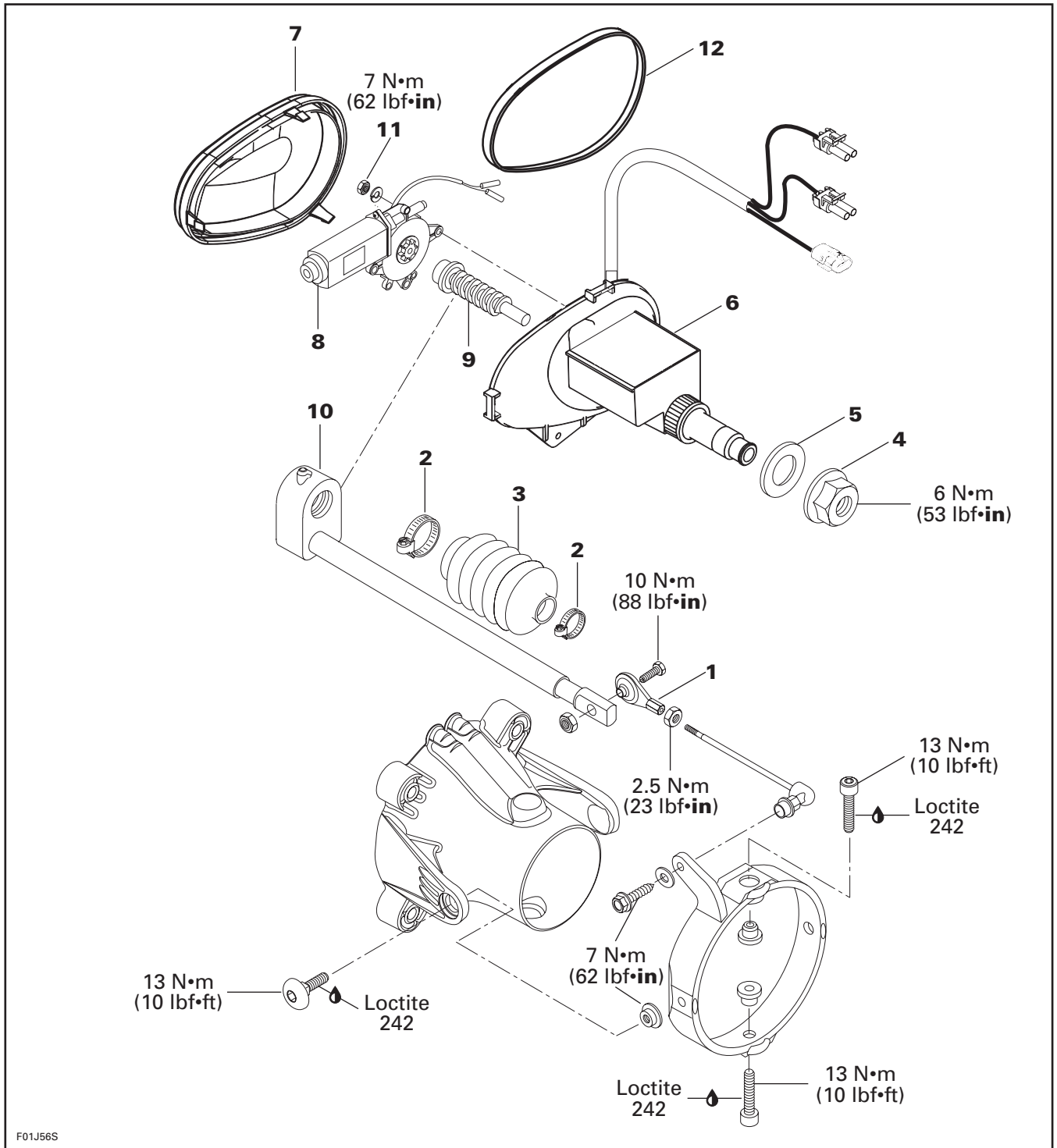

Section 08 PROPULSION SYSTEM

Sub-Section 05 (VARIABLE TRIM SYSTEM)

GENERAL

To test VTS control module, motor or switch, refer to ELECTRICAL SYSTEM 07-05.

REMOVAL

Disconnect ball joint **no. 1**.

Loosen gear clamps **no. 2**.

Remove boot **no. 3**.

To loosen nut **no. 4**, use VTS socket tool (P/N 295 000 133).

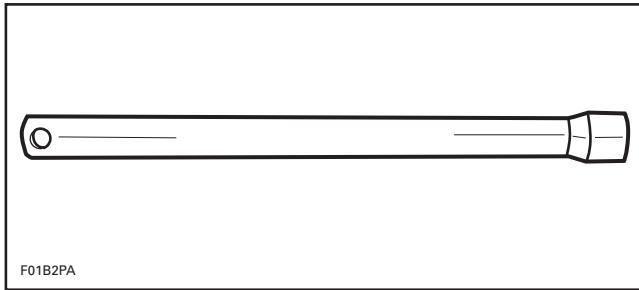

Pull out VTS assembly **no. 6** from bilge.

DISASSEMBLY

7, Cover

Remove VTS cover by pressing on tabs.

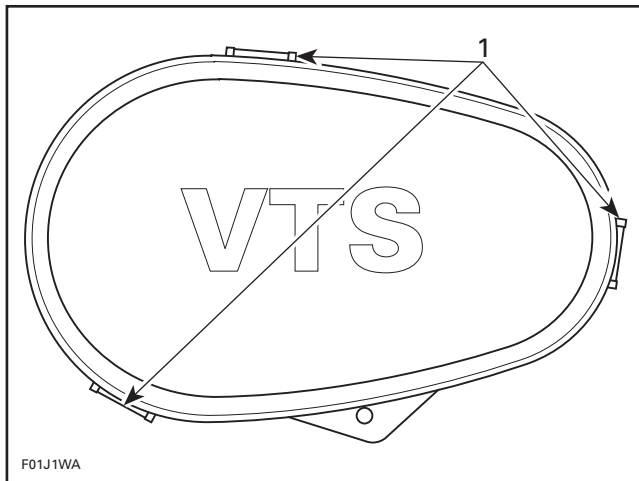

1. Press tabs to remove cover

8, Motor

Disconnect wires of motor.

Remove retaining nuts.

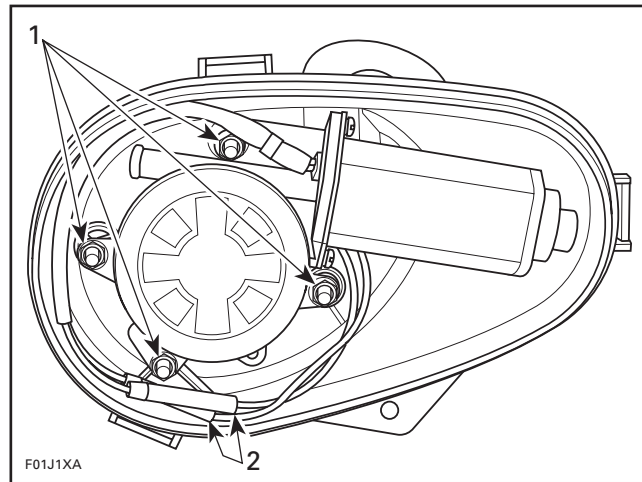

1. Remove nuts
2. Disconnect wires

Pull on motor to remove it.

9,10, Worm and Sliding Shaft

Simply pull on worm and sliding shaft in order to remove them.

INSPECTION

2, Boot

Make sure boot is in good condition. If it is cracked or teared, replace boot.

9, Worm

Inspect threads and splines of worm for wear. If worm replacement is necessary, renew also sliding shaft.

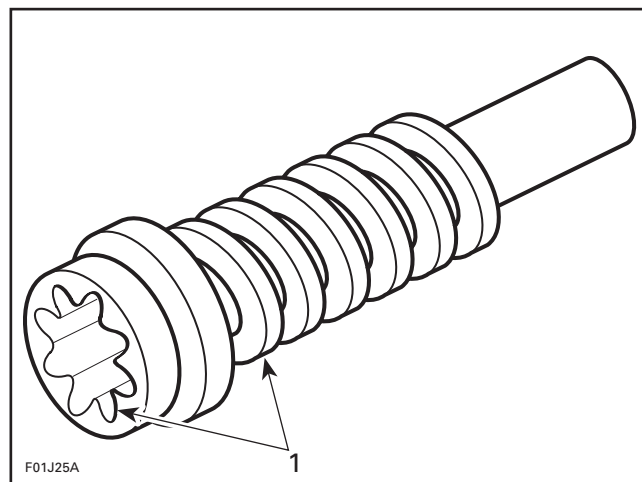

1. Inspect threads and splines

ASSEMBLY

Assembly is essentially the reverse of disassembly procedures. However pay particular attention to the following.

8,9,10, Motor, Worm and Sliding Shaft

Apply synthetic grease to worm.

Screw worm to sliding shaft.

Mesh worm splines to gear of motor.

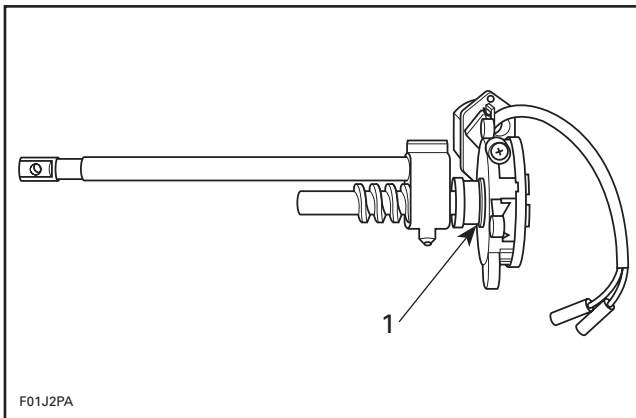

1. Mesh worm spline to gear of motor

Install motor, worm and sliding shaft in VTS housing.

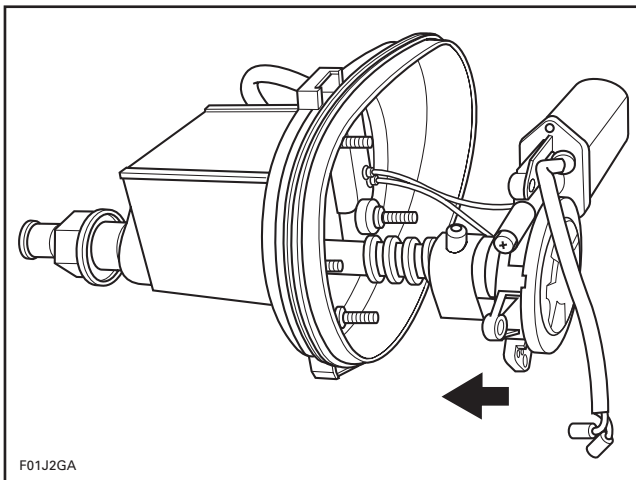

Tighten nuts **no. 11** of motor to 7 N•m (62 lbf•in).
Connect wires of motor.

▼ CAUTION

Make sure wire color codes match.

Install cover **no. 7**.

NOTE: Make sure seal **no. 12** is in place.

INSTALLATION

Installation is essentially the reverse of removal procedures. However pay particular attention to the following.

4,5, Nut and Seal

Place seal on nut. Make sure seal lips are facing toward hull.

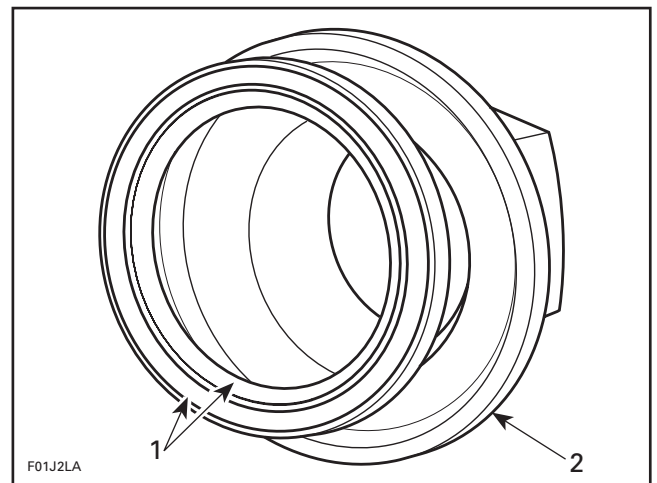

1. Seal lips facing hull
2. Nut

Install nut with seal and torque to 13 N•m (10 lbf•ft) using the VTS socket tool.

1, Ball Joint

SPX and XP Models

Install ball joint on **RIGHT** side of sliding shaft.
Torque fasteners to 10 N•m (88 lbf•in).

NOTE: Install boot on sliding shaft before securing ball joint.

GSI and GSX Models

Install ball joint on **LEFT** side of sliding shaft.
Torque fasteners to 10 N•m (88 lbf•in).

NOTE: Install boot on sliding shaft before securing ball joint.

Section 08 PROPULSION SYSTEM

Sub-Section 05 (VARIABLE TRIM SYSTEM)

ADJUSTMENT

Push on VTS button up position until motor stops. When the nozzle is up (8°), nozzle edge must not interfere with venturi (there should be a gap of 1 mm (.039 in)).

NOTE: Activate timer to be able to position VTS.

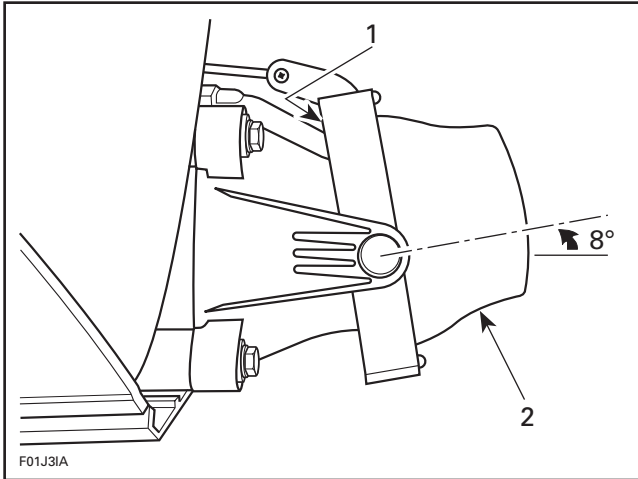

1. No interference
2. Nozzle up

If an adjustment is necessary, loosen jam nut of ball joint at link rod. Turn adjustment nut of ball joint to obtain the desired gap between trim ring and venturi.

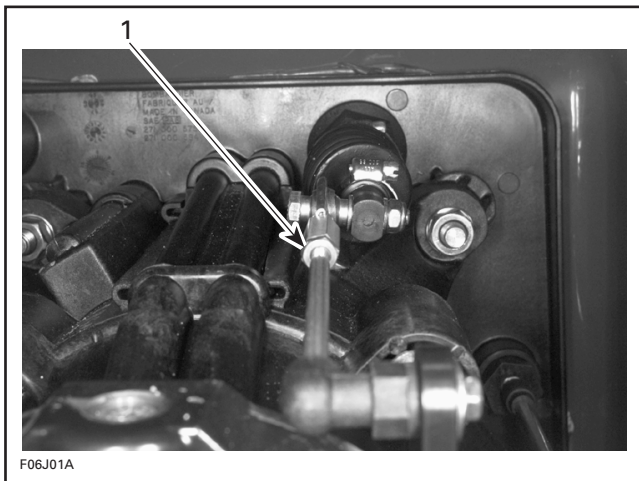

TYPICAL — GSX MODEL SHOWN

1. Turn adjustment nut of ball joint

Tighten jam nut of ball joint to $2.5 \text{ N}\cdot\text{m}$ ($23 \text{ lbf}\cdot\text{in}$) when adjustment is completed.

TABLE OF CONTENTS

SP AND SPX MODELS	09-02-1
REMOVAL AND INSTALLATION	09-02-2
STEERING ALIGNMENT	09-02-5
<hr/>	
GTS MODEL	09-03-1
REMOVAL AND INSTALLATION	09-03-2
STEERING ALIGNMENT	09-03-5
<hr/>	
GS, GSI, GSX, GTI AND GTX MODELS	09-04-1
DISASSEMBLY.....	09-04-2
ASSEMBLY.....	09-04-4
STEERING ALIGNMENT	09-04-5
<hr/>	
HX AND XP MODELS	09-05-1
REMOVAL	09-05-2
DISASSEMBLY.....	09-05-3
ASSEMBLY AND INSTALLATION.....	09-05-3
STEERING ALIGNMENT	09-05-5
<hr/>	
ALIGNMENT	09-06-1

SP AND SPX MODELS

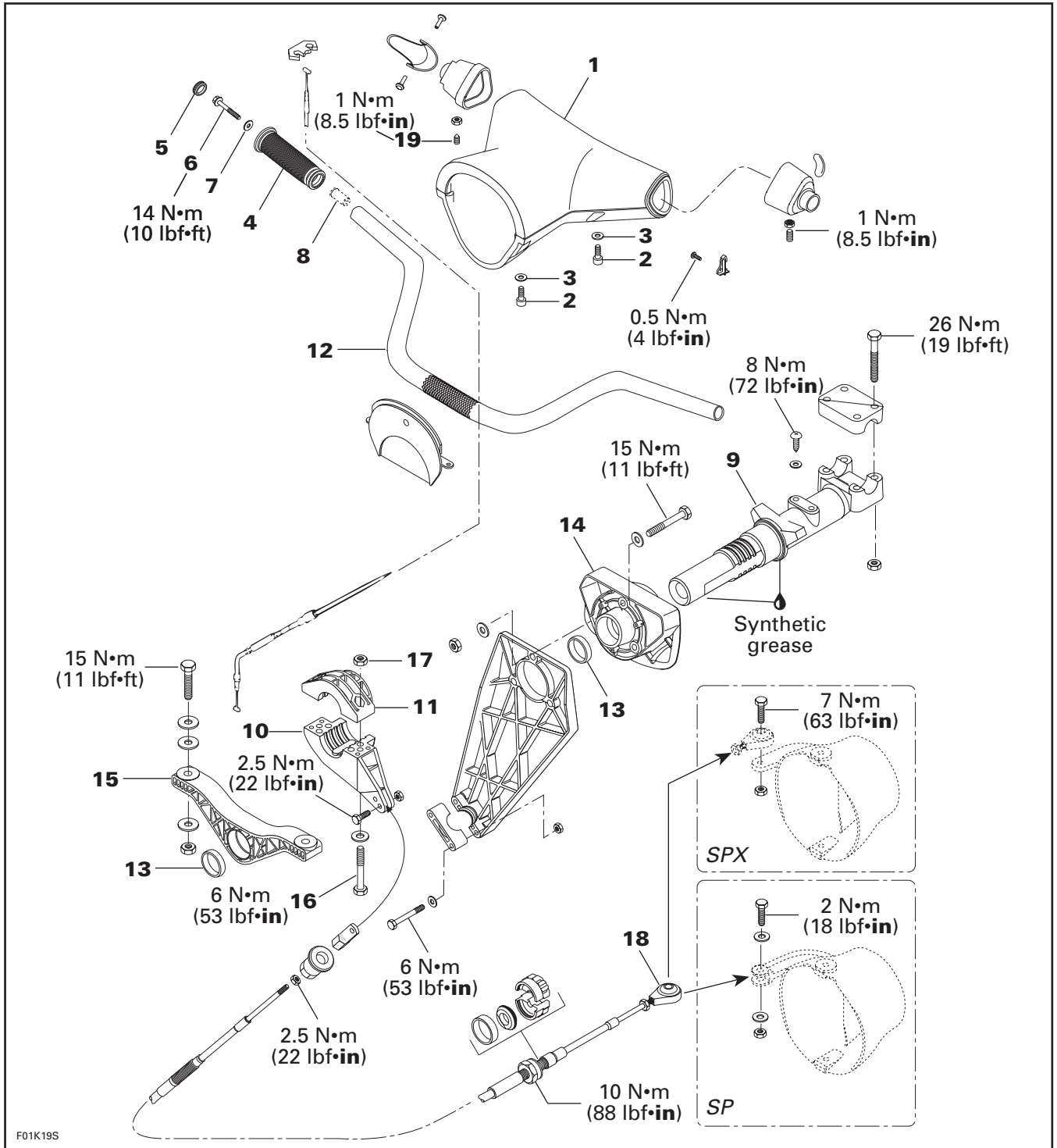

F01K19S

Section 09 STEERING SYSTEM

Sub-Section 02 (SP AND SPX MODELS)

REMOVAL AND INSTALLATION

1, Cover

To replace the cover, loosen set screws **no. 19** of handlebar housing.

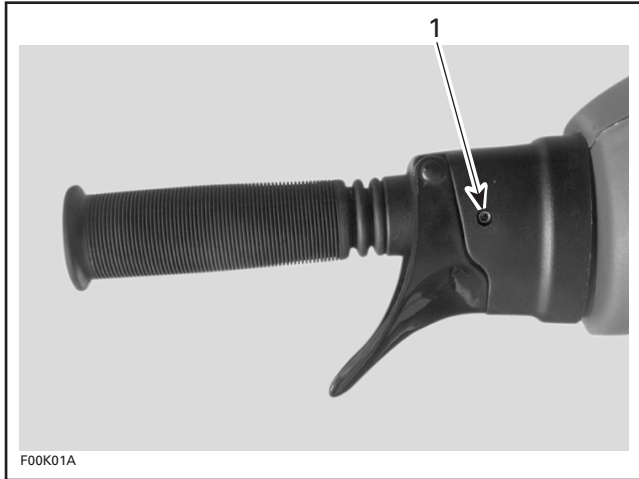

1. Set screw

Remove and reinstall 4 screws **no. 2** and washers **no. 3**.

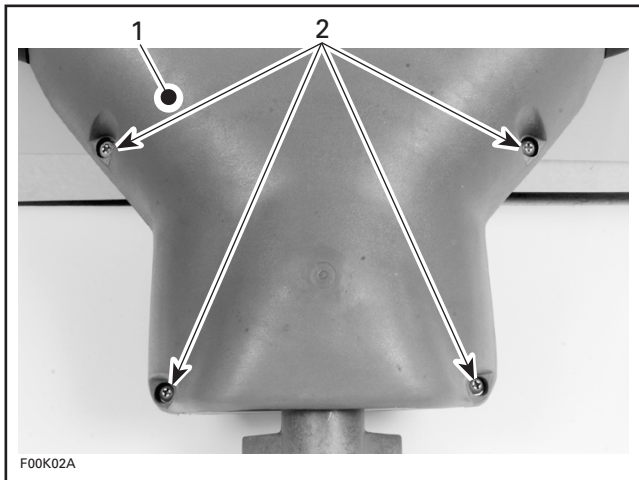

1. Cover
2. Screws

4,8, Grip and Grip Insert

To remove grip, just pull out cap **no. 5** from grip end and remove screw **no. 6** and washer **no. 7**.

Pull out grip.

To verify grip insert for damage, remove it from handlebar.

When installing the grip insert in the handlebar **no. 12**, ensure that its notch is properly inserted in the hole beneath the handlebar.

Install grip **no. 4** on handlebar **no. 12** matching it to the hex form on the grip insert.

Install flat washer **no. 7** and screw **no. 6**.

Torque screw to 14 N•m (10 lbf•ft).

Install cap **no. 5**.

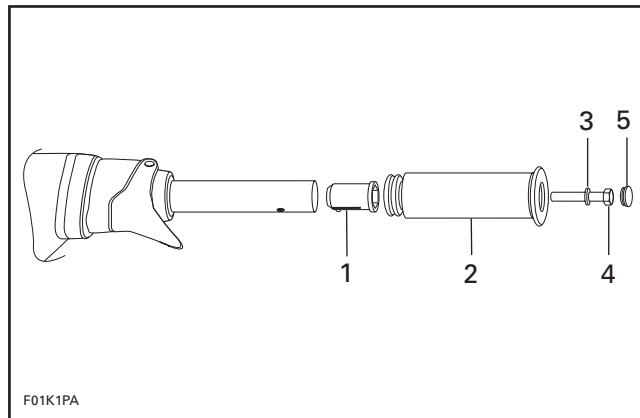

1. Grip insert
2. Grip
3. Flat washer
4. Screw. Torque to 14 N•m (10 lbf•ft)
5. Cap

▼ CAUTION

Ensure to install flat washer otherwise screw will damage grip end.

9,12, Steering Stem and Handlebar

REMOVAL

Disconnect wiring harnesses leading out of steering stem **no. 9**.

Disconnect throttle cable at carburetor.

Remove throttle cable from tie-blocks.

Unscrew bolts **no. 16** retaining support **no. 11** to steering stem arm **no. 10**.

Section 09 STEERING SYSTEM
Sub-Section 02 (SP AND SPX MODELS)

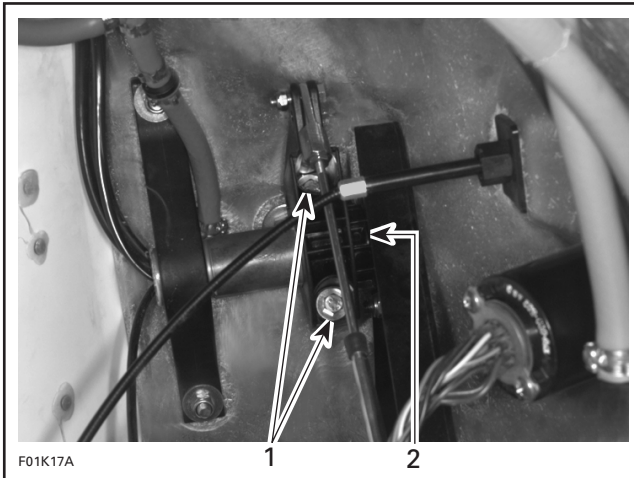

1. Bolts
2. Steering stem arm

Remove support no. 11 and steering stem arm no. 10 from steering stem.

NOTE: It is not necessary to remove steering cable from steering stem arm.

Pull out handlebar assembly.

▼ CAUTION

While performing this procedure, take precautions to avoid damaging throttle cable and wiring harnesses.

INSTALLATION

Installation is essentially the reverse of removal procedures. However, pay particular attention to the following.

13, Thrust Ring

Lubricate with synthetic grease thrust ring of rear support no. 14 and front support no. 15.

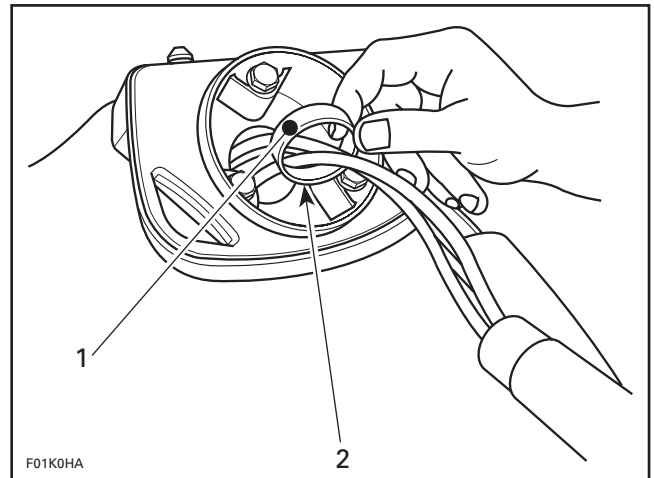

REAR SUPPORT

1. Apply synthetic grease
2. Thrust ring shown removed for more clarity

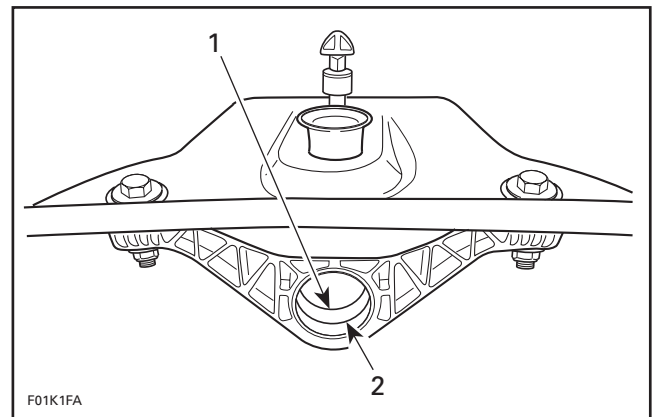

FRONT SUPPORT

1. Apply synthetic grease
2. Thrust ring

NOTE: Make sure thrust rings are properly installed.

10,11, Steering Stem Arm and Support

Install support to steering stem arm.

NOTE: Insert lock nuts no. 17 in support. Screw only a few threads of the bolts no. 16.

Section 09 STEERING SYSTEM

Sub-Section 02 (SP AND SPX MODELS)

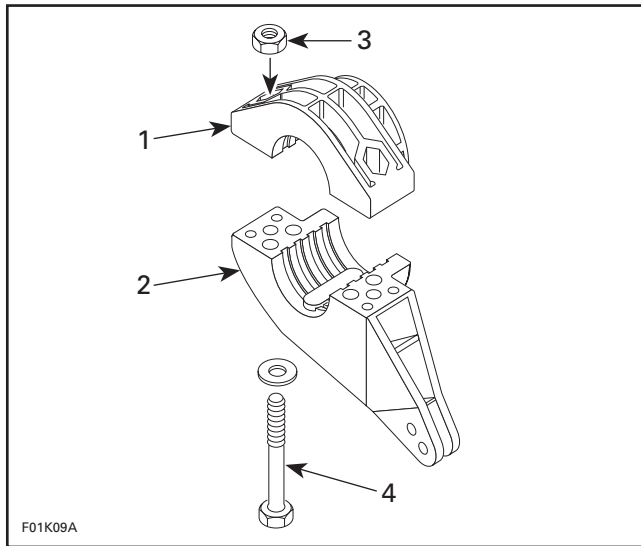

TYPICAL

1. Support
2. Steering stem arm
3. Insert lock nuts
4. Screw only a few threads of the bolts

9,12, Steering Stem and Handlebar

Install handlebar assembly into rear support **no. 14**, taking care at the same time to insert throttle cable and wiring harnesses.

From bilge, route throttle cable and wiring harnesses into support **no. 11** and steering stem arm **no. 10**, and finally in front steering support **no. 15**.

▼ CAUTION

While performing this procedure, take precautions to avoid damaging throttle cable and wiring harnesses.

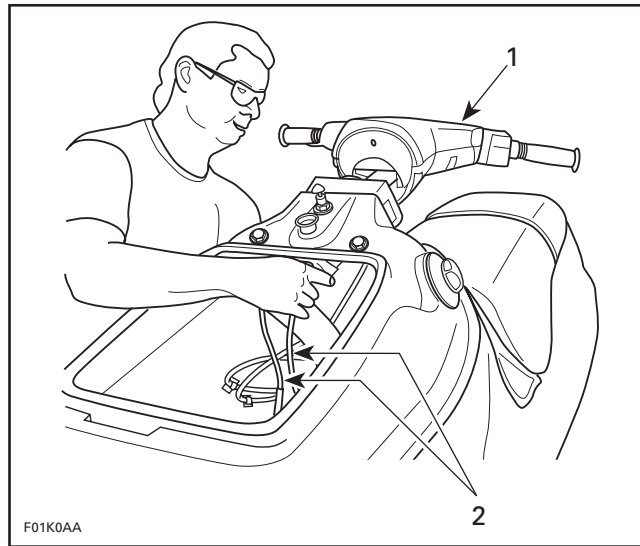

1. Install handlebar assembly
2. Route throttle cable and wiring harnesses at the same time

Push handlebar assembly until steering stem **no. 9** is well seated into steering supports **no. 14** and **no. 15**.

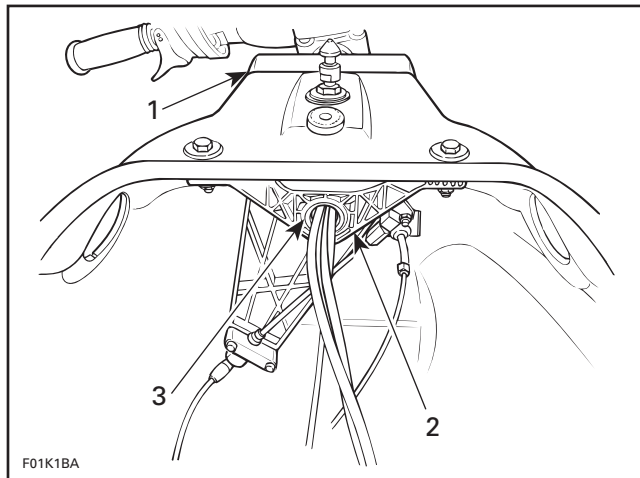

1. Rear support (steering collar)
2. Front support
3. Steering stem

Position steering stem arm **no. 10** and support **no. 11** onto steering stem.

◆ WARNING

Make sure integrated flat key of steering stem arm is properly seated in steering stem keyway. Steering stem arm must be locked in place before torquing the bolts.

Section 09 STEERING SYSTEM

Sub-Section 02 (SP AND SPX MODELS)

Torque bolts of steering stem arm no. 10 to 6 N•m (53 lbf•in).

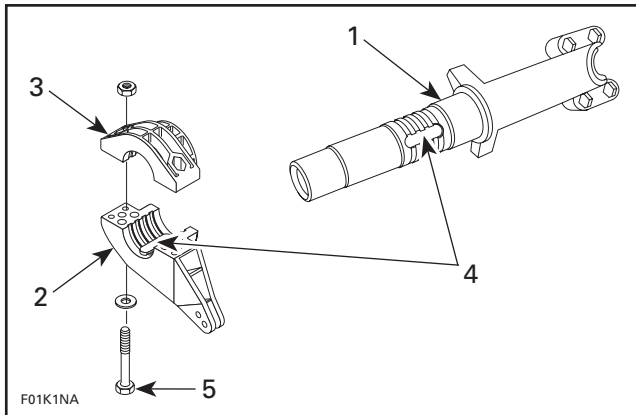

1. Steering stem
2. Steering stem arm
3. Support
4. Torque to 6 N•m (53 lbf•in)
5. Integrated flat key must be seated in keyway and steering stem arm locked in place

NOTE: Once steering stem arm is properly tightened, look between body and front support to make sure there is no gap between steering stem arm and its support. If there is a gap, components are not properly installed.

Connect wiring harnesses.

Route throttle cable alongside bilge. Insert cable barrel into carburetor throttle lever.

Insert throttle cable alongside choke cable in tie-blocks.

For throttle cable adjustment, refer to FUEL SYSTEM 05-04.

18, Ball Joint

Secure steering cable ball joint to nozzle as per following illustrations.

▼ CAUTION

Ensure the ball joint is parallel ($\pm 5^\circ$) to the nozzle arm.

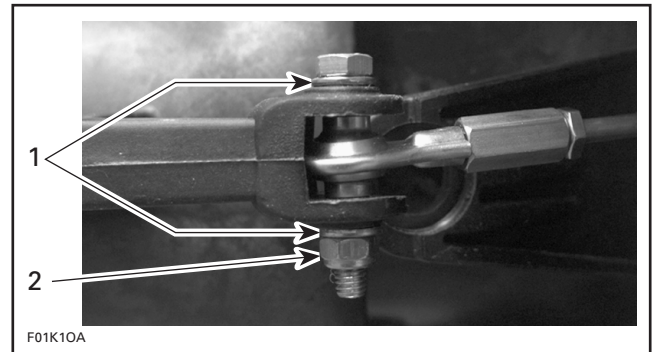

SP MODEL

1. One washer each side of arm
2. Torque nut to 2 N•m (18 lbf•in)

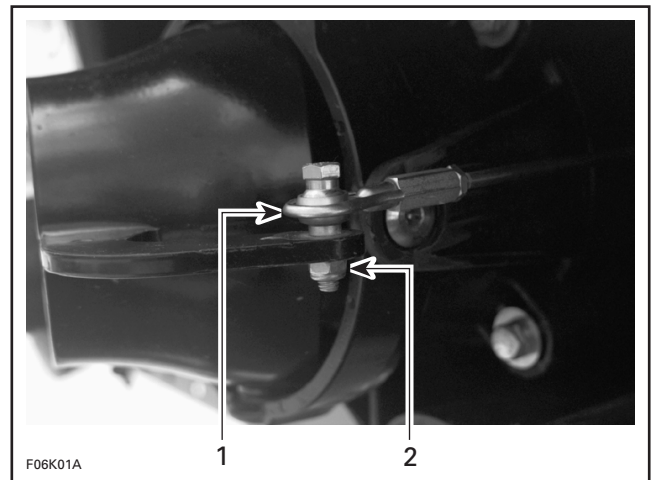

SPX MODEL

1. Ball joint on top of arm
2. Torque nut to 7 N•m (62 lbf•in)

STEERING ALIGNMENT

For steering alignment, refer to STEERING SYSTEM 09-06.

GTS MODEL

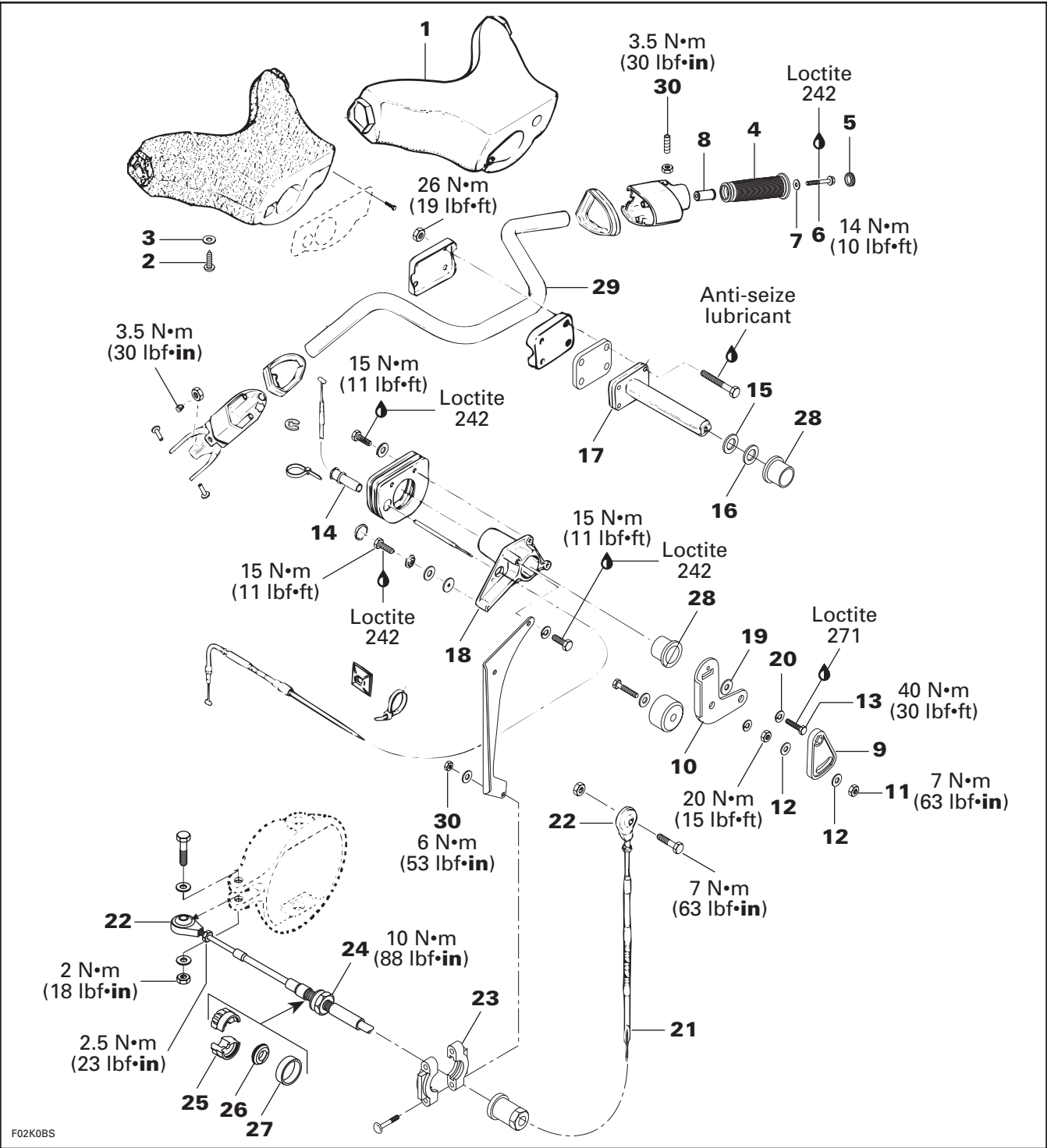

F02K0BS

Section 09 STEERING SYSTEM

Sub-Section 03 (GTS MODEL)

REMOVAL AND INSTALLATION

1, Cover

To replace the cover, loosen set screws **no. 30** of handlebar housing.

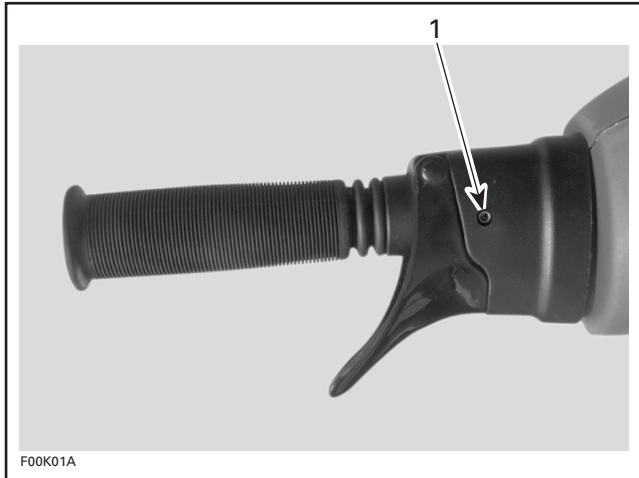

1. Set screw

Remove and reinstall 4 screws **no. 2** and washers **no. 3**.

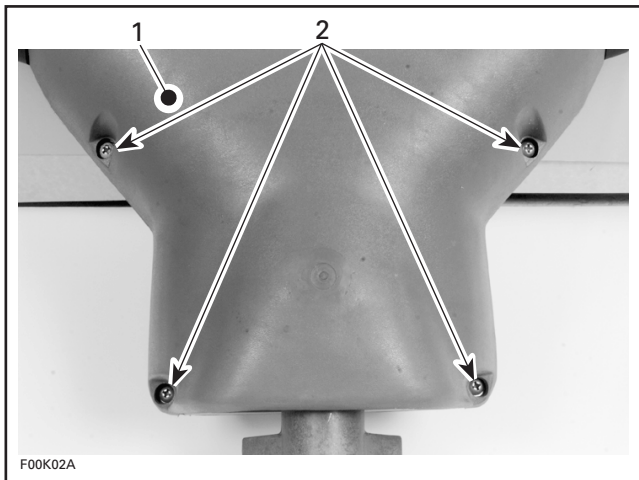

1. Cover
2. Screws

4,8, Grip and Grip Insert

To remove grip, just pull out cap **no. 5** from grip end and remove screw **no. 6** and washer **no. 7**.

Pull out grip.

To verify grip insert for damage, remove it from handlebar.

When installing the grip insert in handlebar **no. 29**, ensure that its notch is properly inserted in the hole beneath the handlebar.

Install grip **no. 4** on handlebar **no. 29** matching it to the hex form on the grip insert.

Install flat washer **no. 7** and screw **no. 6**.

Torque screw to 14 N•m (10 lbf•ft).

Install cap **no. 5**.

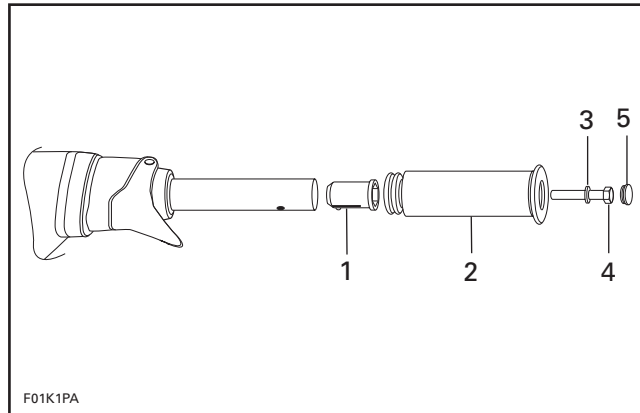

1. Grip insert
2. Grip
3. Flat washer
4. Screw. Torque to 14 N•m (10 lbf•ft)
5. Cap

▼ CAUTION

Ensure to install flat washer otherwise screw will damage grip end.

17,29, Steering Stem and Handlebar

REMOVAL

Disconnect wiring harnesses leading out of dashboard hole.

Disconnect throttle cable at carburetor.

Remove throttle cable from tie-block and clip.

Unscrew nut **no. 11** retaining locking plate **no. 9**; then remove locking plate and washers **no. 12**.

Unscrew screw **no. 13** of steering stem arm **no. 10**.

Pull out handlebar and steering stem.

NOTE: It is not necessary to disconnect steering cable to remove handlebar and steering stem.

28, Bushing

Inspect bushings for wear, cracks, scoring, etc. Replace as necessary.

INSTALLATION

14, Grommet

Insert throttle cable through dashboard hole and slide grommet on cable.

Insert grommet in dashboard hole and pull it from inside bilge.

NOTE: To ease installation, apply water on grommet.

Insert wires of monitoring beeper and start/stop button.

17,29, Steering Stem and Handlebar

Insert spring washer no. 15 and the shim no. 16 onto steering stem.

Insert steering stem into support no. 18.

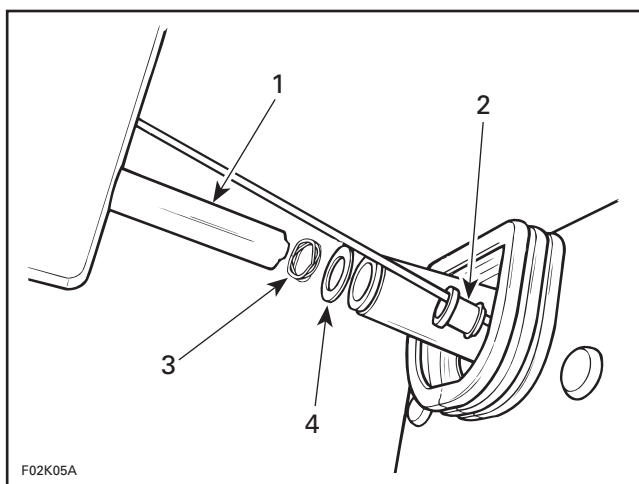

- 1. Steering stem
- 2. Grommet
- 3. Spring washer
- 4. Shim

Properly position steering stem arm no. 10 on steering stem. Make sure to insert stem tenon into arm mortise.

Apply Loctite 271 (red) on threads of screw no. 13.

Install large flat washer no. 19, lock washer no. 20 and screw no. 13. Torque screw to 40 N•m (30 lbf•ft).

▼ CAUTION

Always install large flat washer with the X stamped side facing the lock washer.

◆ WARNING

The recommended torque and Loctite must be applied on screw. Steering arm mortise must seat properly on steering stem tenon.

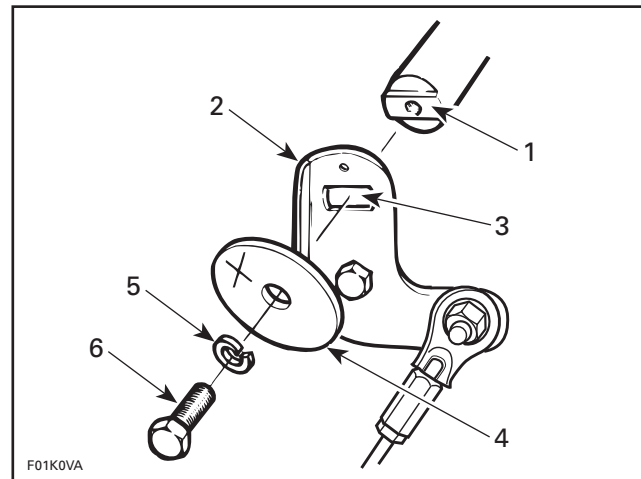

TYPICAL

- 1. Steering stem tenon
- 2. Steering stem arm
- 3. Mortise
- 4. Large flat washer with X
- 5. Lock washer
- 6. Screw, apply Loctite 271 and torque to 40 N•m (30 lbf•ft)

Position 8 mm flat washer no. 12 on steering stopper screw then install locking plate no. 9 over steering stem head screw.

NOTE: Ensure locking plate slot is inserted in steering stopper screw.

Install a second 8 mm flat washer no. 12 and secure locking plate using jam nut no. 11. Torque nut to 7 N•m (62 lbf•in).

Section 09 STEERING SYSTEM

Sub-Section 03 (GTS MODEL)

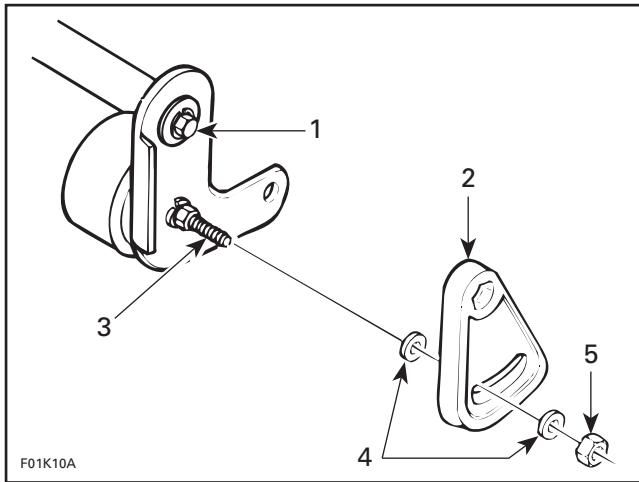

STEERING CABLE NOT SHOWN FOR MORE CLARITY

1. Steering stem head screw
2. Locking plate
3. Steering stopper screw
4. 8 mm flat washers
5. Torque nut to 7 N•m (62 lbf•in)

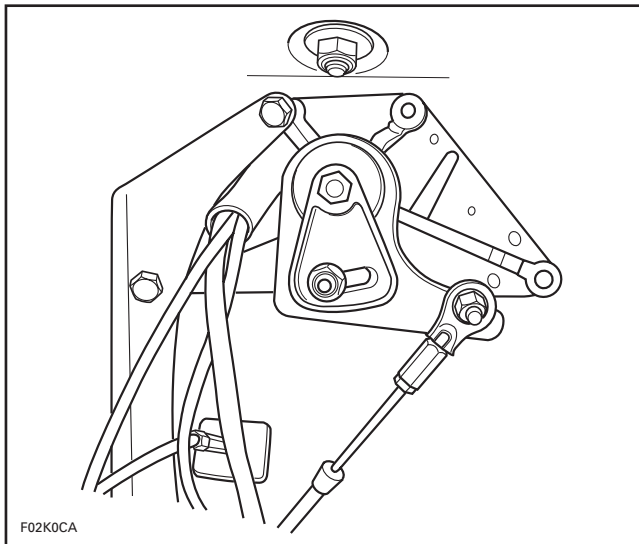

TYPICAL

21, Steering Cable

To replace steering cable, proceed as follows:

Disconnect ball joint no. 22 at steering stem arm no. 19.

Loosen nuts no. 30 and open retaining block no. 23.

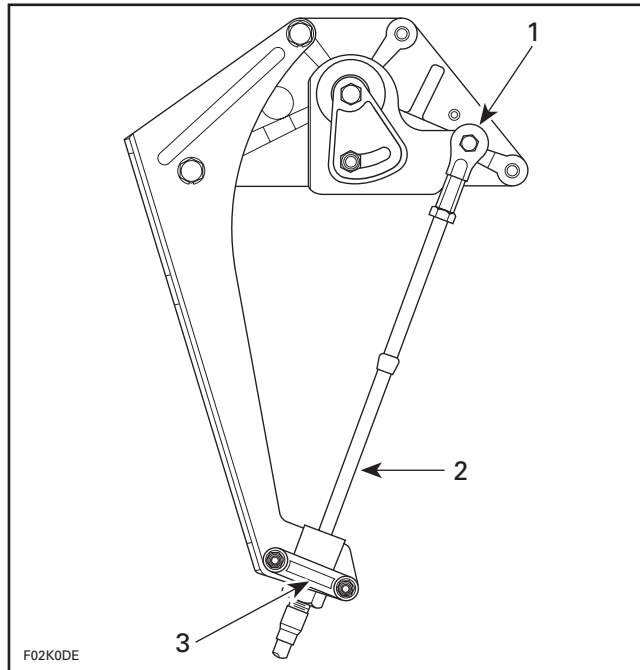

TYPICAL

1. Ball joint
2. Steering cable
3. Retaining block

Disconnect ball joint no. 22 at jet pump nozzle; then, remove ball joint.

From bilge, unscrew nut no. 24 retaining steering cable to hull.

Remove half rings no. 25, rubber washer no. 26 and retaining ring no. 27.

NOTE: Move shift lever in reverse position to lower reverse gate. It will ease parts removal.

Remove steering cable from tie-block and clips.

Pull out steering cable.

Assembly is essentially the reverse of disassembly procedures. However pay particular attention to the following.

22, Ball Joint

Inspect and reuse ball joints only if they are in good condition.

Secure steering cable ball joint to nozzle as per following illustration.

▼ CAUTION

Ensure the ball joint is parallel ($\pm 5^\circ$) to the nozzle arm.

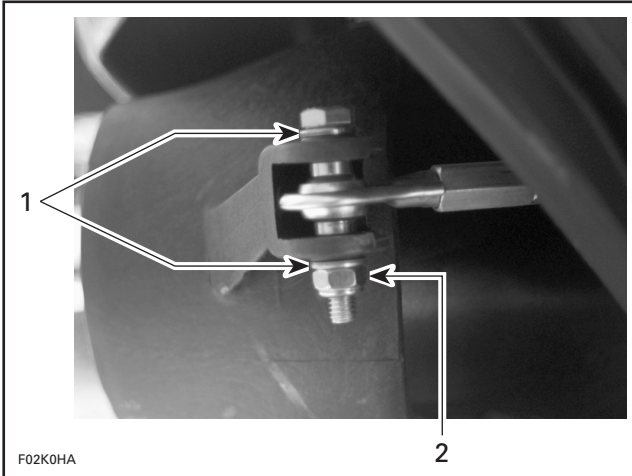

1. One washer each side of arm
2. Torque nut to 2 N•m (18 lb•in)

STEERING ALIGNMENT

For steering alignment procedure, refer to STEERING SYSTEM 09-06.

GS, GSI, GSX, GTI AND GTX MODELS

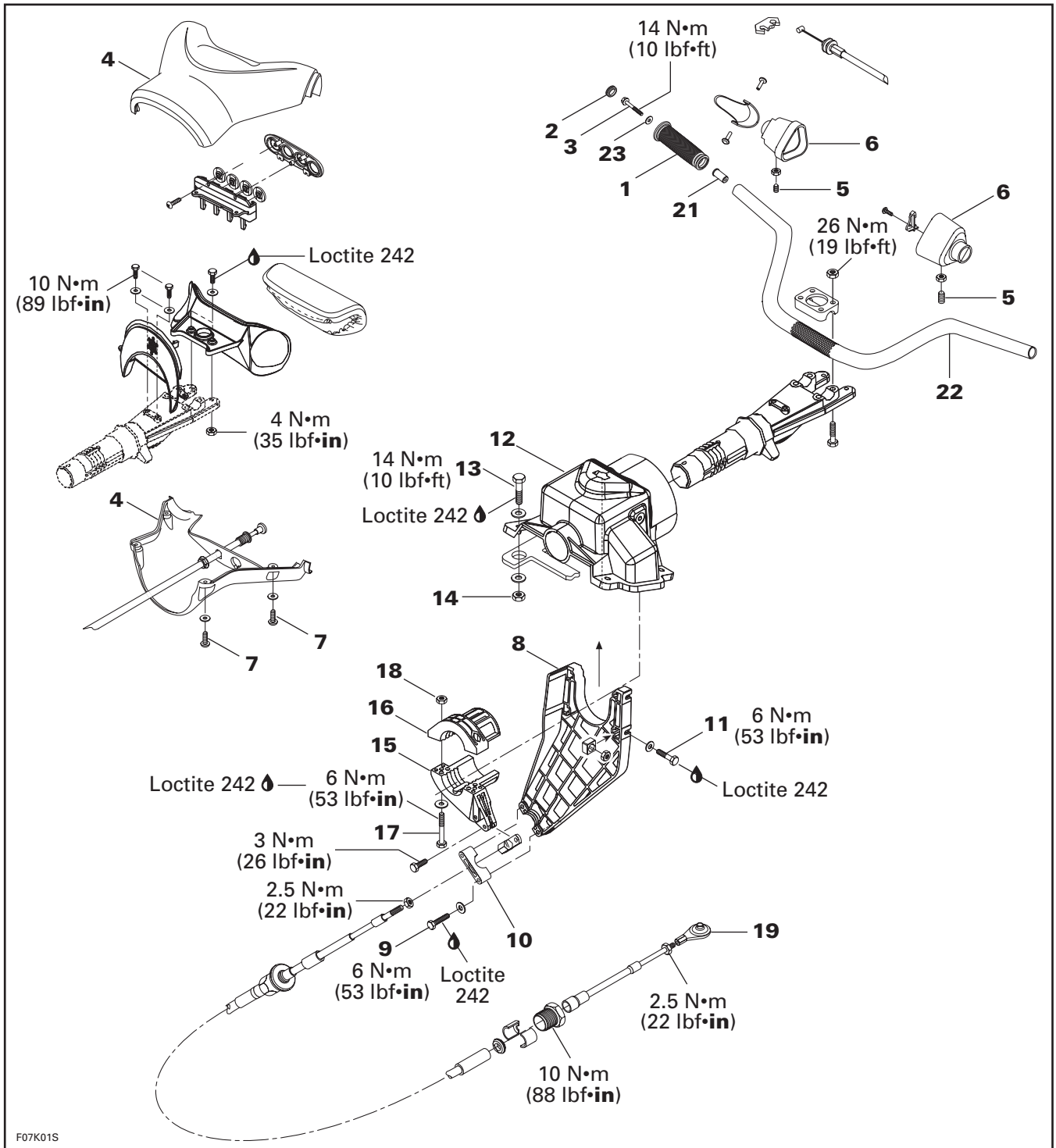

Section 09 STEERING SYSTEM

Sub-Section 04 (GS, GSI, GSX, GTI AND GTX MODELS)

DISASSEMBLY

1,21, Grip and Grip Insert

To remove grip, pull out cap no. 2 and remove screw no. 3.

Pull out grip.

To verify grip insert for damage, remove it from handlebar no. 22.

4, Cover

Remove grips no. 1.

Loosen set screws no. 5 of handlebar housings no. 6.

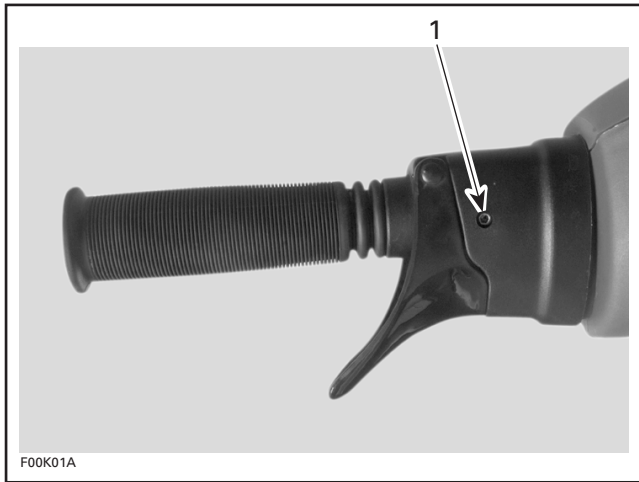

1. Set screw

Remove 4 screws no. 7.

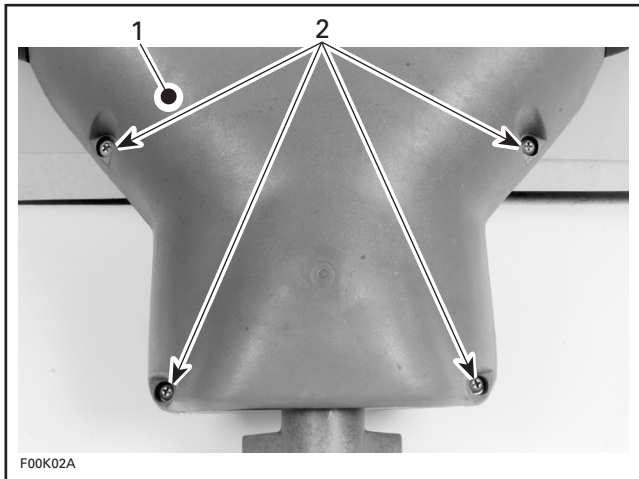

TYPICAL

1. Cover
2. Screws

Remove cover.

8, Cable Support

Loosen bolts no. 9 and remove retaining block no. 10.

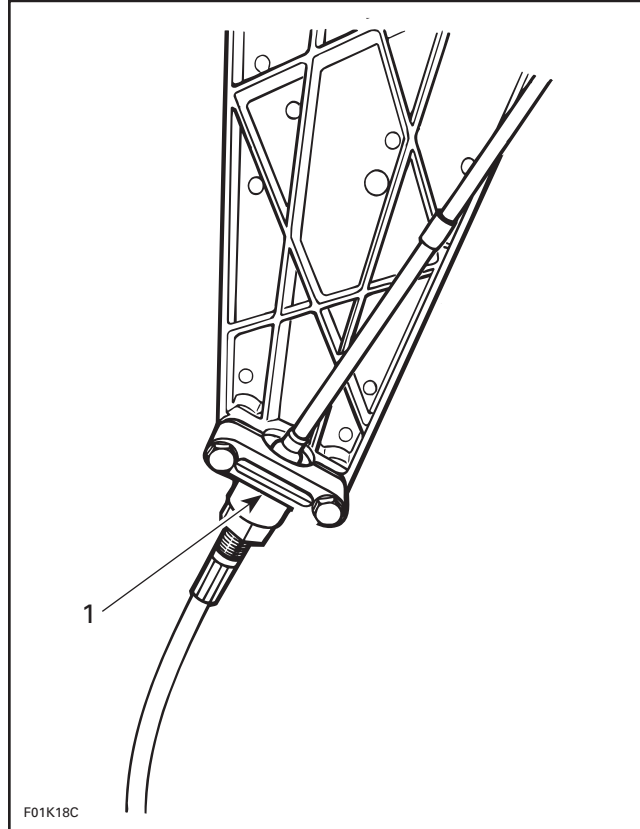

1. Retaining block

Loosen bolts no. 11 each side of steering support no. 12.

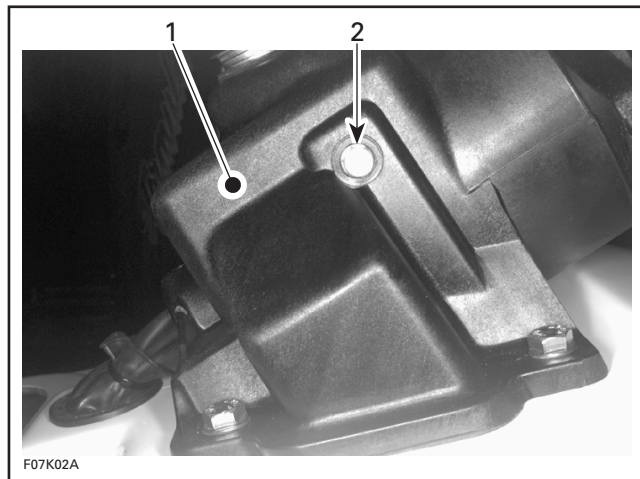

1. Steering support
2. Bolt

Section 09 STEERING SYSTEM

Sub-Section 04 (GS, GSI, GSX, GTI AND GTX MODELS)

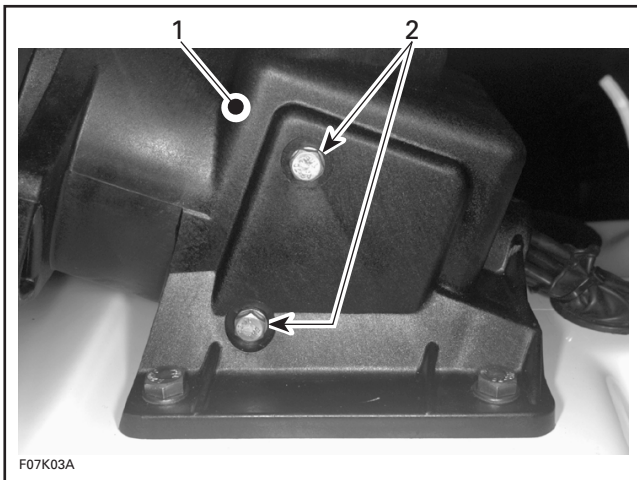

1. Steering support
2. Bolts

Remove support.

12, Steering Support

Cut tie rap securing wiring harness boot.

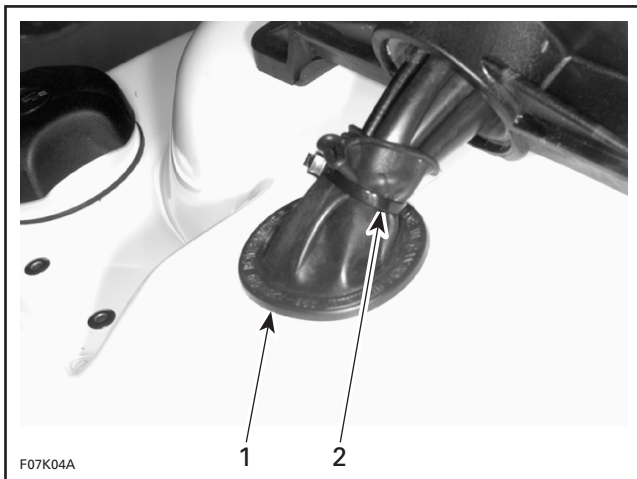

1. Boot
2. Tie rap

Disconnect the throttle and choke cables from carburetor levers.

Disconnect the wiring harnesses leading out of steering stem and cut tie rap.

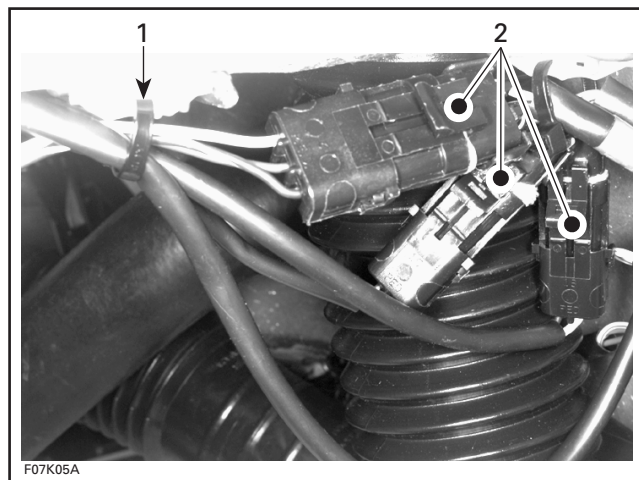

TYPICAL

1. Tie rap
2. Connectors

Disconnect the steering cable from the steering stem arm no. 15.

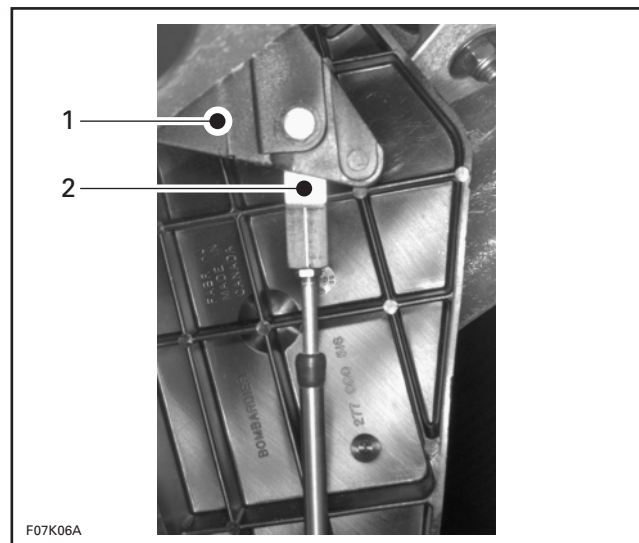

1. Steering stem arm
2. Steering cable

Loosen bolts no. 11 retaining cable support to steering support (refer to cable support no. 8).

Loosen bolts no. 13 and lock nuts no. 14.

Section 09 STEERING SYSTEM

Sub-Section 04 (GS, GSI, GSX, GTI AND GTX MODELS)

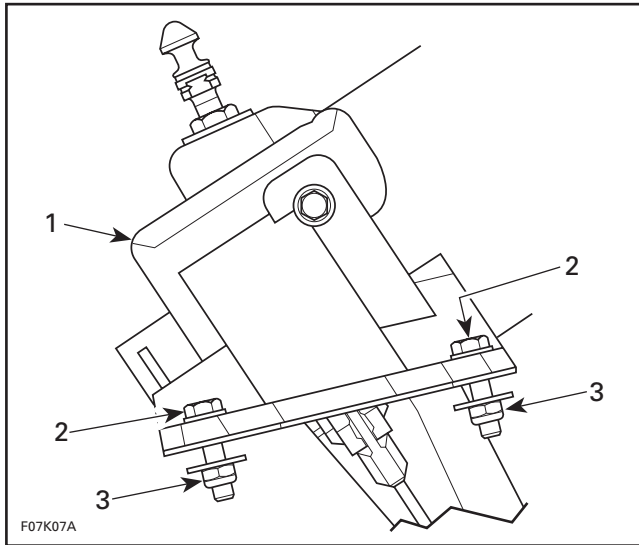

1. Steering support
2. Bolt
3. Lock nut

Remove steering support with handlebar, wiring harnesses and cables.

15,16, Steering Stem Arm and Support

Loosen bolts no. 17 retaining steering stem arm to support.

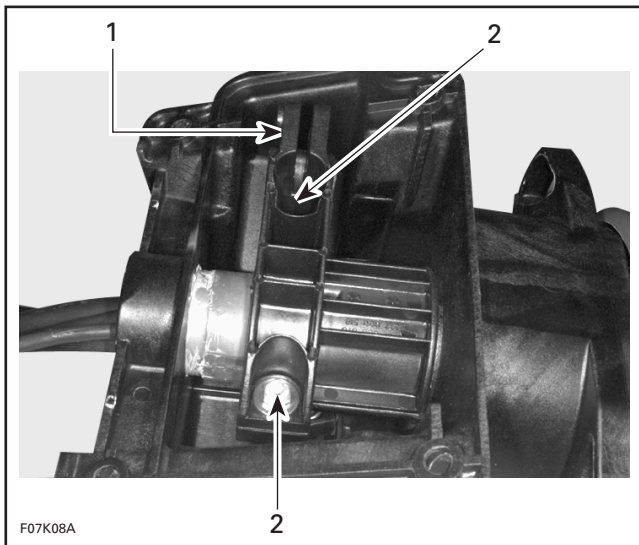

1. Steering stem arm
2. Bolt

Remove steering stem arm and support.

ASSEMBLY

Assembly is essentially the reverse of disassembly procedures. However, pay particular attention to the following.

▼ CAUTION

Apply all specified torques and service products as per main illustration at the beginning of this sub-section.

1,21, Grip and Grip Insert

When installing the grip insert no. 21 in the handlebar no. 22, ensure that its notch is properly inserted in the hole beneath the handlebar.

Install grip no. 1 on handlebar no. 22 matching it to the hex form on the grip insert.

Install flat washer no. 23 and screw no. 3.

Torque screw to 14 N•m (10 lbf•ft).

Install cap no. 2.

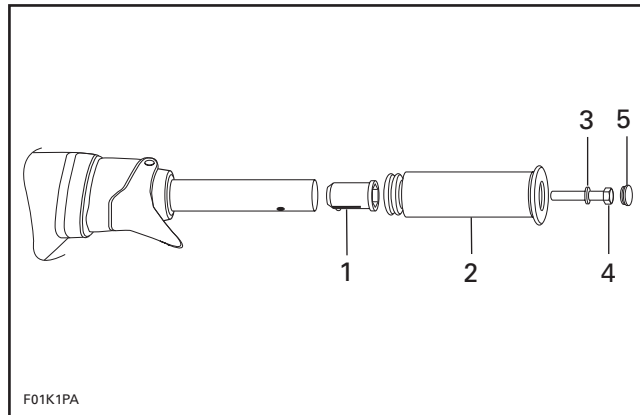

1. Grip insert
2. Grip
3. Flat washer
4. Screw. Torque to 14 N•m (10 lbf•ft)
5. Cap

▼ CAUTION

Ensure to install flat washer otherwise screw will damage grip end.

15,16, Steering Stem Arm and Support

Position steering stem arm and support onto steering stem.

◆ WARNING

Make sure the integrated flat keys of the steering stem arm and support are properly seated in steering stem keyways. Steering stem arm must be locked in place before torquing the bolts.

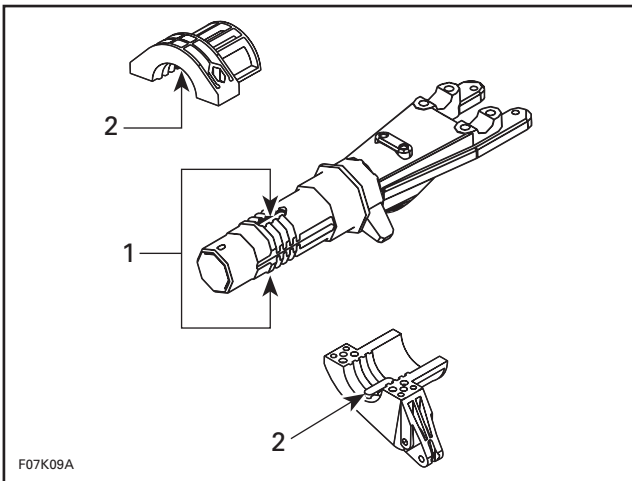

- 1. Keyways
- 2. Integrated flat key

Replace lock nuts **no. 18** by new ones.

Torque bolts **no. 17** of steering stem arm to **6 N•m (53 lbf•in)**.

19, Ball joint

Secure the steering cable ball joint **no. 19** to the nozzle as per following illustrations.

▼ CAUTION

Ensure the ball joint is parallel ($\pm 5^\circ$) to the nozzle arm.

GSI and GSX Models

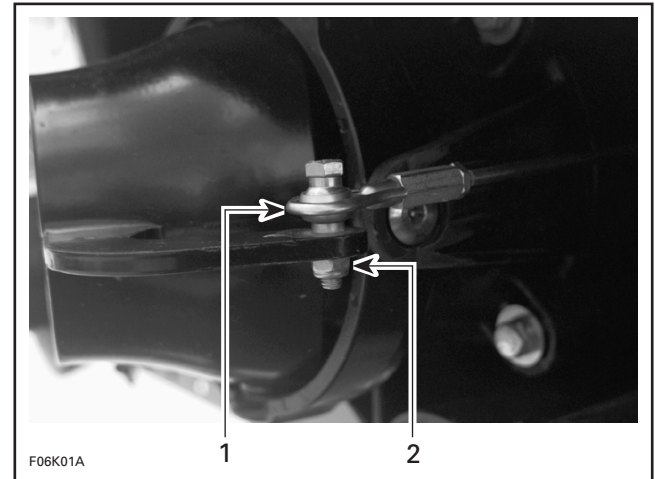

- 1. Ball joint on top of steering arm
- 2. Torque nut to **7 N•m (62 lbf•in)**

GS, GTI, and GTX Models

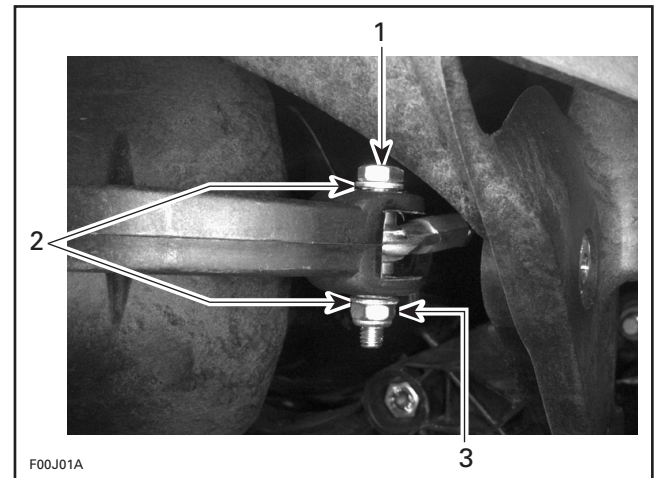

TYPICAL

- 1. Bolt
- 2. Flat washers
- 3. Lock nut. Torque to **2 N•m (18 lbf•in)**

STEERING ALIGNMENT

For steering alignment procedure, refer to STEERING SYSTEM 09-06.

HX AND XP MODELS

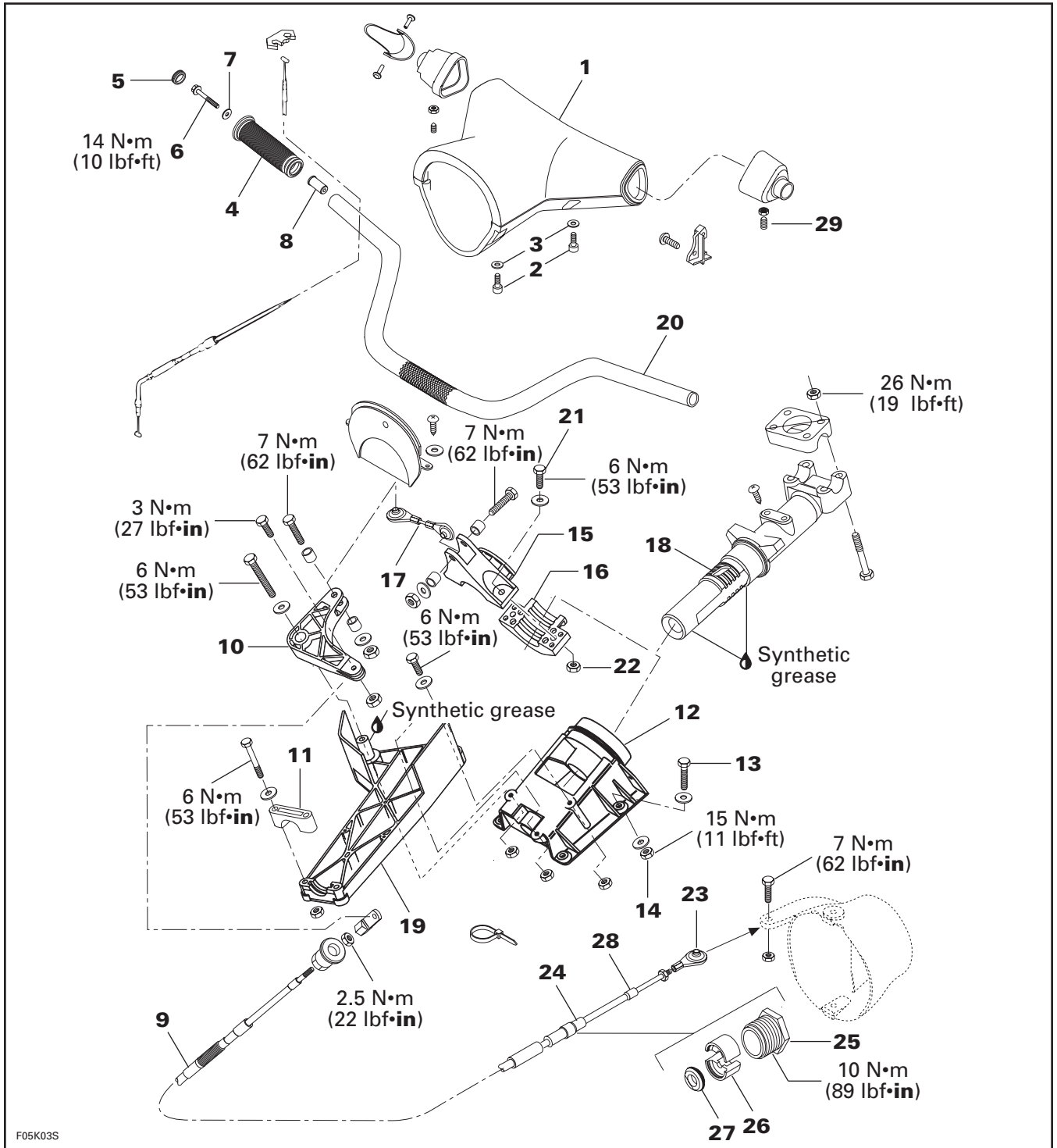

F05K03S

Section 09 STEERING SYSTEM

Sub-Section 05 (HX AND XP MODELS)

REMOVAL

1, Cover

To remove the cover, loosen set screws **no. 29** of handlebar housing.

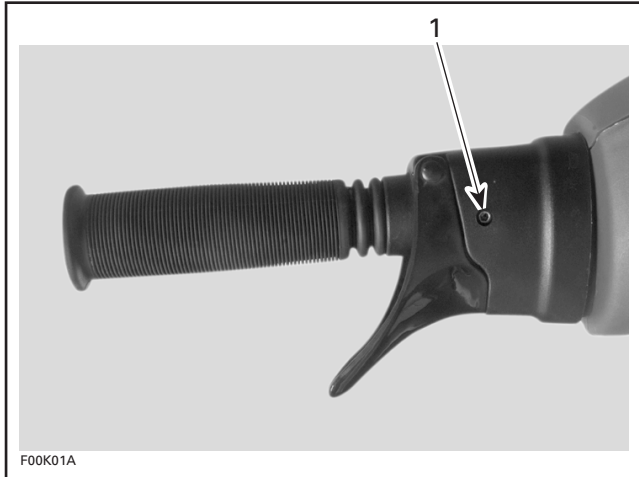

1. Set screws

Remove 4 screws **no. 2** and washers **no. 3**.

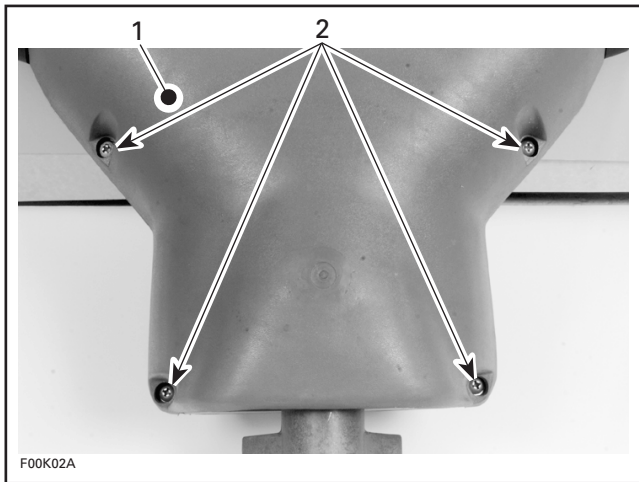

TYPICAL

1. Cover
2. Screws

4, Grip

To remove grip, pull out cap **no. 5** from grip end and remove screw **no. 6** and washer **no. 7**.

Pull out grip.

8, Grip Insert

To verify grip insert for damage, remove it from handlebar.

18,20, Steering Stem and Handlebar

Remove the hood cover by loosening the 4 plastic Phillips screws. They may need to be replaced after one use.

Disconnect steering cable **no. 9** from lever **no. 10** of steering stem arm.

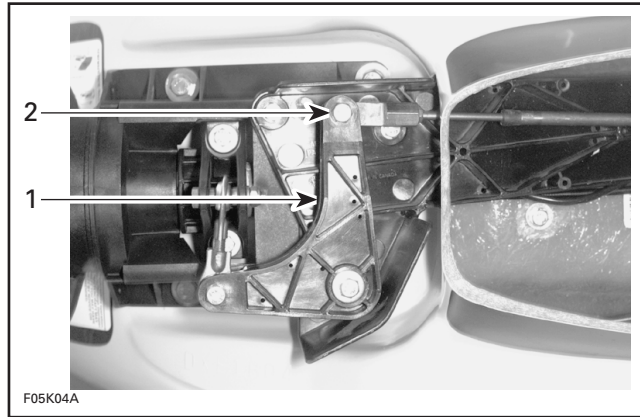

1. Lever
2. Disconnect cable

Remove retaining block **no. 11** of cable support.

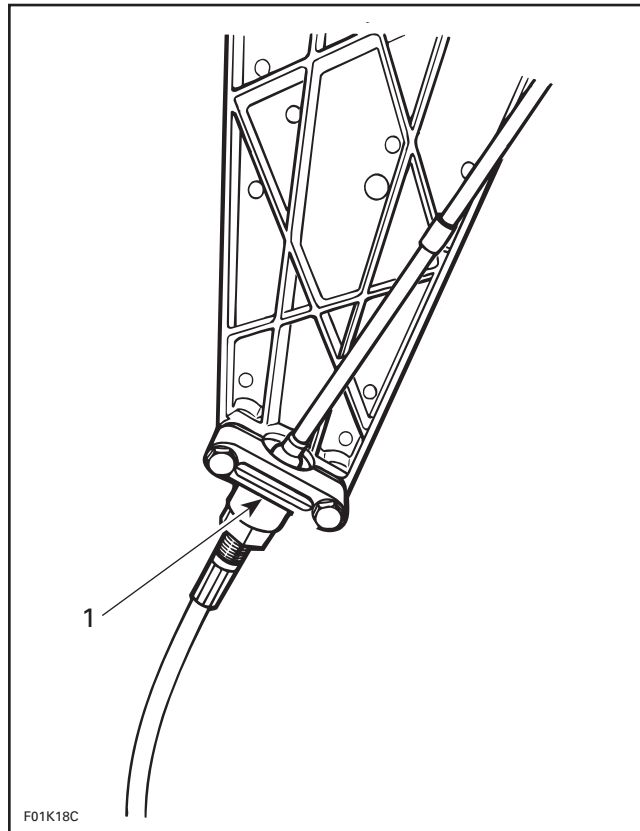

1. Retaining block

Disconnect wires of monitoring beeper and start/stop switch.

Section 09 STEERING SYSTEM

Sub-Section 05 (HX AND XP MODELS)

Open hood.

Disconnect throttle cable from carburetor linkage.

Pull out boot from hood and remove throttle cable from boot.

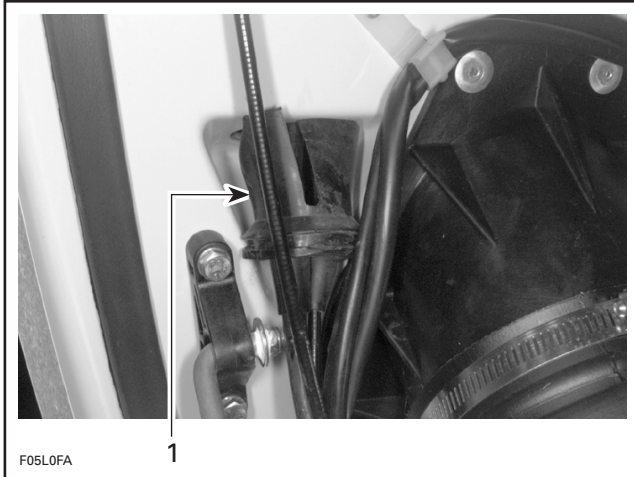

1. Boot

Loosen bolts no. 13 and nuts no. 14 of steering support no. 12.

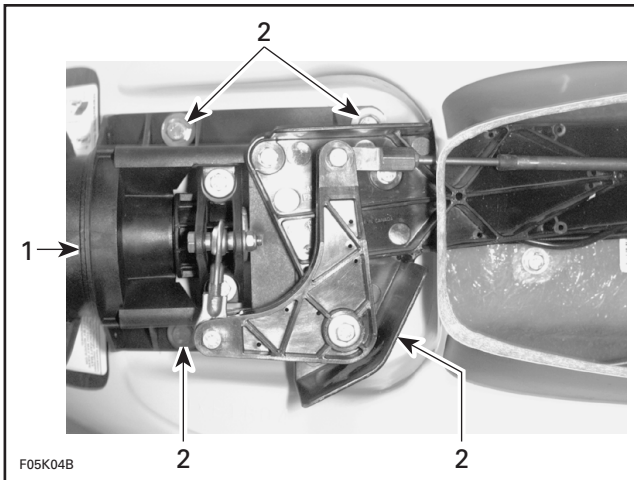

1. Steering support
2. Bolts

Remove steering system assembly.

9, Steering Cable

Disconnect steering cable from steering stem arm lever no. 10.

Remove retaining block no. 11 of cable support no. 19.

Pull out boot of steering cable and throttle cable from hood.

Disconnect ball joint no. 23 of steering cable no. 9 from jet pump nozzle.

Remove ball joint no. 23, boots no. 24 and no. 28, nut no. 25, half rings no. 26 and O-ring no. 27 from steering cable.

Remove steering cable from watercraft.

DISASSEMBLY

Disconnect link rod no. 17 from steering stem arm no. 15 and lever no. 10.

Slide the steering stem arm no. 15 and support no. 16 rearward and rotate them 90°.

Remove the 2 M6 × 25 screws no. 21 and nuts no. 22.

Remove the steering stem arm no. 15.

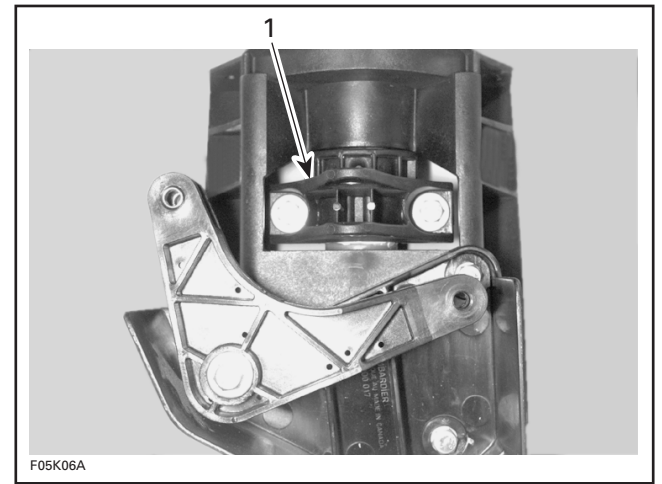

1. Steering stem arm

Pull out steering stem no. 18 from steering support no. 12.

Remove lever no. 10 from cable support no. 19.

ASSEMBLY AND INSTALLATION

Assembly and installation are essentially the reverse of removal and disassembly procedures. However, pay particular attention to the following.

10, Lever

Prior installing lever, apply synthetic grease to pivot.

18, Steering Stem

Apply synthetic grease to front and rear thrust bearing surface.

Section 09 STEERING SYSTEM

Sub-Section 05 (HX AND XP MODELS)

15,16, Steering Stem Arm and Support

Position steering stem arm and support onto steering stem arm no. 18.

◆ WARNING

Make sure integrated flat keys of steering stem arm and support are properly seated in steering stem keyways.

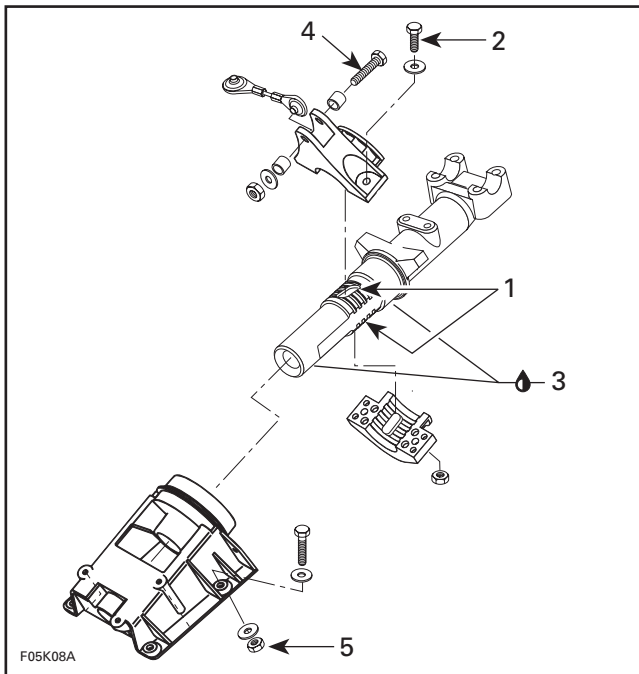

1. Keyways
2. Torque to 6 N•m (53 lbf•in)
3. Synthetic grease
4. Torque to 7 N•m (62 lbf•in)
5. Torque to 15 N•m (11 lbf•ft)

◆ WARNING

Correct torque must be strictly followed.

4,8, Grip and Grip Insert

When installing the grip insert in the handlebar no. 20, ensure that its notch is properly inserted in the hole beneath the handlebar.

Install grip no. 4 on handlebar no. 20 matching it to the hex form on the grip insert no. 8.

Install flat washer no. 7 and screw no. 6.

Torque screw to 14 N•m (10 lbf•ft).

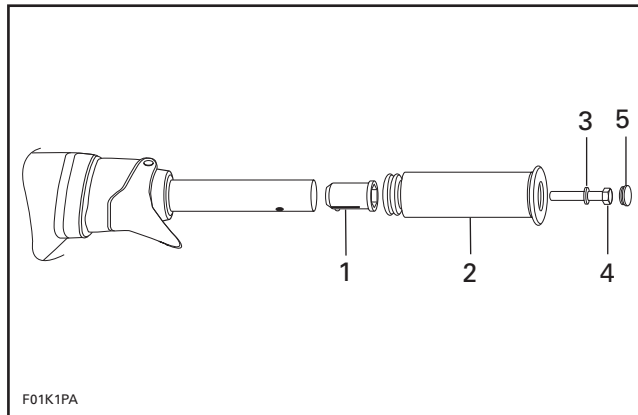

1. Grip insert
2. Grip
3. Flat washer
4. Screw. Torque screw to 14 N•m (10 lbf•ft)
5. Cap

▼ CAUTION

Ensure to install flat washer otherwise screw will damage grip end.

23, Ball Joint

Secure the steering cable ball joint no. 23 to the nozzle as per following illustration.

▼ CAUTION

Ensure the ball joint is parallel ($\pm 5^\circ$) to the nozzle arm.

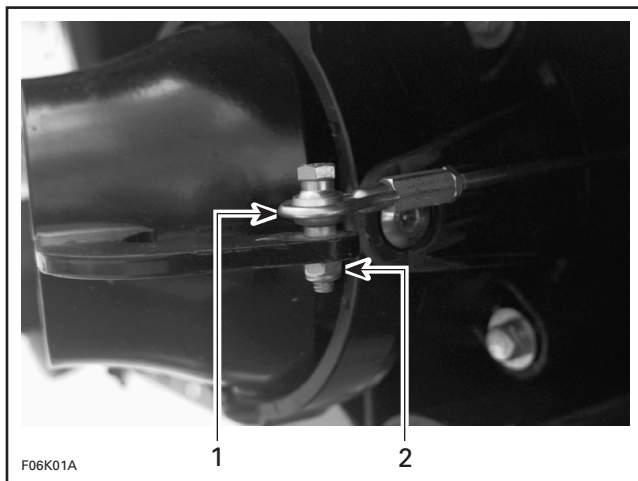

TYPICAL

1. Ball joint on top of steering arm
2. Torque nut to 7 N•m (62 lbf•in)

STEERING ALIGNMENT

For steering alignment procedure, refer to STEERING SYSTEM 09-06.

ALIGNMENT

GS, GSI, GSX, GTI and GTX Models

To position handlebar in straight ahead position, insert a pin in the steering support and turn the handlebar until the pin locks the steering stem.

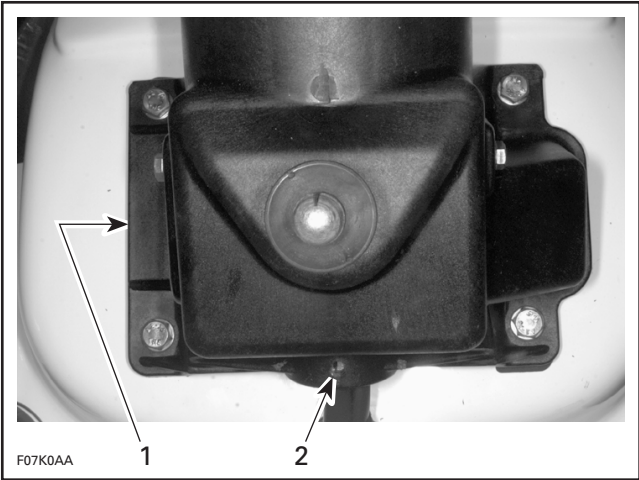

- 1. Steering support
- 2. Hole

SP, SPX, XP, HX and GTS Models

Position handlebar in straight ahead position by measuring each side the distance from handlebar grip end to floorboard.

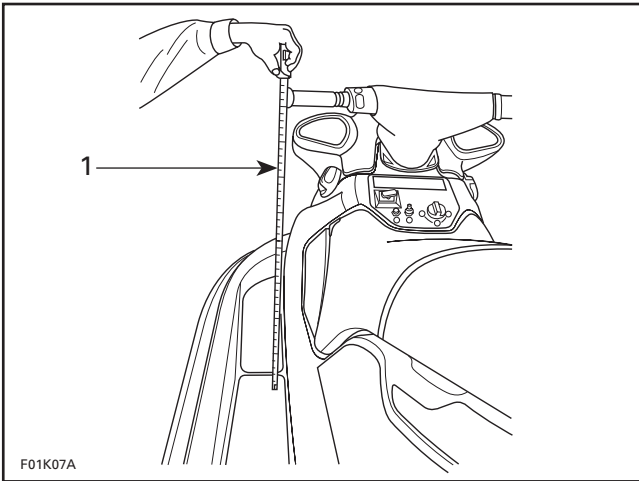

- 1. Measuring handlebar grip end/floorboard distance

Check jet pump nozzle position by placing a straight edge on nozzle outer end. Measure the distance on each side of the straight edge. It must be equalled.

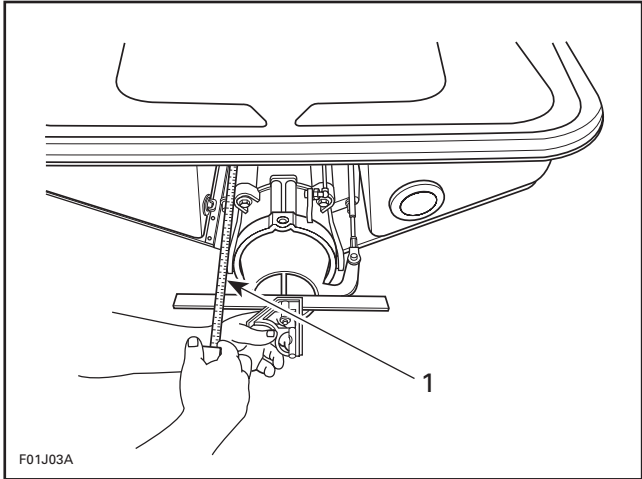

- TYPICAL
- 1. Measure the distance on each side of the straight edge

If necessary, steering alignment adjustment should be performed at steering cable support near steering stem.

Loosen retaining block at cable support.
Turn adjustment nut as required.

Section 09 STEERING SYSTEM

Sub-Section 06 (ALIGNMENT)

All Models Except GTS

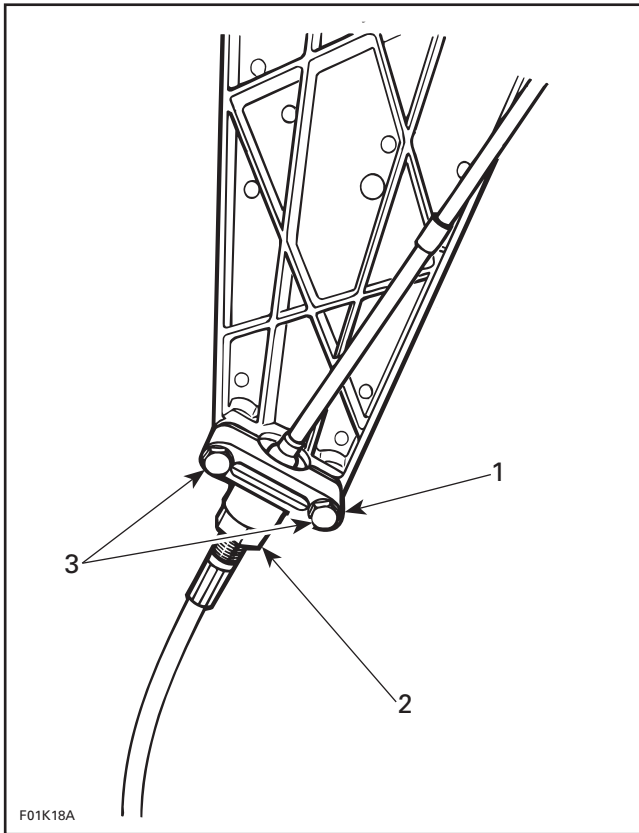

1. Retaining block
2. Adjustment nut
3. Bolts

GTS Model

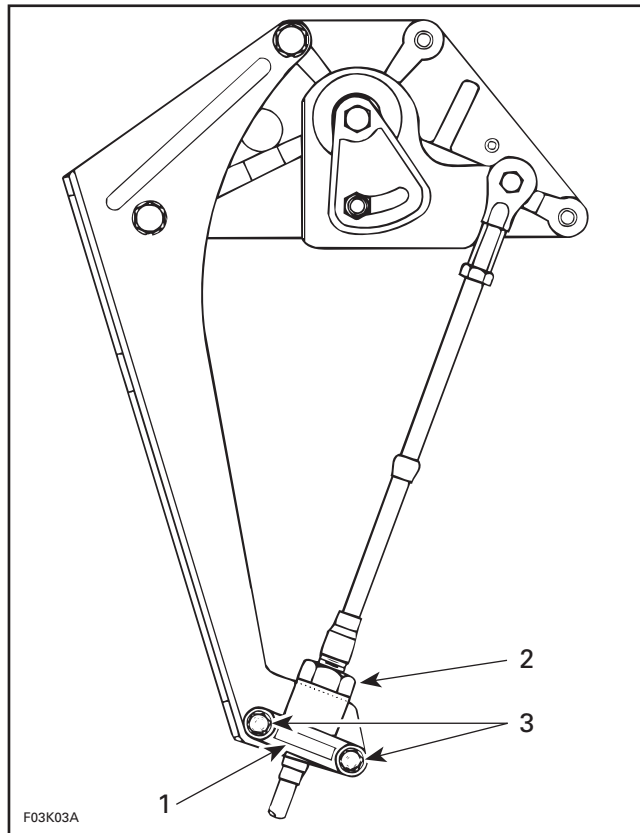

1. Retaining block
2. Adjustment nut
3. Bolts

All Models

After adjustment, torque retaining block bolts to 6 N•m (53 lbf•in).

▼ CAUTION

Verify when the handlebar is turned completely to the left or right side, that there is no interference with venturi housing.

TABLE OF CONTENTS

DIRECT ACTION SUSPENSION.....	10-02-1
DISASSEMBLY.....	10-02-2
INSPECTION	10-02-3
ASSEMBLY.....	10-02-3

DIRECT ACTION SUSPENSION

XP and HX Models

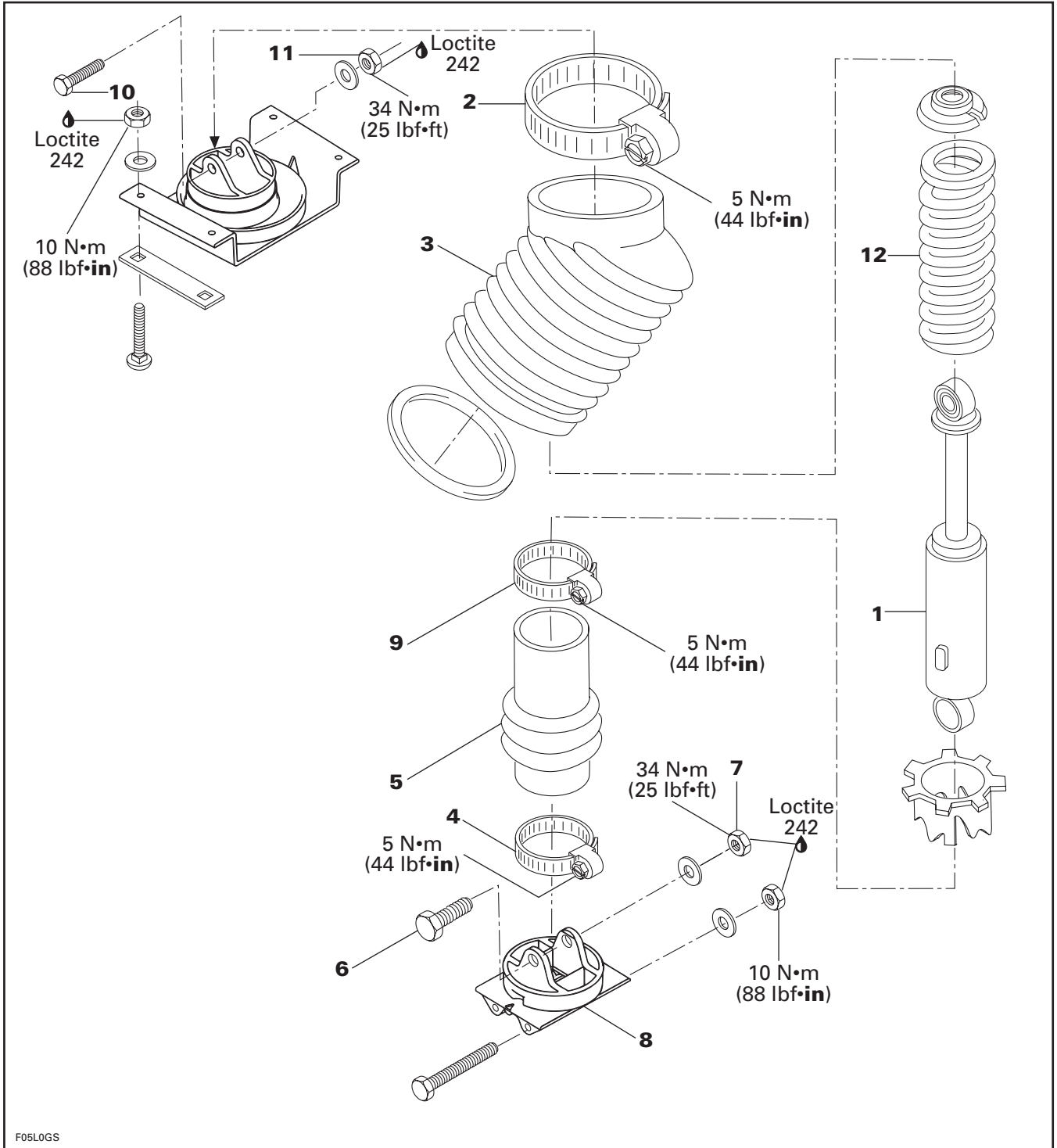

F05LOGS

Section 10 SUSPENSION

Sub-Section 02 (DIRECT ACTION SUSPENSION)

DISASSEMBLY

1, Shock Absorber

Remove bottom cover of seat with grab handle (HX model).

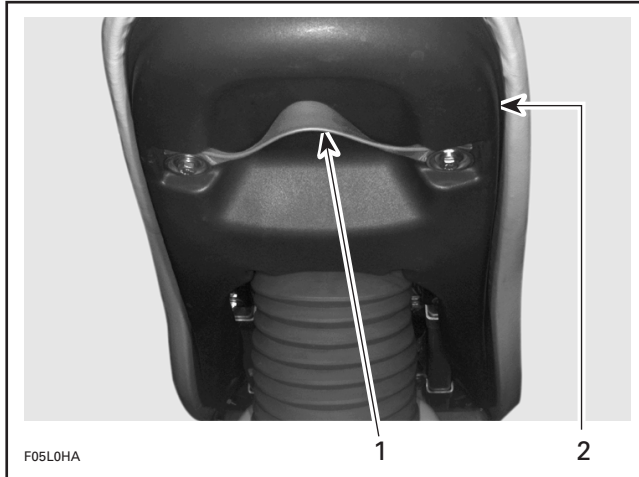

F05L0HA

TYPICAL — HX MODEL SHOWN

1. Grab handle
2. Cover

Loosen collar **no. 2** of outer boot **no. 3**, then pull outer boot downward.

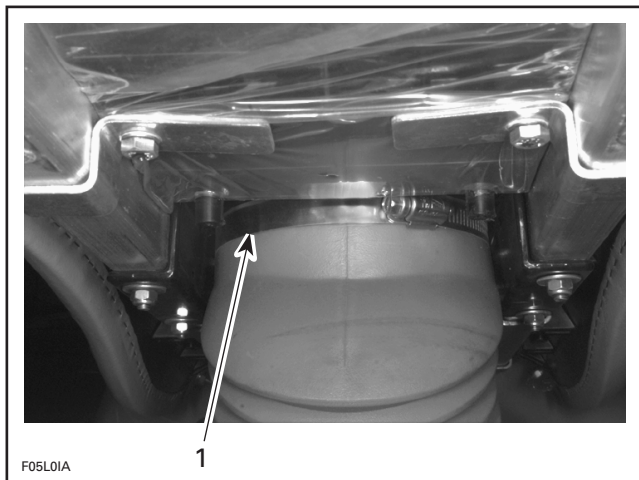

F05L0IA

1. Collar

Remove rear access panel from body.

From bilge, loosen lower collar **no. 4**, then push inner boot **no. 5** upward.

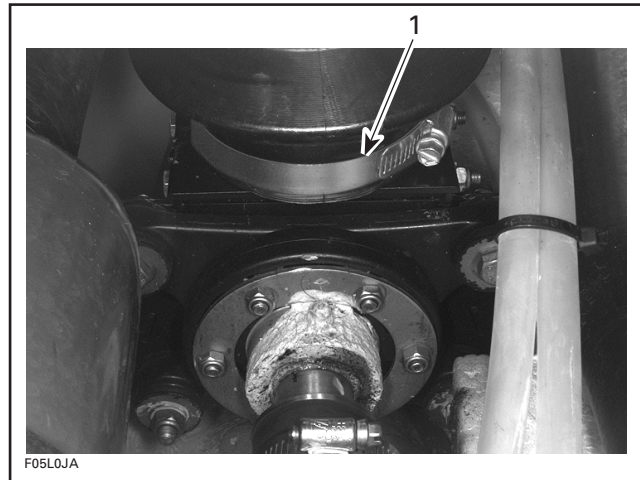

F05L0JA

1. Collar

Remove bolt **no. 6** and lock nut **no. 7** from shock absorber lower support **no. 8**.

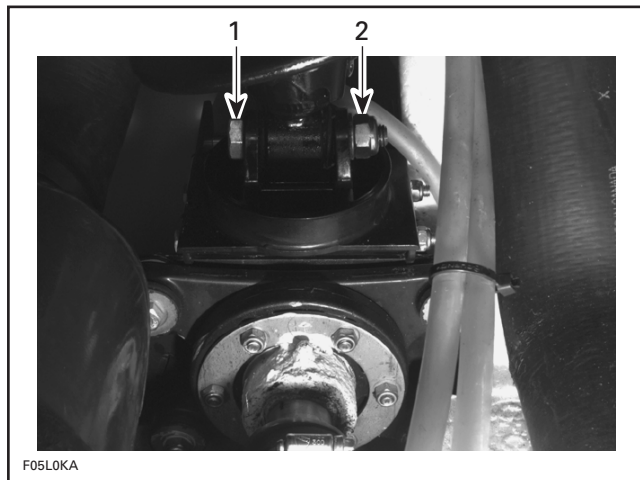

F05L0KA

1. Bolt
2. Lock nut

Tilt seat upward.

Loosen upper collar **no. 9** of inner boot **no. 5**; then, pull inner boot.

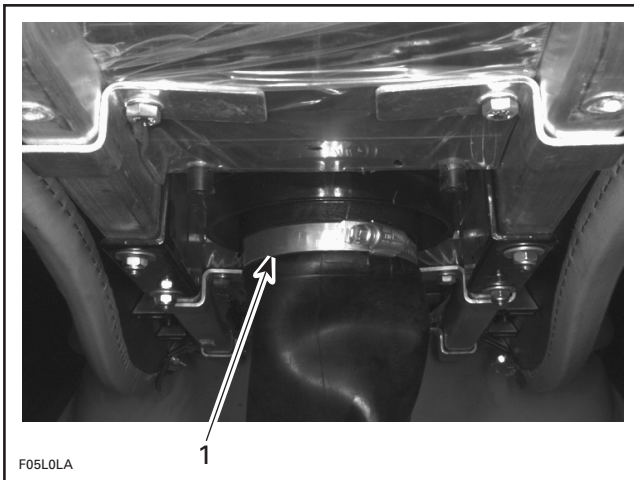

1. Collar

Remove bolt **no. 10** and lock nut **no. 11** from shock absorber upper support.

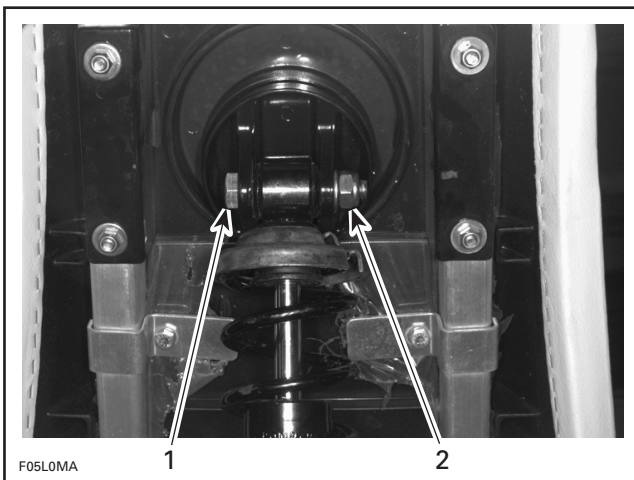

1. Bolt
2. Lock nut

Remove shock absorber/coil spring assembly.

3, Outer Boot

Pull outer boot to remove it from body.

12, Coil Spring

Install spring compressor tool (P/N 529 027 100) in a vise.

◆ WARNING
Do not attempt to dismantle a spring without using the proper tool.

Install shock absorber/coil spring assembly in spring compressor tool.



Compress spring and remove cup.

Unload tool and remove spring from shock absorber.

INSPECTION

3,5, Boot

Inspect condition of boots. If there is any tear, renew boot(s).

1, Shock Absorber

Inspect shock absorber for wear. Extend and compress the piston several times over its entire stroke; it should move smoothly and with uniform resistance.

Pay attention to the following conditions that will denote a defective shock absorber:

- A skip or a hang back when reversing stroke at mid travel.
- Seizing or binding condition except at extreme end of either stroke.
- Oil leakage.
- A gurgling noise, after completing one full compression and extension stroke.

Renew if any defects are present.

ASSEMBLY

Assembly is essentially the reverse of disassembly procedure. Refer to the main illustration at the beginning of this sub-section for torque specifications and service products to be used.

TABLE OF CONTENTS

ADJUSTMENT AND REPAIR	11-02-1
SEAT ADJUSTMENT	11-02-15
STORAGE COMPARTMENT COVER ADJUSTMENT	11-02-17
ACCESS PANEL ADJUSTMENT	11-02-17
INLET GRATE REMOVAL.....	11-02-18
RIDING PLATE.....	11-02-18
JET PUMP SUPPORT	11-02-19
DEFLECTOR	11-02-21
DRAIN PLUG INSTALLATION	11-02-21
SEAT REMOVAL.....	11-02-21
SEAT COVER REPLACEMENT	11-02-22
BUMPER REPLACEMENT	11-02-23
SPONSON REPLACEMENT	11-02-23
BAFFLE SEALING (GTS MODEL)	11-02-24
HOOD REMOVAL.....	11-02-24
DECALS REPLACEMENT	11-02-24
HULL AND BODY REPAIR	11-02-25
TOOLS AND MATERIALS LIST	11-02-27
HULL INSERT REPAIR	11-02-28

ADJUSTMENT AND REPAIR

SP and SPX Models

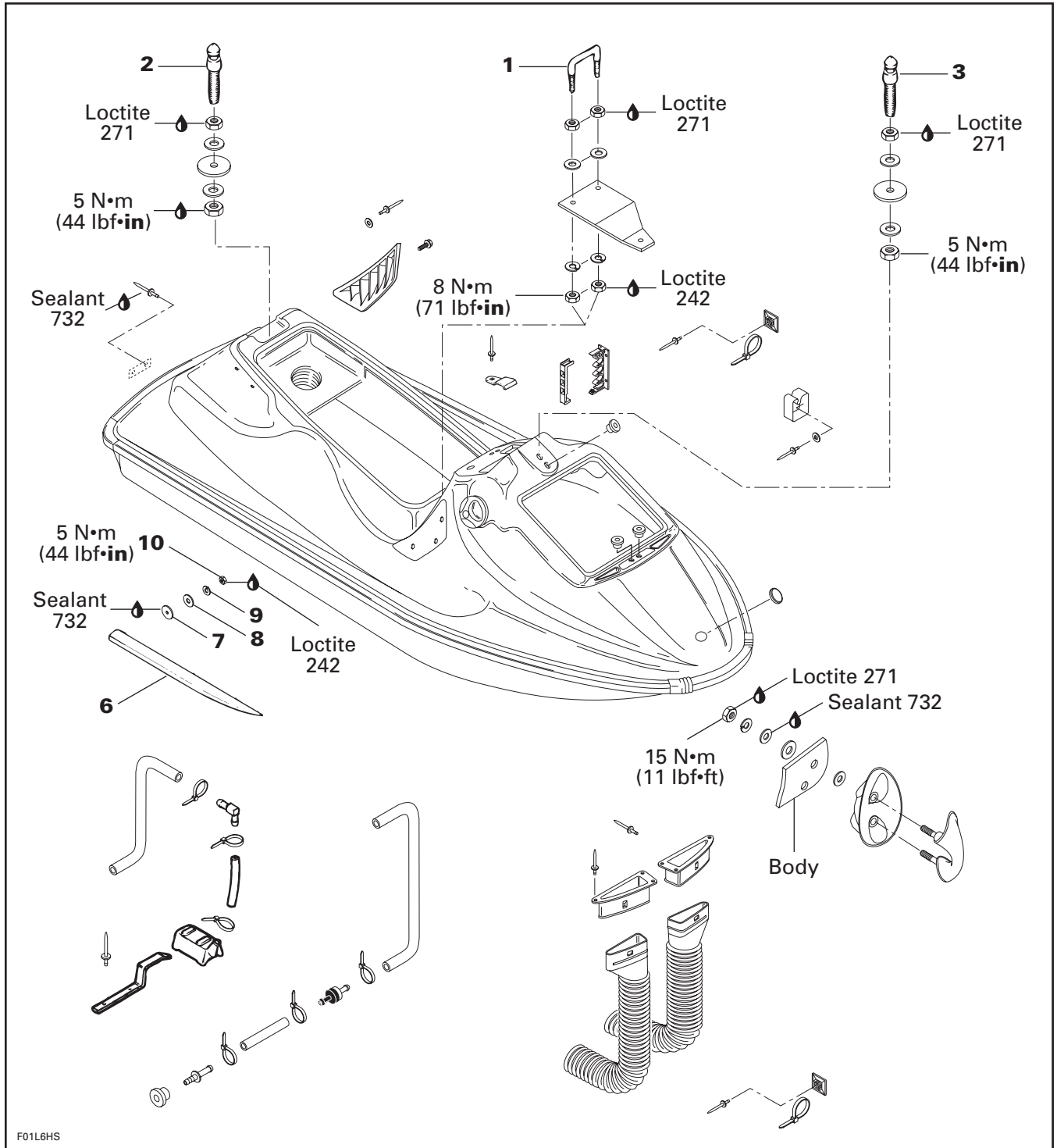

Section 11 HULL/BODY

Sub-Section 02 (ADJUSTMENT AND REPAIR)

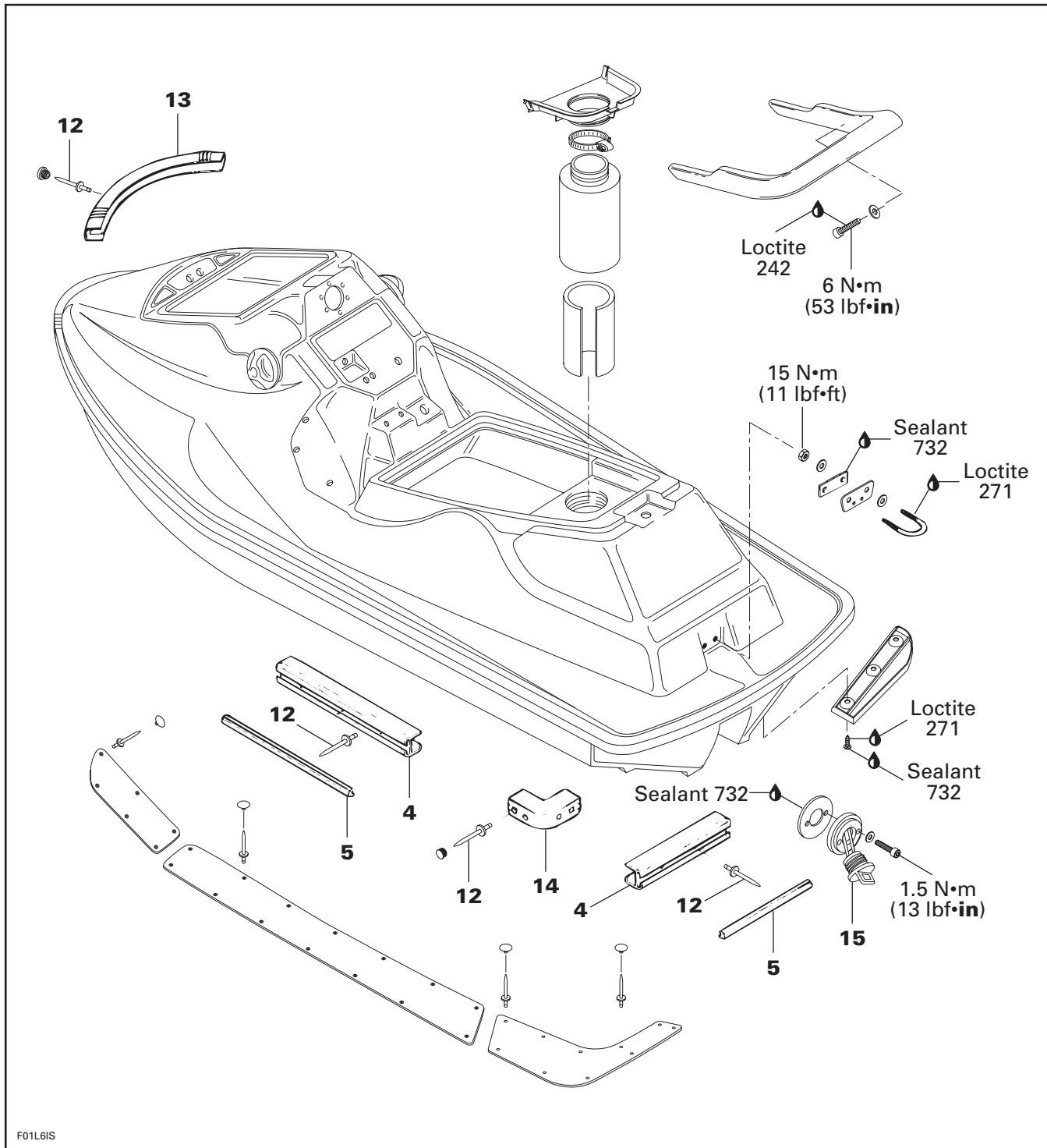

F01L6IS

Section 11 HULL/BODY
Sub-Section 02 (ADJUSTMENT AND REPAIR)

GTS Model

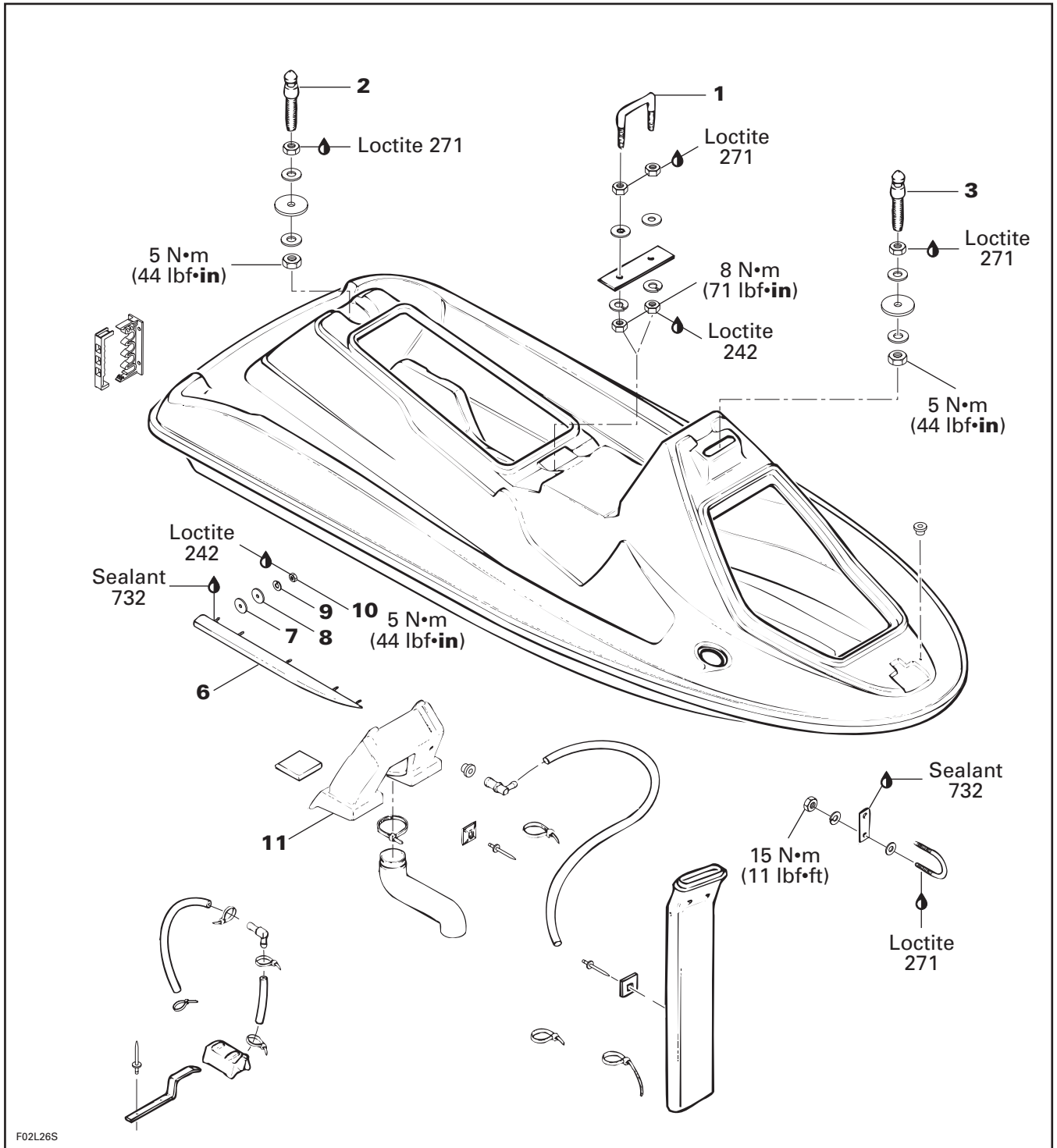

F02L26S

Section 11 HULL/BODY

Sub-Section 02 (ADJUSTMENT AND REPAIR)

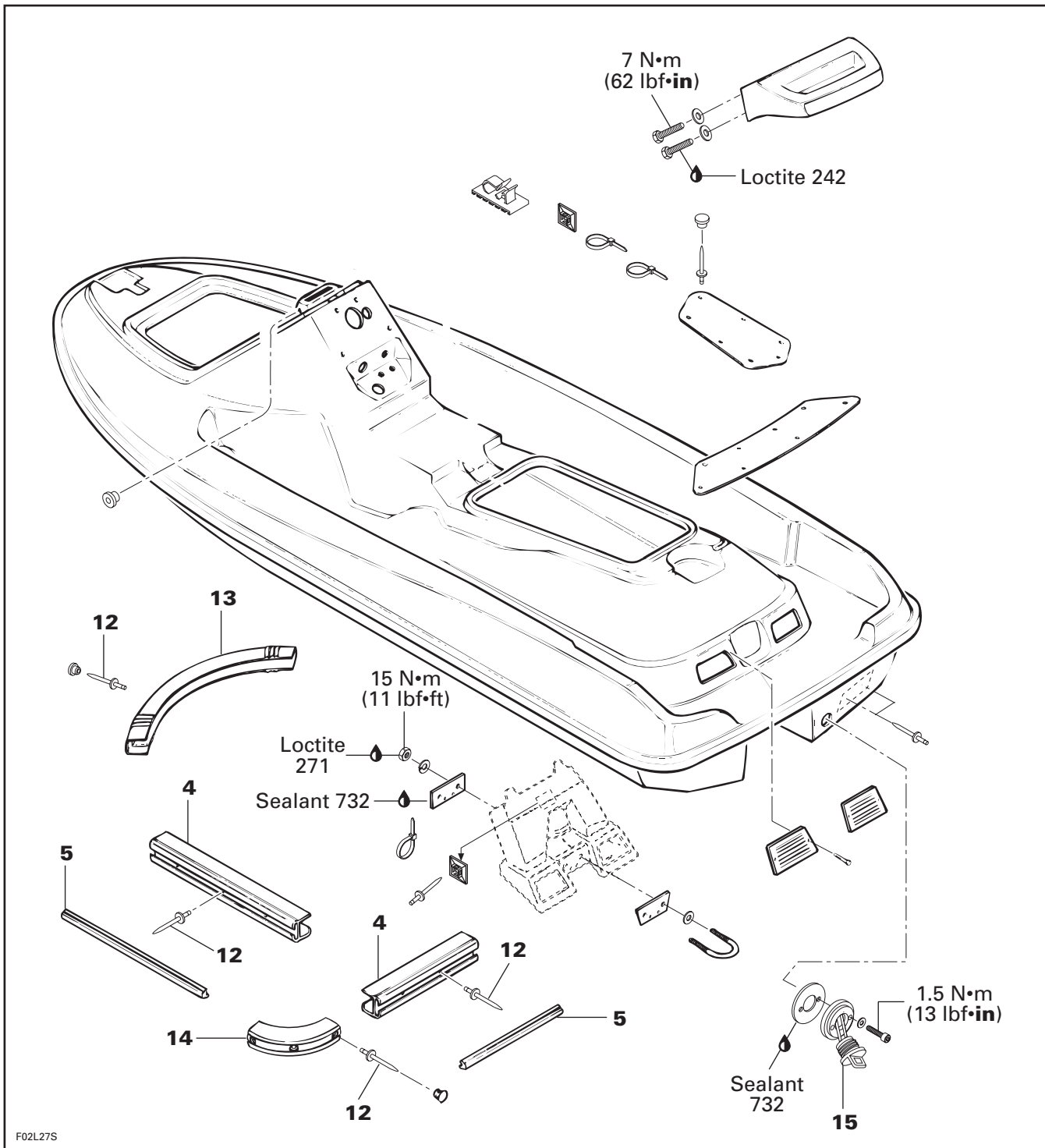

Section 11 HULL/BODY

Sub-Section 02 (ADJUSTMENT AND REPAIR)

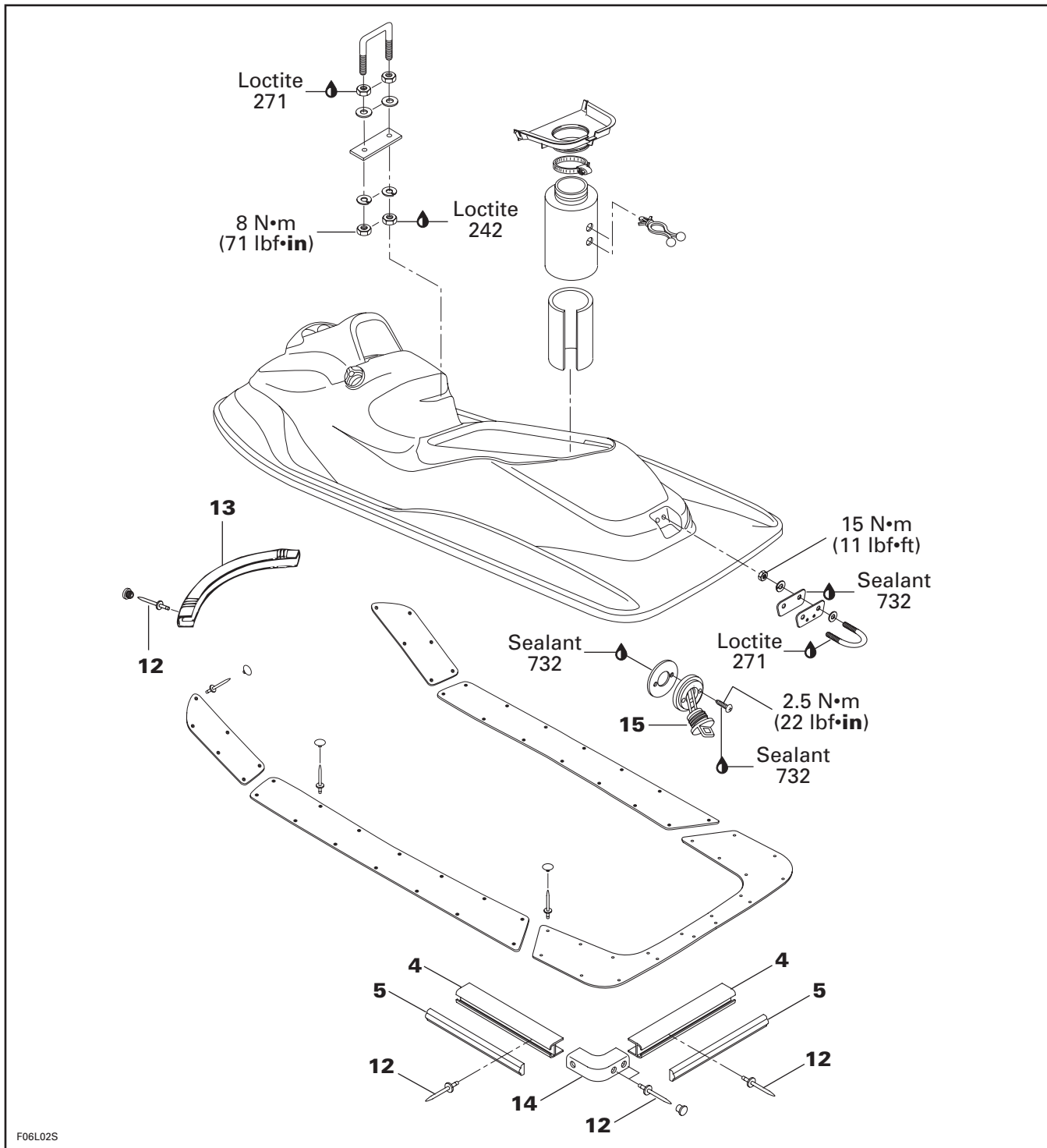

F06L02S

GTI and GTX Models

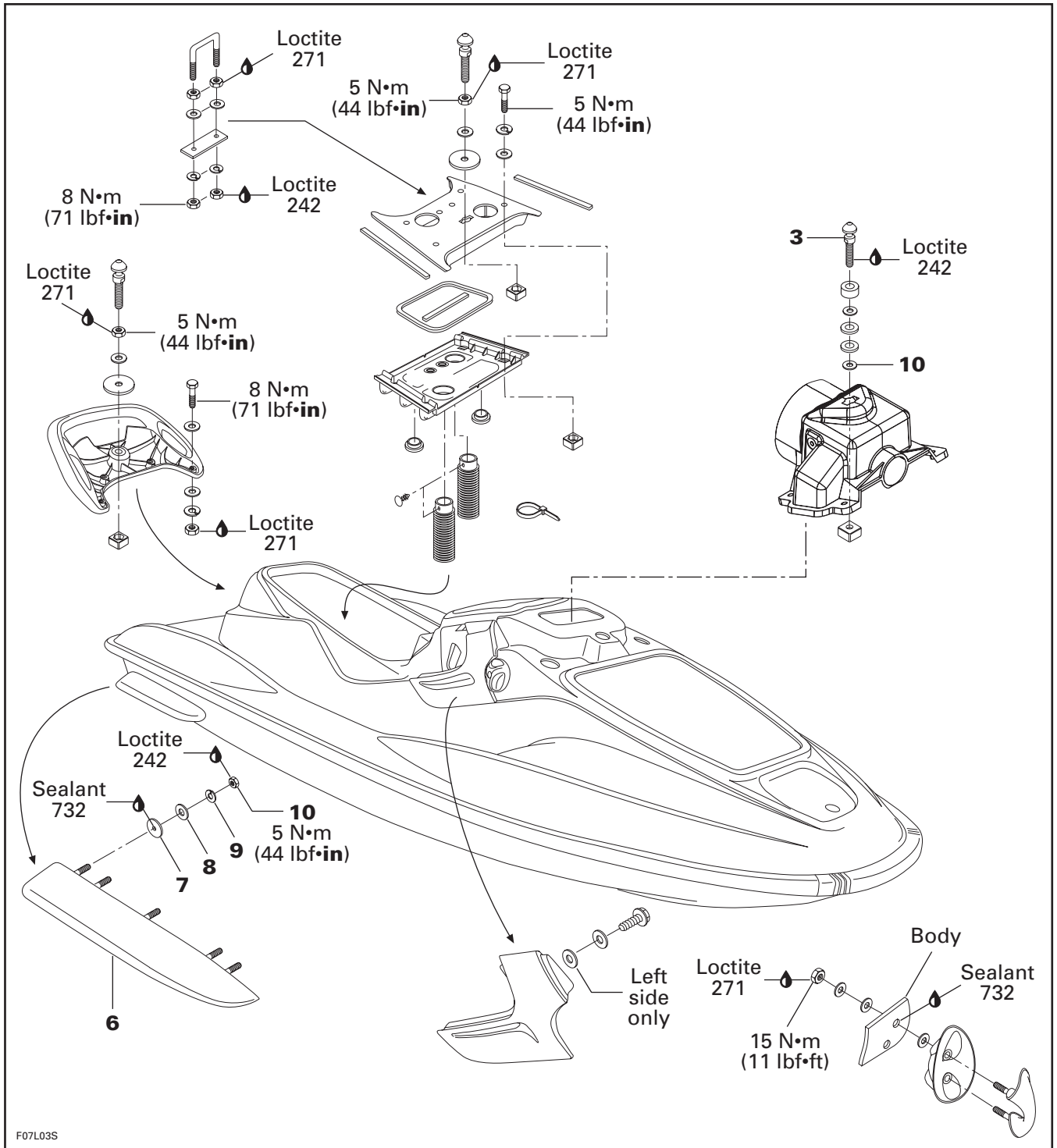

Section 11 HULL/BODY

Sub-Section 02 (ADJUSTMENT AND REPAIR)

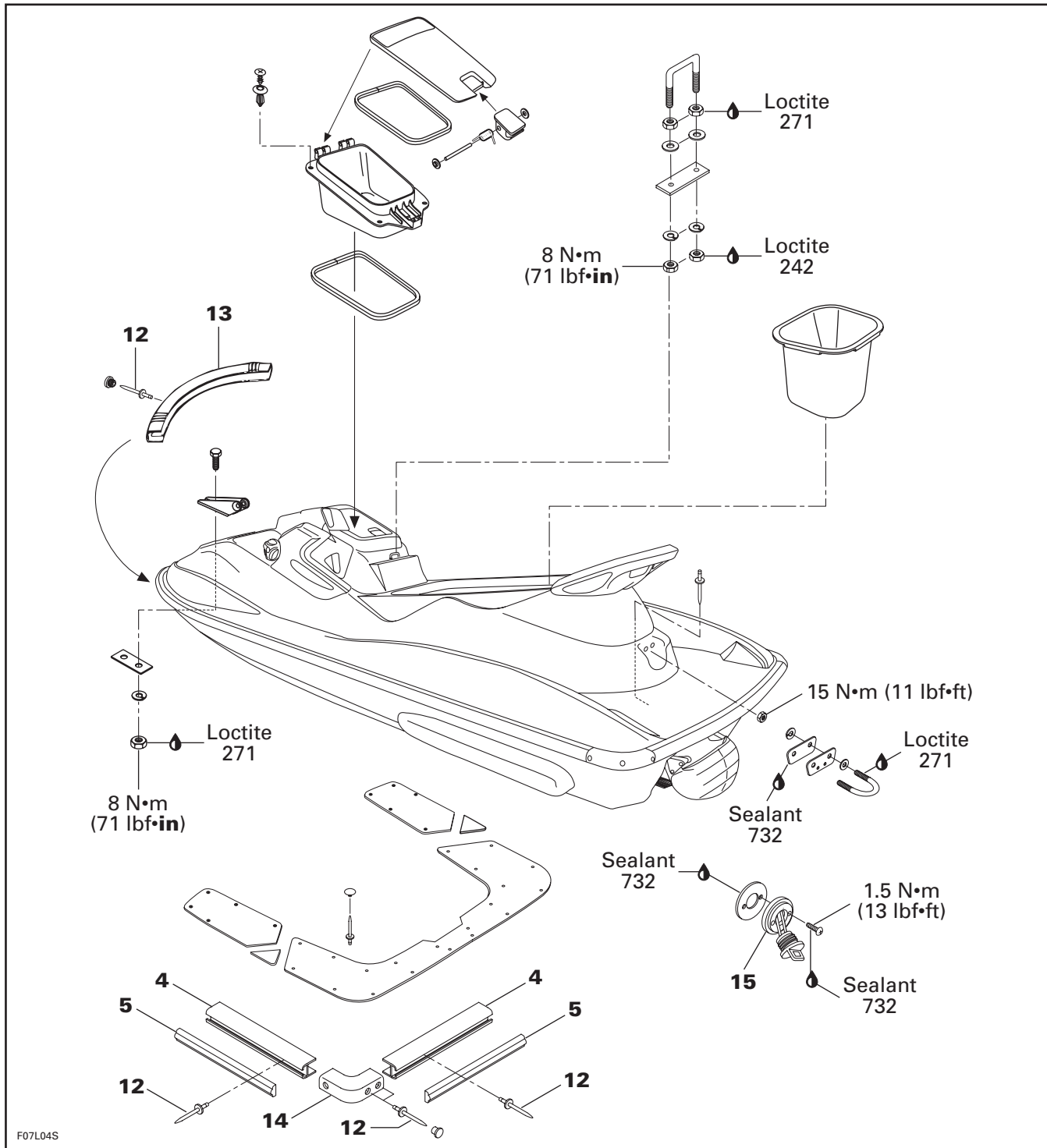

Section 11 HULL/BODY
Sub-Section 02 (ADJUSTMENT AND REPAIR)

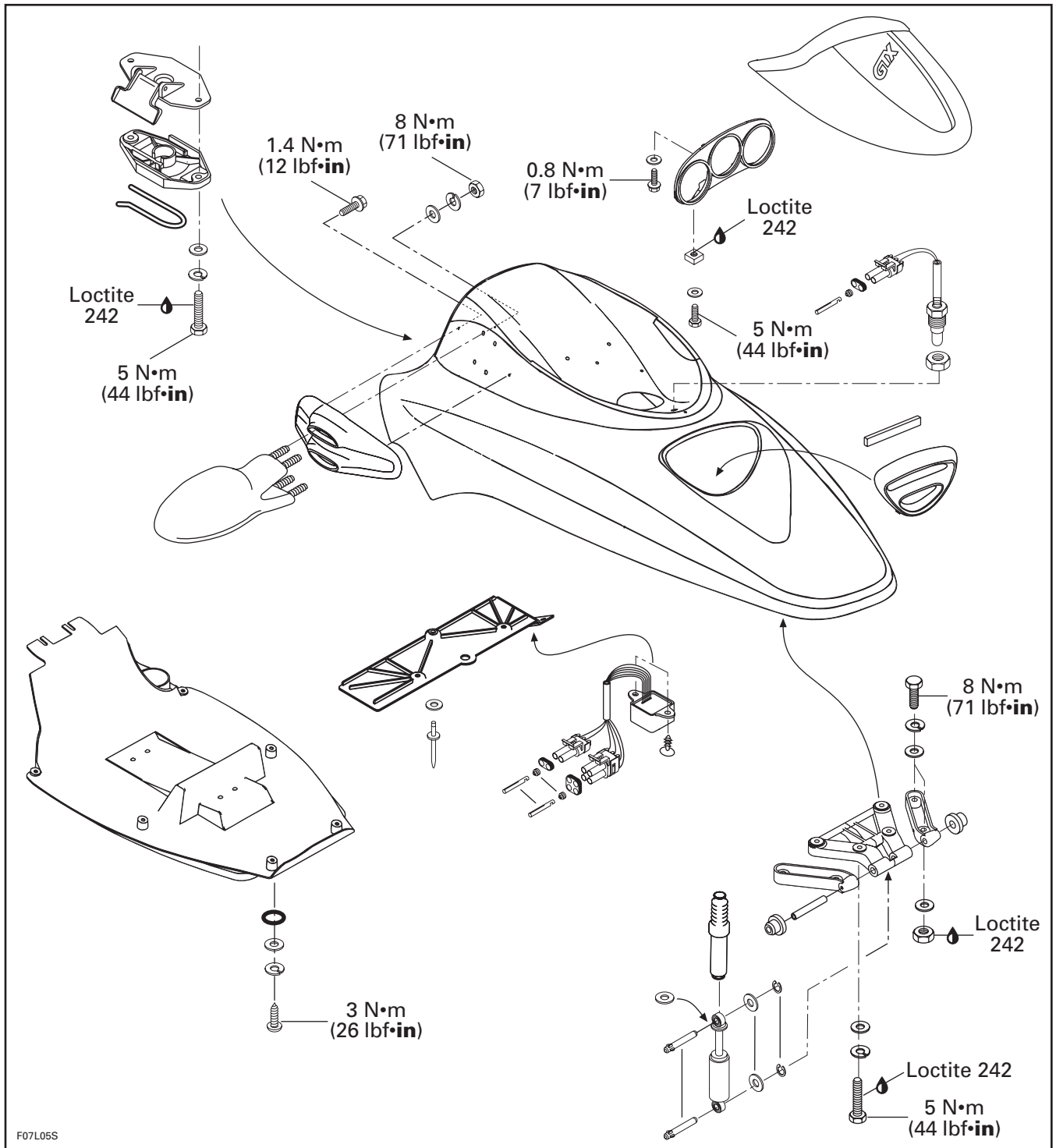

F07L05S

Section 11 HULL/BODY

Sub-Section 02 (ADJUSTMENT AND REPAIR)

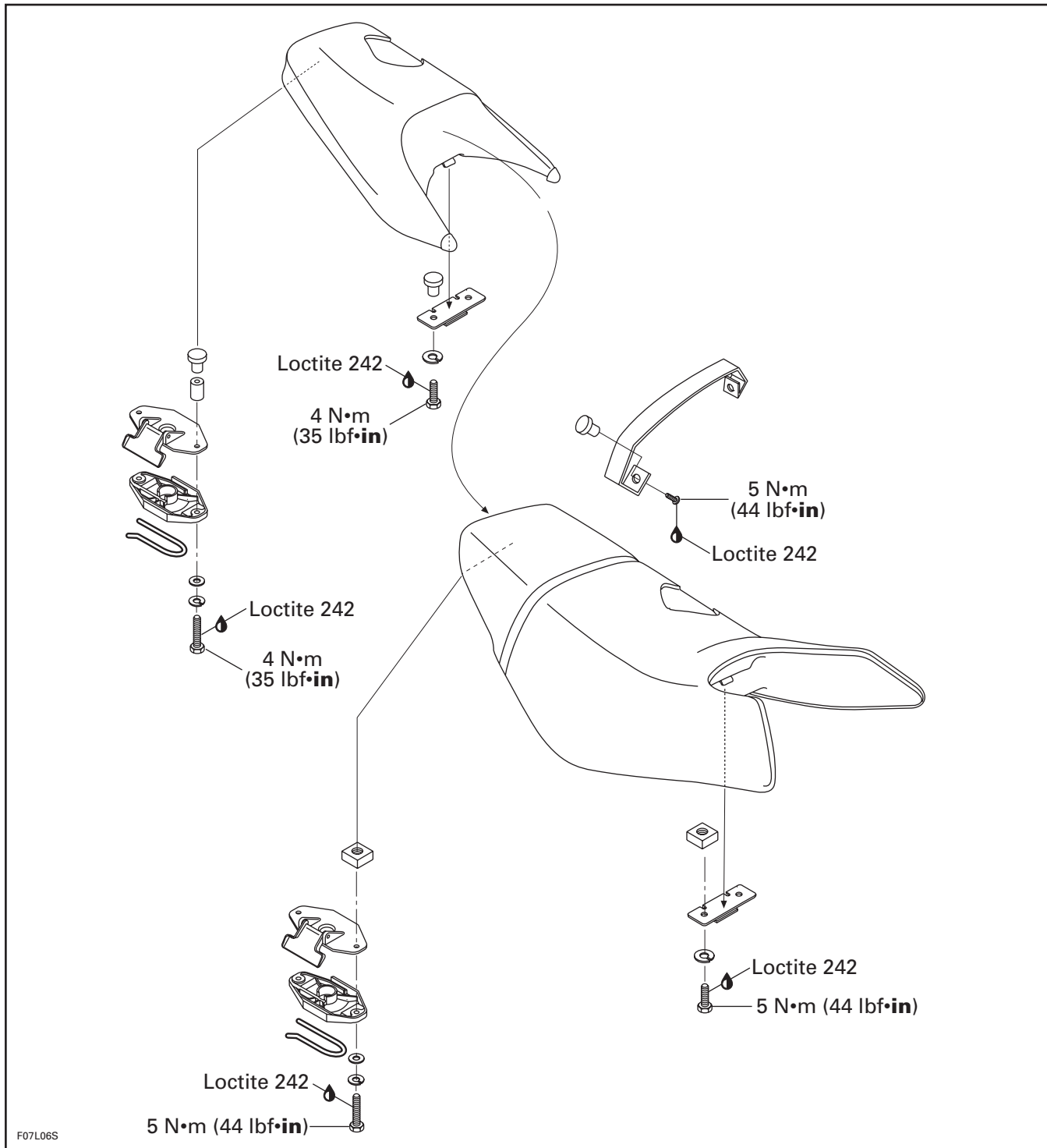

Section 11 HULL/BODY
Sub-Section 02 (ADJUSTMENT AND REPAIR)

HX Model

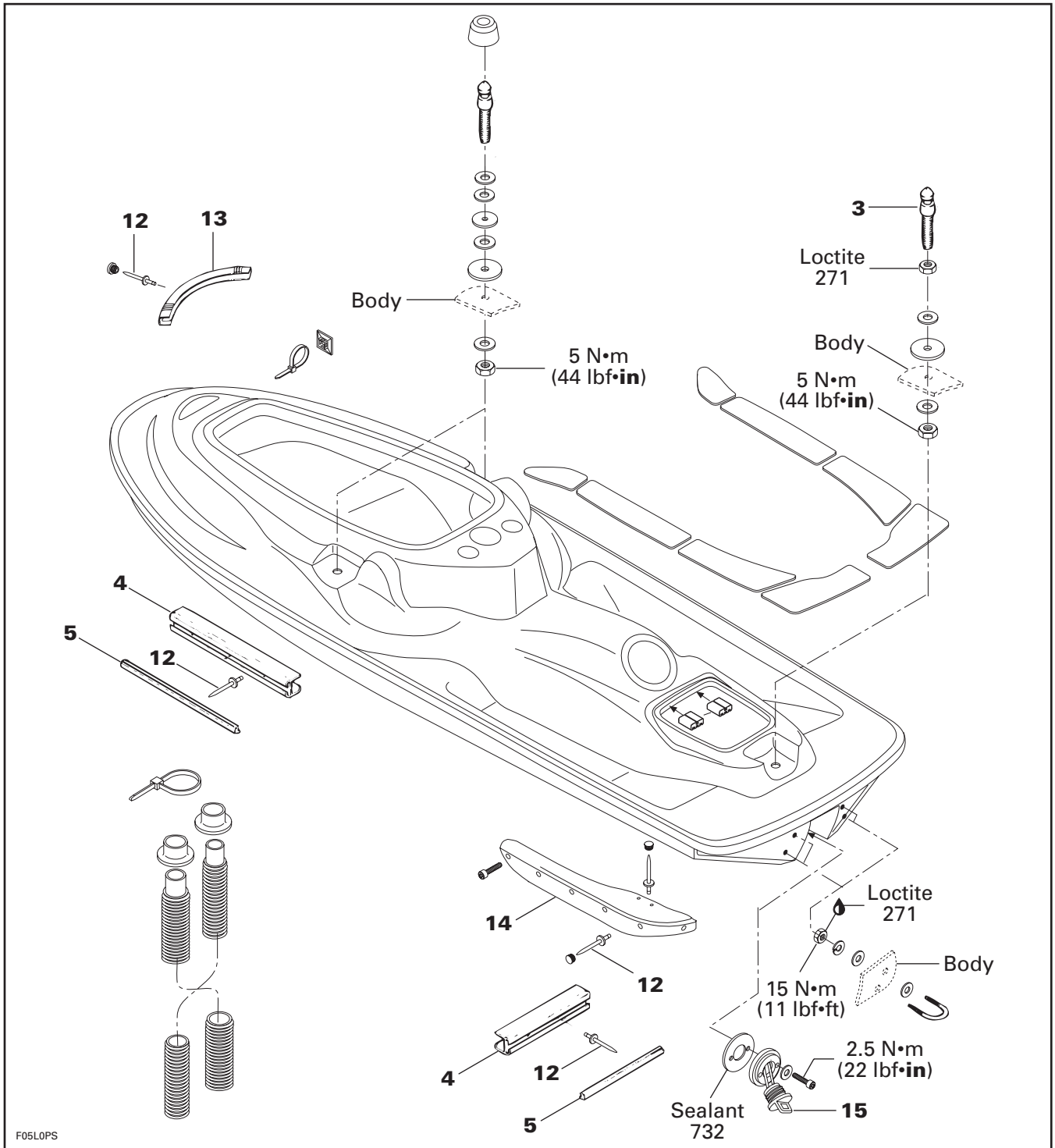

Section 11 HULL/BODY

Sub-Section 02 (ADJUSTMENT AND REPAIR)

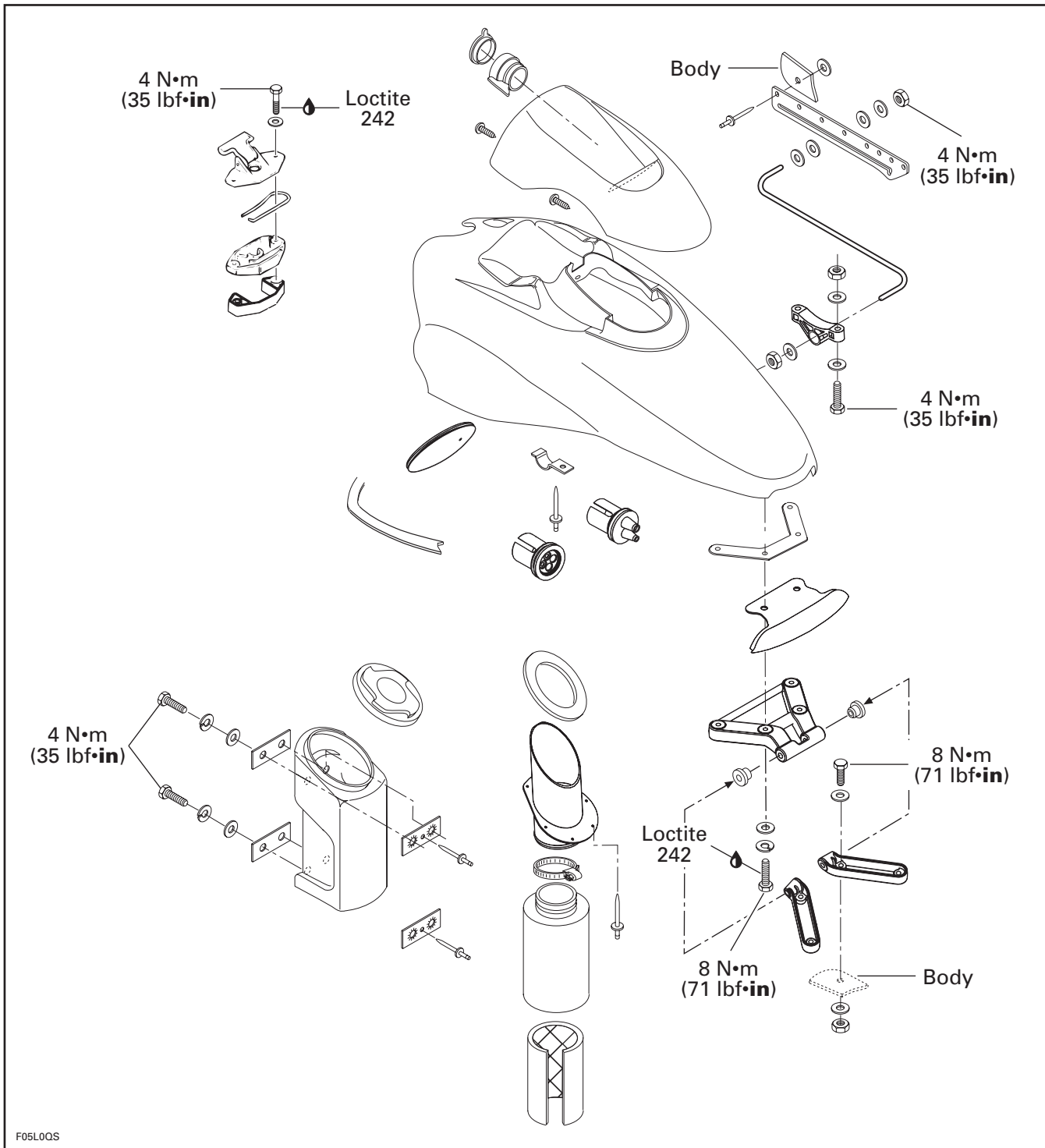

F05L00S

Section 11 HULL/BODY
Sub-Section 02 (ADJUSTMENT AND REPAIR)

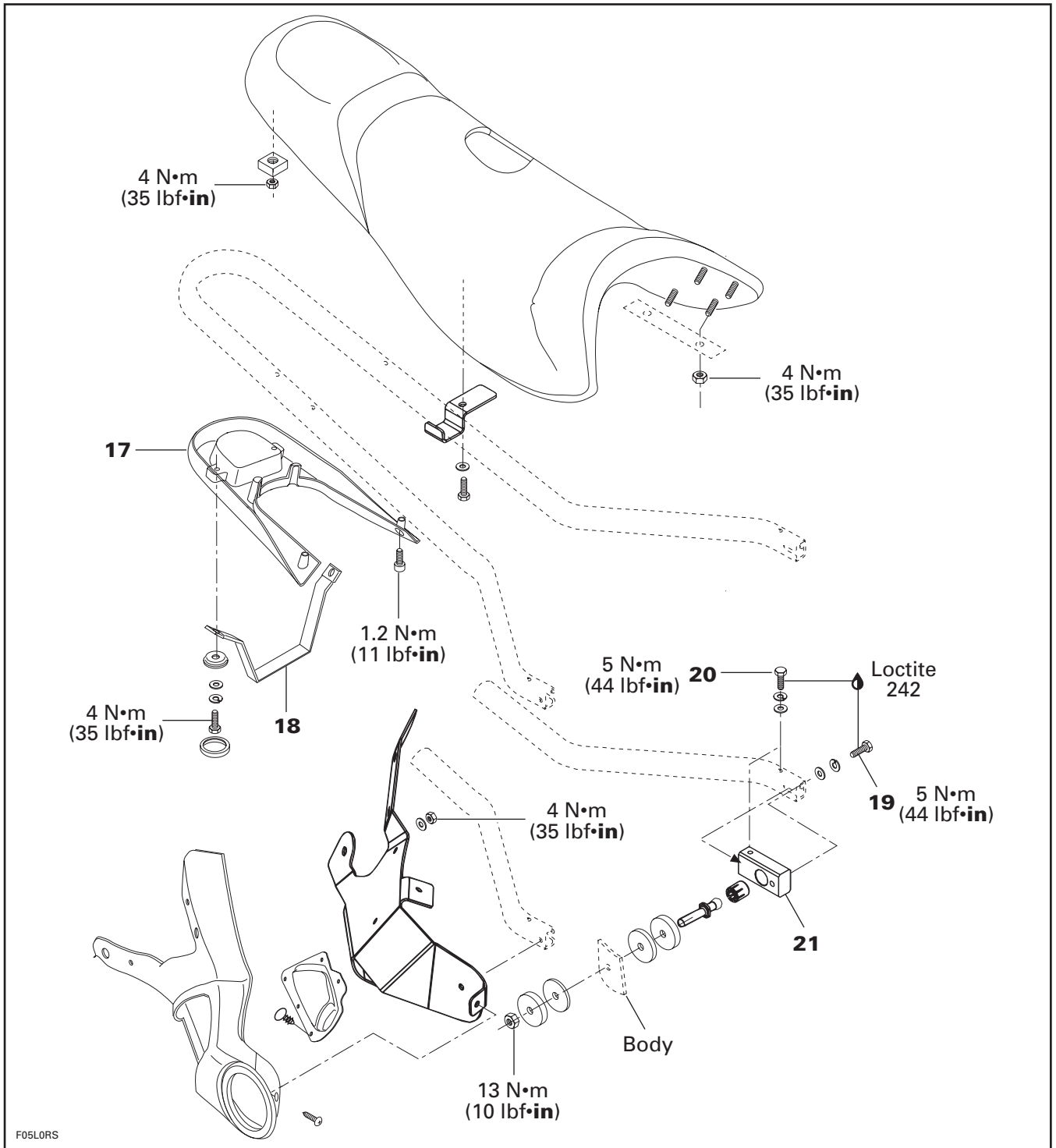

Section 11 HULL/BODY

Sub-Section 02 (ADJUSTMENT AND REPAIR)

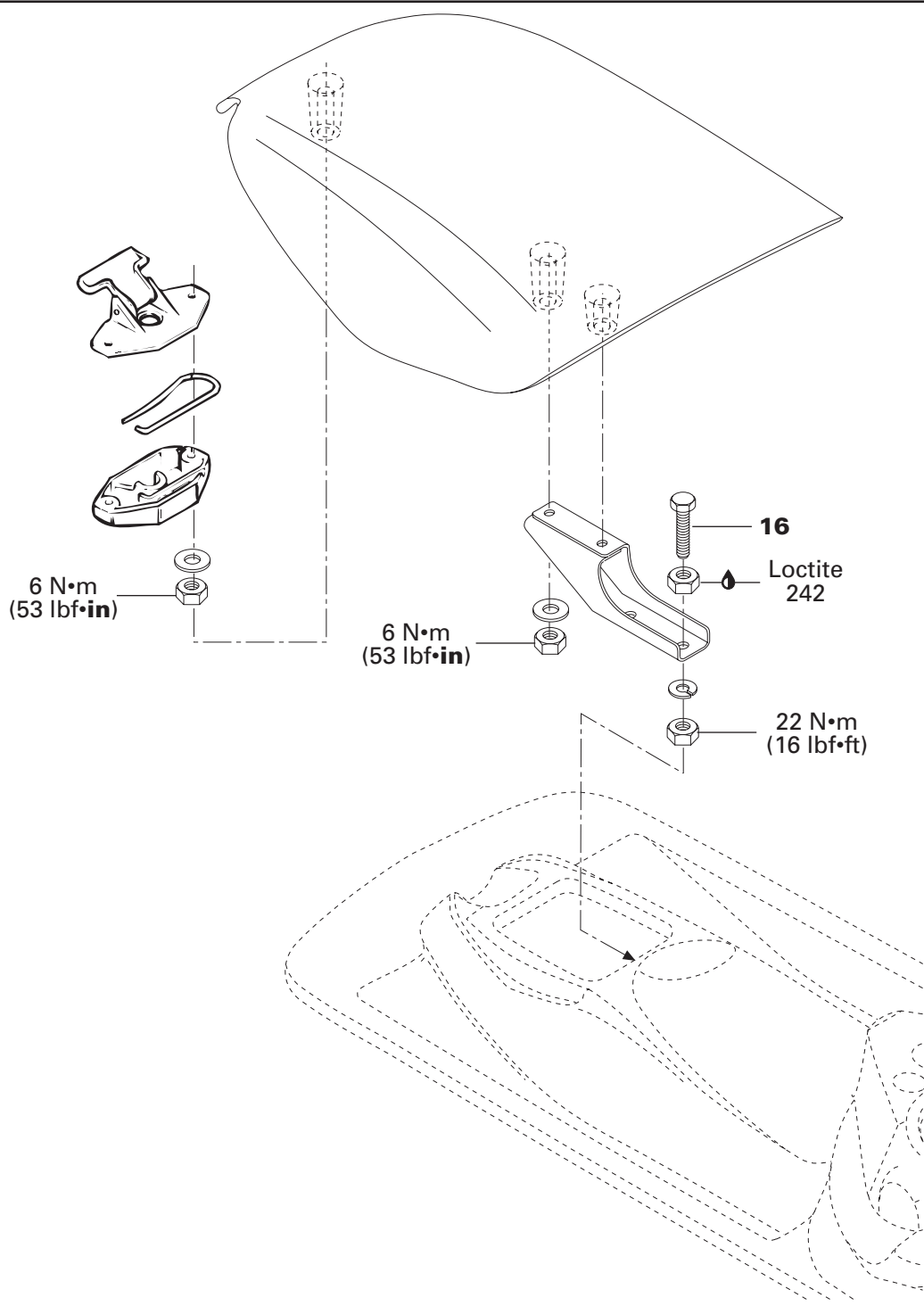

F05LOSS

SEAT ADJUSTMENT

All Models Except the HX and XP

Adjust seat retainer no. 1 as per following specifications:

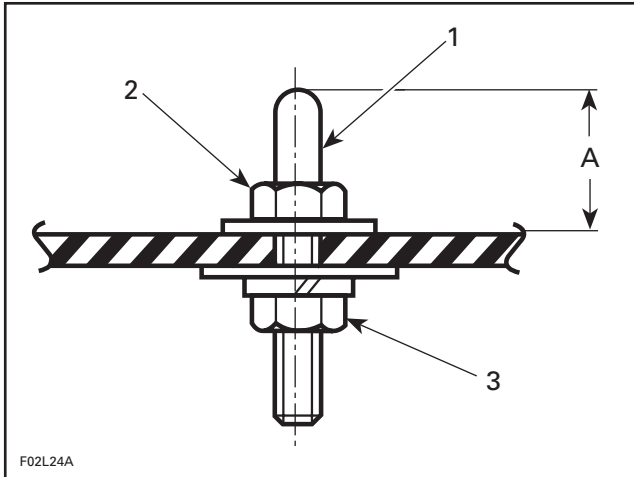

SP, SPX, GTI AND GTX MODELS

1. Seat retainer
2. Adjustment nut (Loctite 271)
3. Nut (Loctite 242). Torque to 8 N•m (71 lbf•in)
- A. 25 ± 1 mm ($63/64 \pm 3/64$ in)

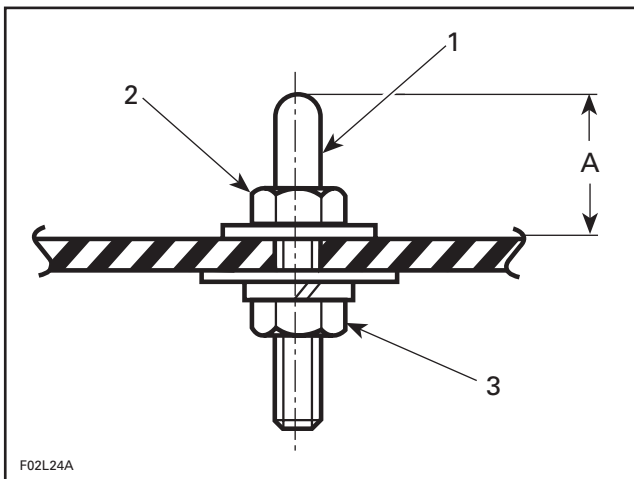

GS, GSI AND GSX MODELS

1. Seat retainer
2. Adjustment nut (apply Loctite 271)
3. Nut (apply Loctite 242 and torque to 8 N•m (71 lbf•in)
- A. 21 ± 1 mm ($53/64 \pm 3/64$ in)

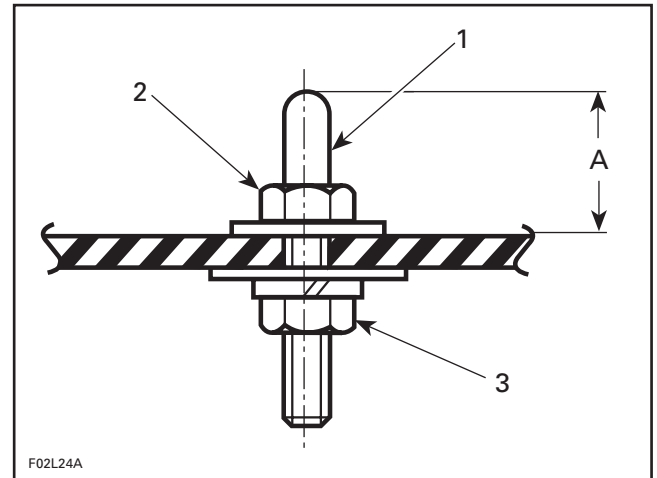

GTS MODEL

1. Front hook
2. Adjustment nut (Loctite 271)
3. Nut (Loctite 242). Torque to 8 N•m (71 lbf•in)
- A. $22.5 (+1, -0)$ mm ($51/64 (+1/32, -0)$ in)

Adjust lock pin no. 2 as per following specifications:

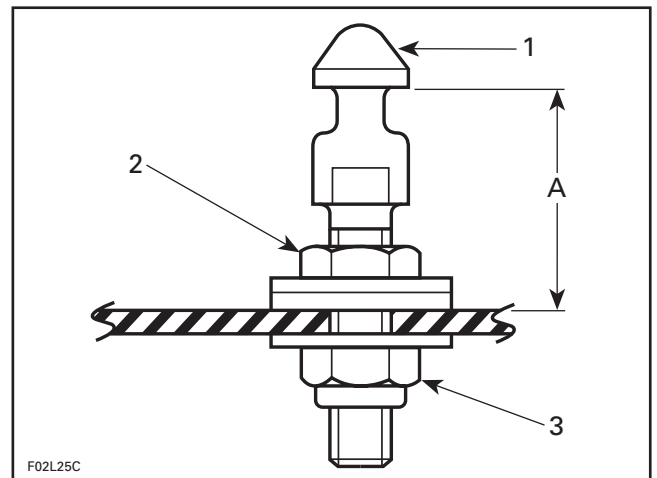

SP AND SPX MODELS

1. Lock pin
2. Adjustment nut (Loctite 271)
3. Lock nut. Torque to 5 N•m (44 lbf•in)
- A. 37 ± 1 mm ($1-29/64 \pm 3/64$ in)

Section 11 HULL/BODY

Sub-Section 02 (ADJUSTMENT AND REPAIR)

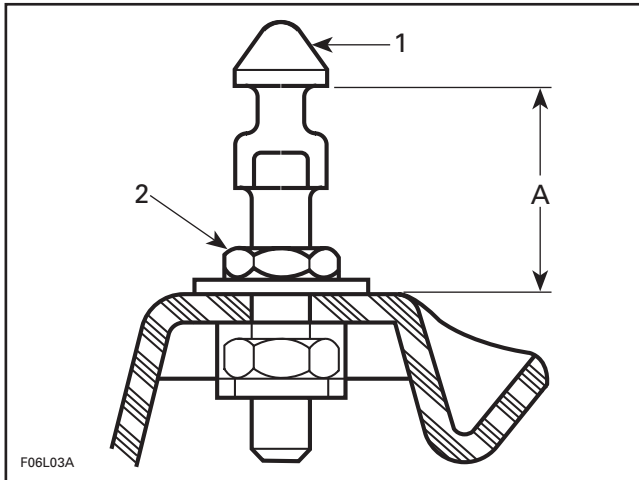

GS, GSI AND GSX MODELS

1. Lock pin
 2. Adjustment nut (apply Loctite 271)
- A. $33.5 \pm 1 \text{ mm}$ ($1\text{-}5/16 \pm 3/64 \text{ in}$)

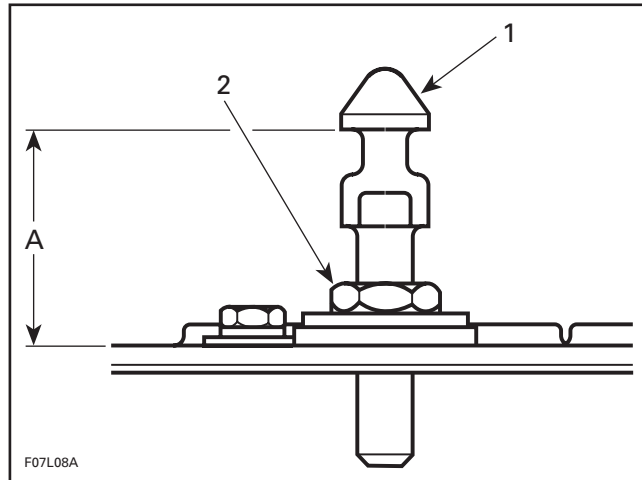

GTI AND GTX MODELS — FRONT SEAT

1. Lock pin
 2. Adjustment nut (Loctite 271)
- A. $39 \pm 1 \text{ mm}$ ($1\text{-}35/64 \pm 3/64 \text{ in}$)

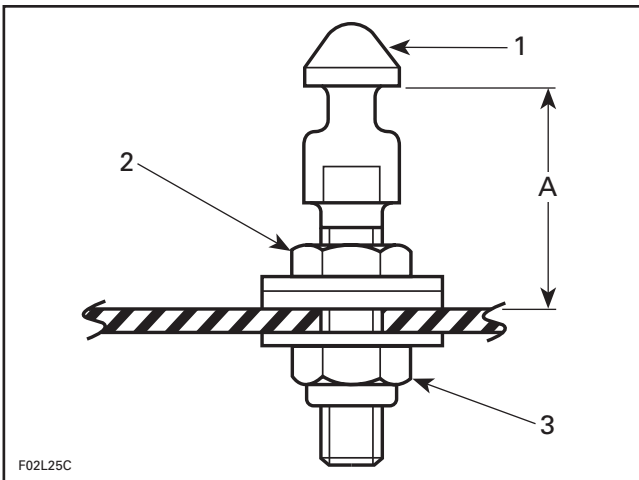

GTS MODEL

1. Lock pin
 2. Adjustment nut (Loctite 271)
 3. Lock nut. Torque to $5 \text{ N}\cdot\text{m}$ ($44 \text{ lbf}\cdot\text{in}$)
- A. $38 \pm 1 \text{ mm}$ ($1\text{-}1/2 \pm 3/64 \text{ in}$)

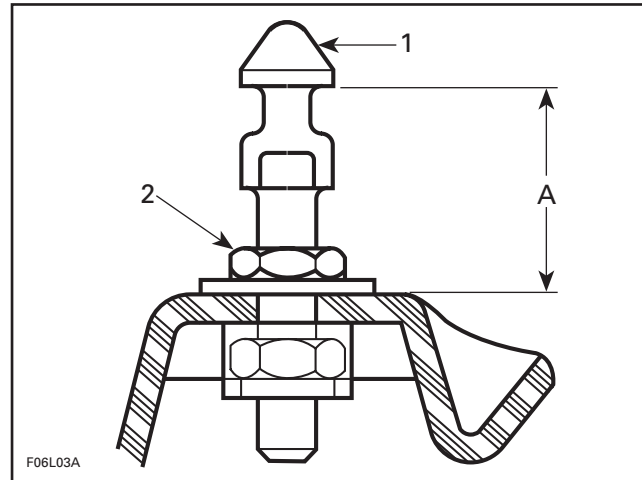

GTI AND GTX MODELS — REAR SEAT

1. Lock pin
 2. Adjustment nut (apply Loctite 271)
- A. $33.5 \pm 1 \text{ mm}$ ($1\text{-}5/16 \pm 3/64 \text{ in}$)

STORAGE COMPARTMENT COVER ADJUSTMENT

All Models Except the HX and XP

Adjust lock pin no. 3 as per following specifications:

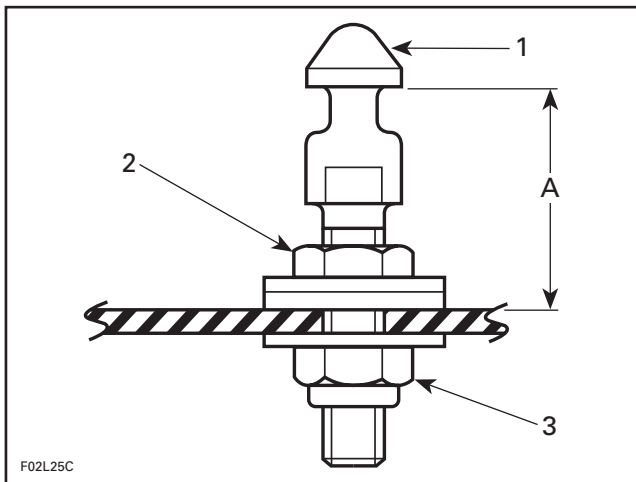

SP, SPX AND GTS MODELS

1. Lock pin
2. Adjustment nut (Loctite 271)
3. Lock nut. Torque to 5 N•m (44 lbf•in)
- A. 37 ± 1 mm (1-29/64 \pm 3/64 in)

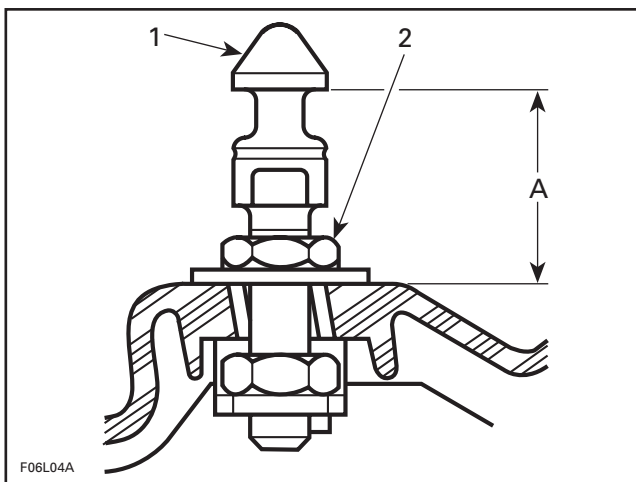

GS, GSI AND GSX MODELS

1. Lock pin (apply Loctite 271)
2. Adjustment nut
- A. 34 ± 1 mm (1-11/32 \pm 3/64 in)

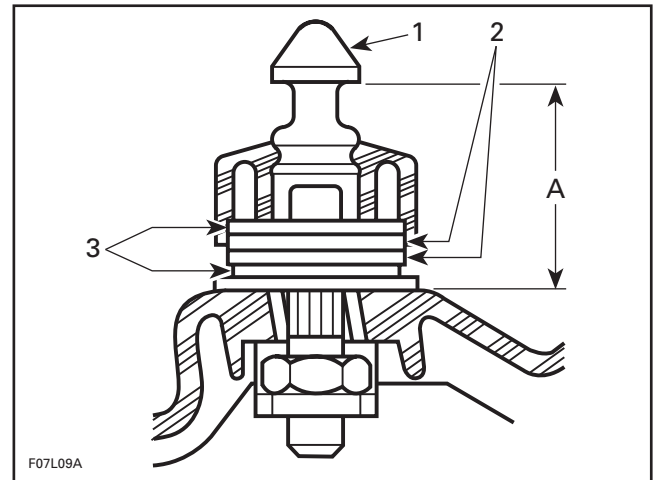

GTI AND GTX MODELS

1. Lock pin (apply Loctite 242)
2. Rubber washer
3. Flat washers
- A. 39.2 ± 1 mm (1-35/64 \pm 3/64 in)

NOTE: The GTI and GTX models have a floating type lock pin. It is normal to have a front and aft play of the lock pin. To adjust, tighten lock pin until any vertical play is eliminated. Make sure a front and aft play remains when pressing by hands.

ACCESS PANEL ADJUSTMENT

HX Model Only

Adjust lock pin no. 3 of access panel as per following specifications:

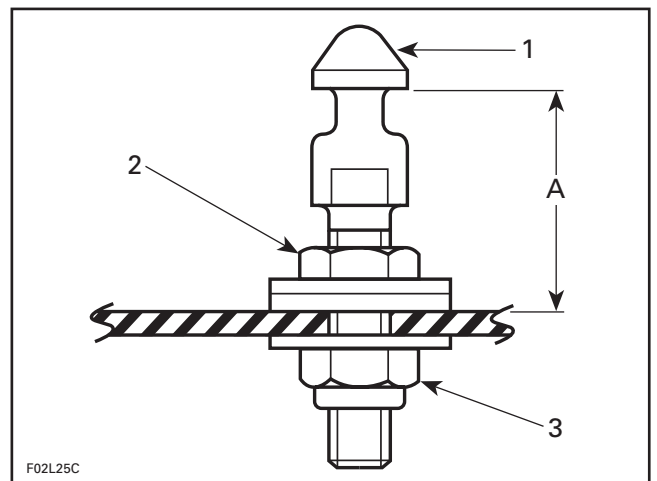

1. Lock pin
2. Adjustment nut (Loctite 271)
3. Lock nut. Torque to 5 N•m (44 lbf•in)
- A. 37 ± 1 mm (1-29/64 \pm 3/64 in)

Section 11 HULL/BODY

Sub-Section 02 (ADJUSTMENT AND REPAIR)

Adjust bolts no. 16 of access panel arms as per following specifications:

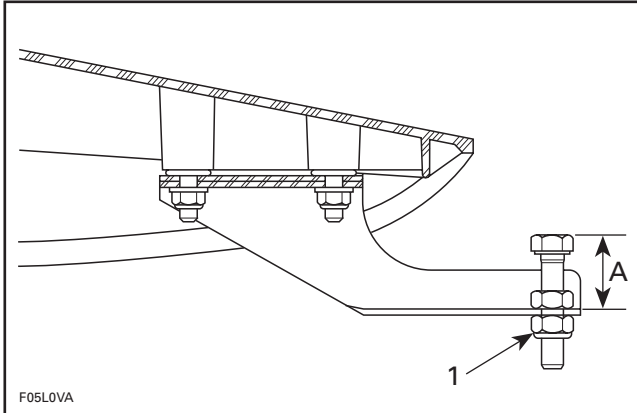

1. Lock nut. Torque to 22 N•m (16 lbf•ft)
A. 32 ± 1 mm ($1-17/64 \pm 3/64$ in)

INLET GRATE REMOVAL

Loosen screws and remove inlet grate.

NOTE: An impact screwdriver should be used to loosen tight screws.

RIDING PLATE

Removal

Remove inlet grate.

Remove jet pump. Refer to PROPULSION SYSTEM 08-02.

Remove the speed sensor from the riding plate (if applicable).

Loosen riding plate screws.

NOTE: An impact screwdriver should be used to loosen tight screws.

Using a low height hydraulic bottle jack and 2 steel plates, pry out riding plate.

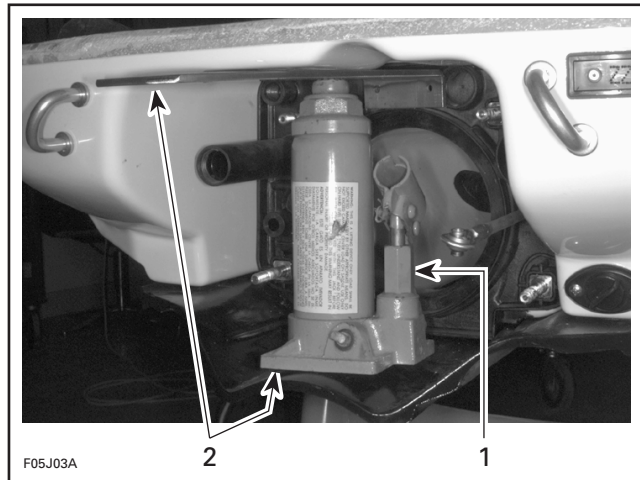

TYPICAL

1. Hydraulic bottle jack
2. Steel plates

Installation

Apply Loctite 598 Ultra Black as indicated by the shaded areas in the next illustrations. Follow also the torquing sequence (if applicable) as shown in the same illustrations.

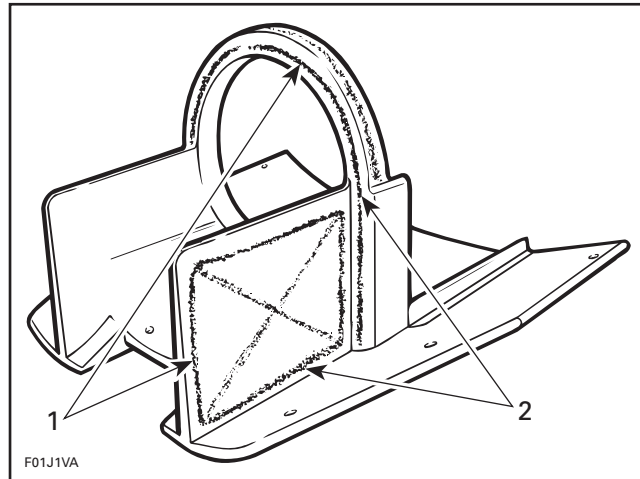

SP, SPX AND GTS MODELS

1. Apply Loctite 598 Ultra Black as indicated by the shaded area

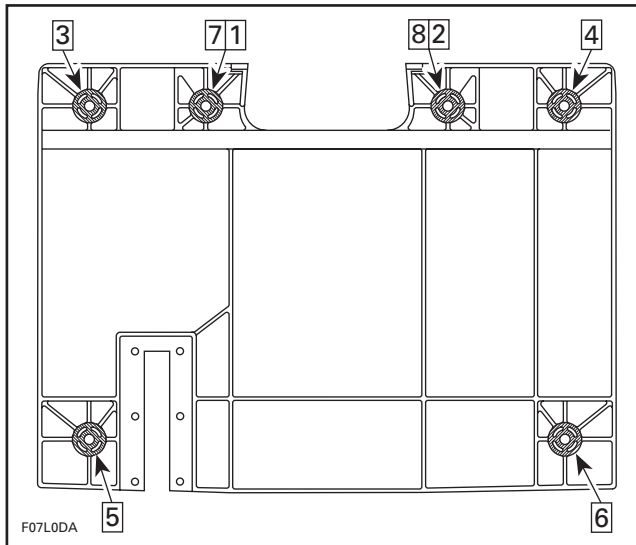

GS, GSI, GSX, GTI AND GTX MODELS

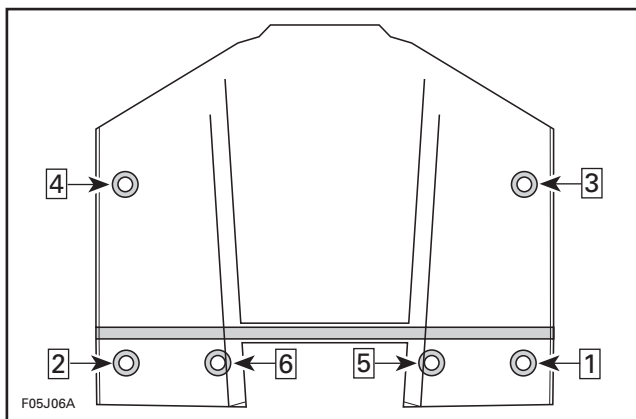

HX MODEL

JET PUMP SUPPORT

GS, GSI, GSX, GTI, GTX, XP and HX Models

Removal

Remove jet pump. Refer to PROPULSION SYSTEM 08-02.

Remove inlet grate and riding plate.

Remove ball joint, boot, nut, half rings and O-rings from steering cable.

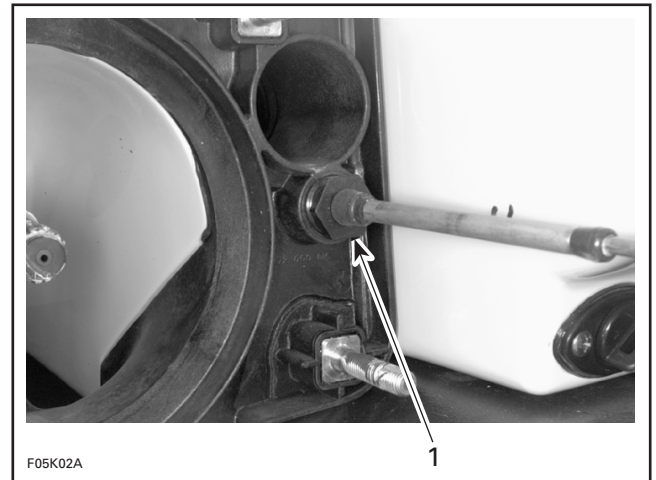

TYPICAL

1. Unscrew nut

Remove ball joint, boot, nut, half rings and O-rings from reverse cable (GTI and GTX models).

Remove boot and nut from VTS sliding shaft (XP, GSI and GSX models).

Disconnect water supply hose, water return hose and bailer hoses.



TYPICAL — HX MODEL SHOWN

HX Model Only

Disconnect engine drain hose.

Disconnect engine exhaust hose.

Section 11 HULL/BODY

Sub-Section 02 (ADJUSTMENT AND REPAIR)

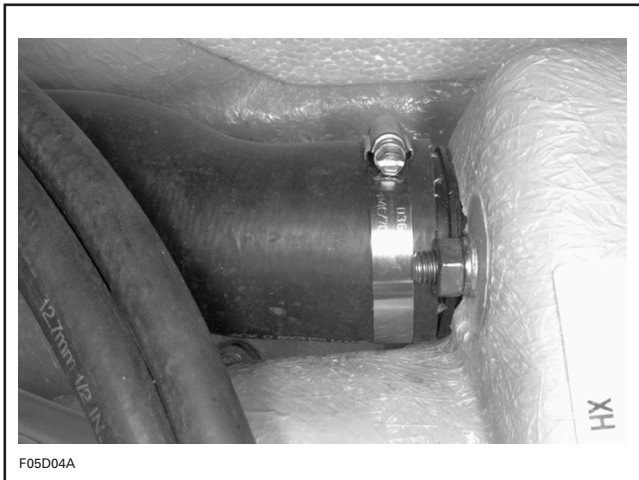

GS, GSI, GSX, GTI, GTX, XP and HX Models

Remove nuts, lock washers and flat washers retaining jet pump support.

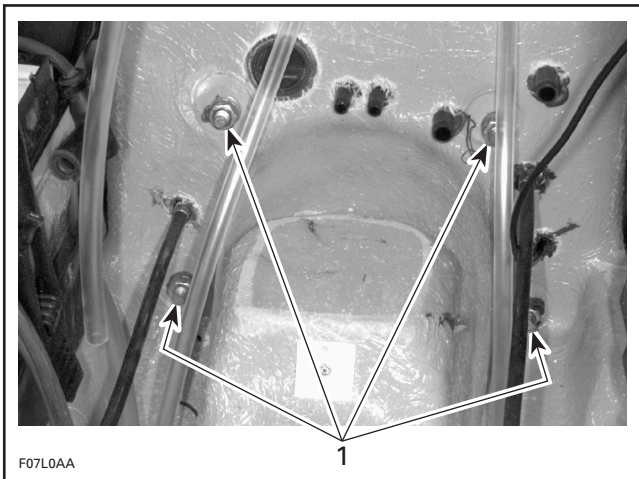

TYPICAL — GTX MODEL SHOWN

1. Remove nuts

Using a heat gun, heat jet pump support until it is possible to pull it.

NOTE: Shims may have been installed between support and body. Do not remove these shims, otherwise jet pump alignment will be altered.

Installation

Apply Loctite 598 Ultra Black as indicated by the shaded areas in the next illustrations. Follow also the torquing sequence as shown in the same illustrations.

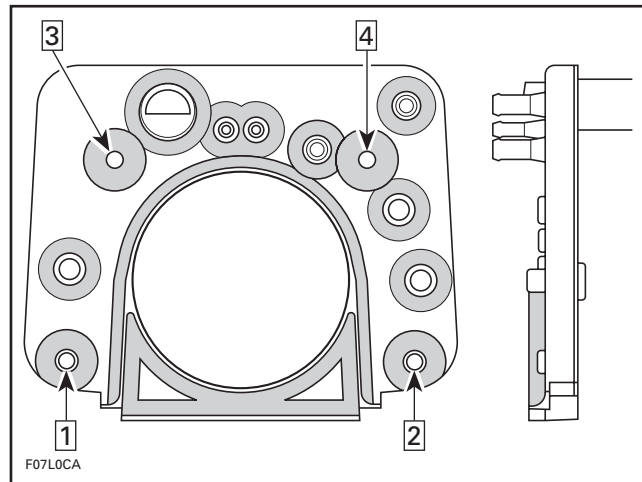

GS, GSI, GSX, GTI AND GTX MODELS

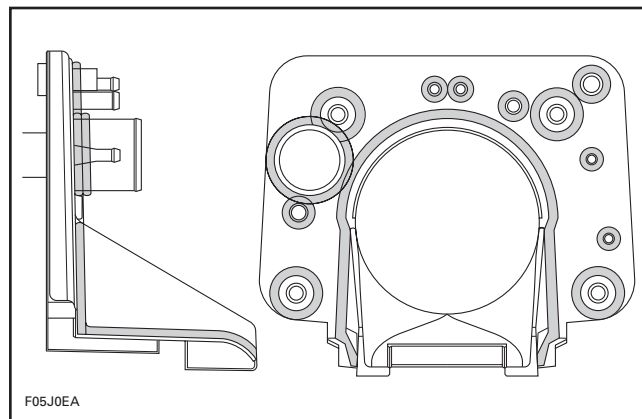

HX MODEL

DEFLECTOR

GS, GSI, GSX, GTI and GTX Models

Removal

Using a heat gun, heat deflector and pry it using a piece of wood.

Installation

Apply Loctite 598 Ultra Black as indicated by the shaded area in the following illustration.

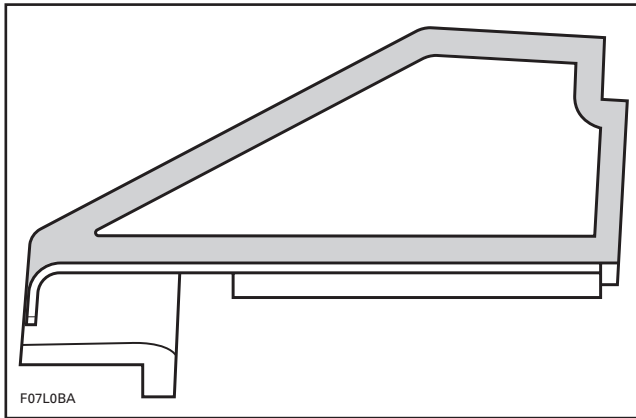

SEAT REMOVAL

HX Model Only

Remove seat bottom cover no. 17 and grab handle no. 18.

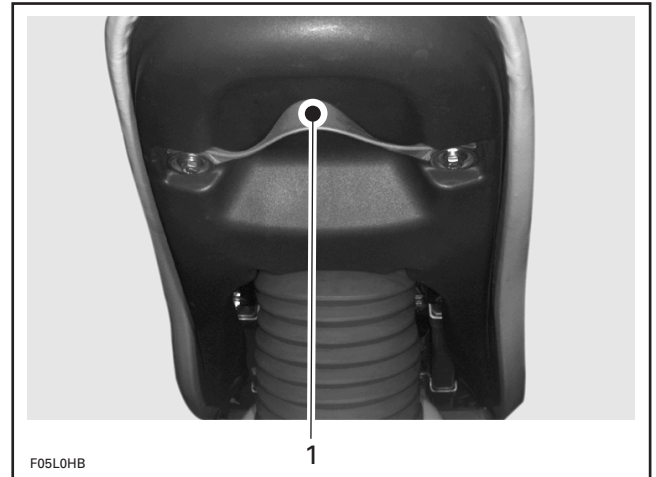

1. Handle
2. Cover

Loosen collar of coil over shock outer boot; then, pull outer boot downward.

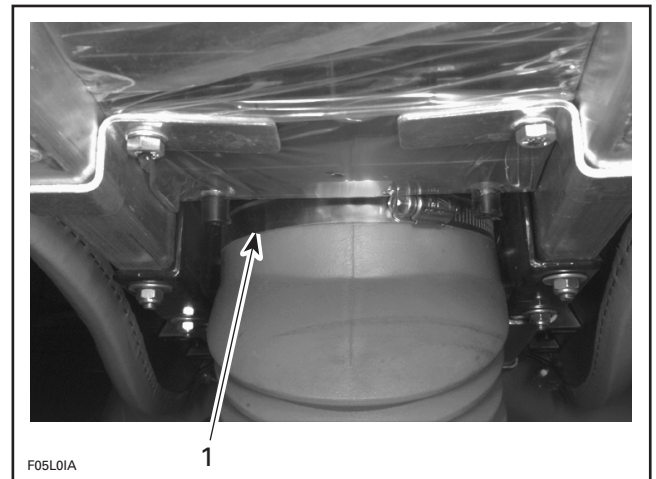

1. Collar

DRAIN PLUG INSTALLATION

Refer to the following illustration to install drain plug no. 15.

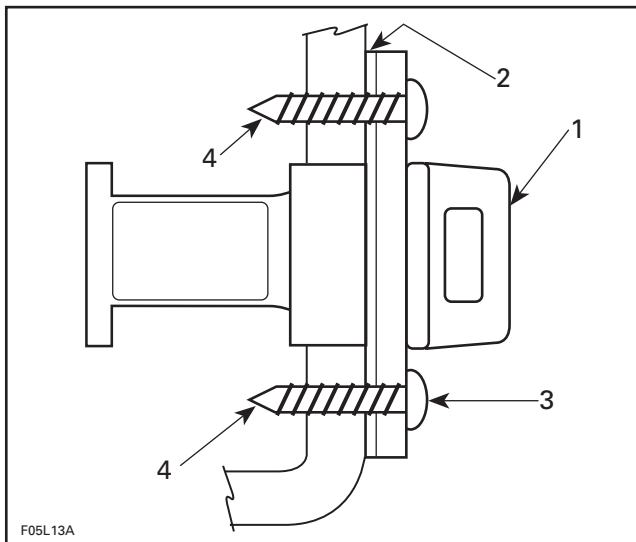

1. Drain plug
2. Gasket and 732 sealant
3. Torque screws to 1.5 N•m (13 lbf•in)
4. From inside bilge, apply 732 sealant on screws

Section 11 HULL/BODY

Sub-Section 02 (ADJUSTMENT AND REPAIR)

Loosen upper collar of coil over shock inner boot; then, pull boot downward.

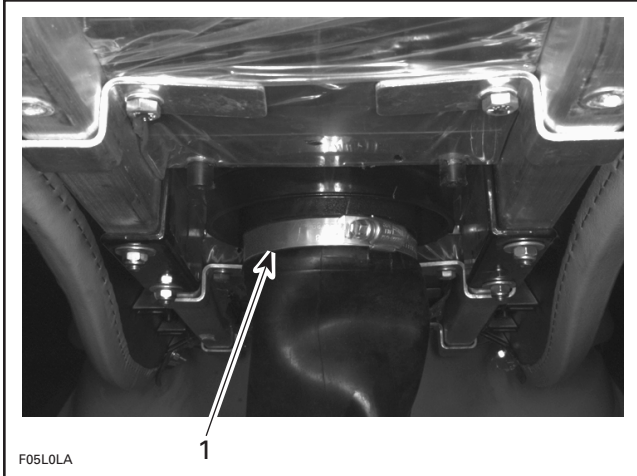

1. Collar

Remove bolt and lock nut from shock absorber upper support.

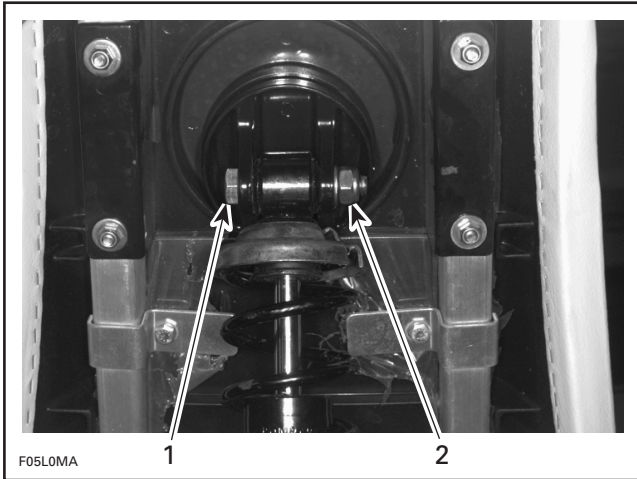

1. Bolt
2. Lock nut

Tilt seat.

Loosen side screws no. 19 retaining seat frame to pivot blocks no. 21.

Lower seat.

Loosen upper screws no. 20 retaining seat frame to pivot blocks no. 21.

Remove seat.

Seat installation is essentially the reverse of removal procedure. Refer to the main illustration of seat at the beginning of this sub-section for proper torque specifications and service products to be used.

SEAT COVER REPLACEMENT

Install staples with an electric tacker such as Arrow tacker no. ETN-50 or with a manual tacker such as Arrow tacker no. T-50.

NOTE: For an easier installation, it's highly recommended to use an electric tacker.

Ensure that the seat rest firmly against a hard surface such as a piece of wood. This is done to get the staples completely pushed in place.

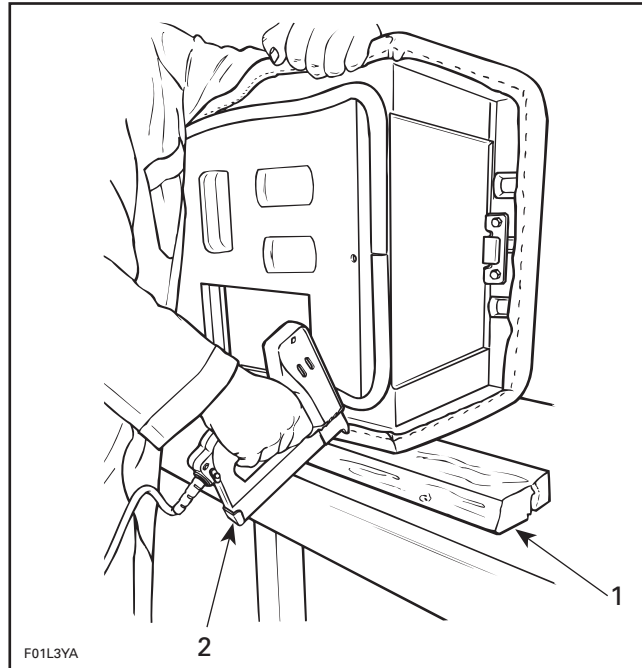

TYPICAL

1. Piece of wood
2. ETN-50 (electric) or T-50 (manual)

After cover installation cut all around the excess of material.

BUMPER REPLACEMENT

1. Remove trim **no. 5** from side bumper rail **no. 4**.
2. Drill pop rivets **no. 12** to remove side bumper rail **no. 4**.
3. Mark hole positions on body straight and bow sections.

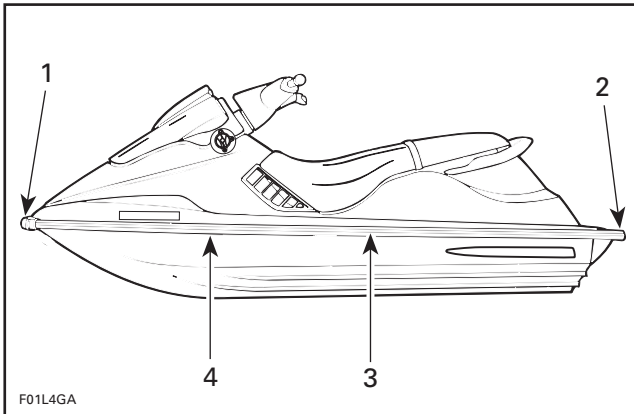

TYPICAL

1. Front bumper
2. Corner bumper
3. Straight section
4. Bow section

4. Slide bumper rail **no. 4** under front bumper **no. 13**.
5. Using a 4.80 mm (3/16 in) drill bit, drill first hole through bumper rail **no. 4** at front of bow section. Use locating mark as a guide. Then install a rivet **no. 12**.

▼ CAUTION

When drilling, be careful not to damage bumper rail and/or hull.

6. Position bumper rail **no. 4** properly onto body and cut excess length if necessary.
7. Slide bumper rail **no. 4** in corner bumper **no. 14**.
8. Using hole positions previously marked on body, drill holes in bumper rail **no. 4** and install rivets **no. 12**.
9. Install trim **no. 5** using soapy water.
10. Repeat procedure for the other side.

SPONSON REPLACEMENT

Remove seat (access cover for the XP model).
Remove air vent tube support (SP, SPX, GS, GSI and GSX models).

Remove muffler.

From bilge, unscrew sponsons **no. 6** using a 10 mm deep socket with an extension.

Remove sponsons **no. 6**. Clean any residues of sealant adhesive on hull.

Install gaskets **no. 7** on new sponsons **no. 6**.

Apply sealant 732 (P/N 293 800 006) or sealant adhesive (P/N 293 800 033) around sponson studs.

Apply Loctite 242 (blue) on sponson studs.

Install sponsons **no. 6** on hull.

From bilge, first insert flat washers **no. 8** over sponson studs, then lock washers **no. 9**. Secure with lock nuts **no. 10**. Tighten to 5 N•m (44 lbf•in).

NOTE: To ease flat washer and lock washer installation, use a flexible 4-claw Snap-on pick-up tool.

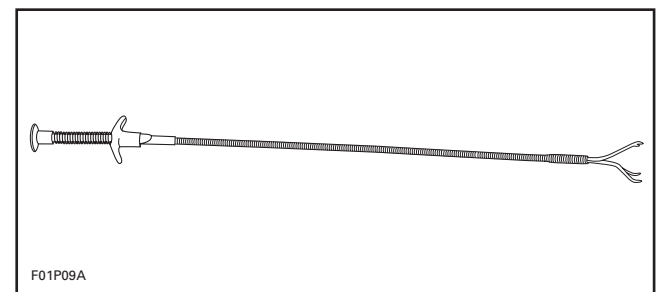

Reinstall muffler. Tighten hose clamps to 4 N•m (35 lbf•in).

Reinstall air vent tube support (SP, SPX, GS, GSI and GSX models).

Reinstall seat.

Clean hull and sponsons of any sealant adhesive surplus.

◆ WARNING

Recommended torques and use of Loctite must be strictly followed.

Section 11 HULL/BODY

Sub-Section 02 (ADJUSTMENT AND REPAIR)

BAFFLE SEALING (GTS MODEL)

Apply Sikaflex primer 449 (P/N 293 530 012) on rear baffle no. 11 and body sections to be sealed.



CAUTION

Allow at least 30 minutes for primer to cure.

Apply Sikaflex sealant 221 (P/N 293 530 011) on rear baffle section to be sealed.

Before using the watercraft wait 3 days for Sikaflex curing time.

HOOD REMOVAL

HX and XP Models

Disconnect throttle and choke cables at carburetor linkage.

Disconnect wiring harnesses of start/stop button, monitoring beeper, safety lanyard switch and gauge(s).

Loosen bolts and nuts of hinge from watercraft body.

Disconnect the gas assist cylinder (XP model).

Remove hood.

Hood installation is essentially the reverse of removal procedure. Refer to the main illustration of hood at the beginning of this sub-section for proper torque specifications and service products to be used.

DECALS REPLACEMENT

Removal

Using a heat gun warm up one end of decal for a few seconds until decal can roll off when rubbing with your finger.

Pull decal slowly and when necessary apply more heat to ease removal on the area that has to be peeled off.

If decal tears while pulling off, it has to be heated for a few seconds longer. If decal tends to stretch while pulling off, stop heating and wait a few seconds to let it cool, then peel it off.

Installation

There are 2 types of decals used on watercraft. One has a protective film on back side and the other has a protective film on both sides. They are used on 3 types of materials; plastic, gelcoat and metal.

DECALS HAVING A PROTECTIVE FILM ON BACK SIDE ONLY

These decals usually contain written information (ex.: warning) and are used on gelcoat or metal.

Clean surface with a good solvent such as ACRYLICLEAN DX 330 from PPG or equivalent (refer to manufacturer instructions).

Using a pencil and the decal as a template, mark the area where decal will be located.

Remove half of the decal back protective film and align decal with marks. Start sticking it from center and remove the other half of the film to stick it completely. Carefully squeegee decal beginning at center and working outward using, firm, short, overlapping strokes.

DECALS HAVING A PROTECTIVE FILM ON BOTH SIDES

These decals usually contain graphics and are used on gelcoat or plastic.

INSTALLATION ON GELCOAT

Clean surface with a good solvent such as ACRYLICLEAN DX 330 from PPG or equivalent (refer to manufacturer instructions).

For best result apply an activator (P/N 293 530 036) to prepare the surface using a clean cloth. After a few seconds, when the activator evaporates, the surface is ready.

Using a pencil and the decal as a template mark the area where decal will be located.

For better adhesion a dry application is recommended, however, to ease decal installation a mild solution of soapy water can be sprayed over surface where decal will be installed.

Remove back protective film from decal and align decal with marks. When well aligned squeegee decal beginning at center and working outward using firm, short, overlapping strokes.

Remove front protective film once decal has adhered to hull.

INSTALLATION ON PLASTIC (STORAGE COVER)

Clean surface with isopropyl alcohol.

Using a pencil and the decal as a template, mark the area where decal will be located.

Apply an activator (P/N 293 530 036) to prepare the surface using a clean cloth. After a few seconds, when the activator evaporates, the surface is ready.

 CAUTION

Do not use soapy water to locate decal on plastic parts.

Remove back protective film from decal and carefully align decal with marks. When well aligned squeegee decal beginning at center and working outward using firm, short, overlapping strokes.

Remove front protective film once decal has adhered.

HULL AND BODY REPAIR

General

Gelcoat is the smooth and durable cosmetic finish which coats the fiberglass hull and body of a Sea-Doo watercraft. It also provides a protective barrier against water and sun. It consists of a mixture of resin, pigment (coloring), fillers, monomers and catalyst which is sprayed into the mold.

The body and hull of the Sea-Doo are constructed of chopped fiberglass, saturated with resin. It is sprayed on the layer of gelcoat along with pieces of fiberglass mat, cloth and woven rowing which are added at required areas. This type of construction is very accommodating for high quality repairs. With patience, the proper techniques and materials, a damaged area can be restored to an original finish.

NOTE: Fiberglass repair kit is available through automotive or marine suppliers. Gelcoat repair kits are available through regular channel.

 WARNING

<p>Protect skin, wear gloves when in contact with resin, hardeners and gelcoat. A barrier skin cream may also be used. Do not expose area to open flame or lit cigarette. Some of the materials are flammable. Protect eyes, wear safety glasses when grinding, sanding or spraying. Use a dust mask when sanding or grinding. When spraying wear a respirator or paint mask. Always read warning labels on products.</p>

Air Bubbles

Possible Cause:

- Air pocket trapped between layers of laminate and gelcoat.

PREPARATION OF SURFACE

Remove all of the damaged gelcoat surrounding the air bubble with a putty knife or preferably a carbide grinding tip. Make sure all loose and weak areas are completely removed. Sand a small area of the gelcoat surface with 220-grit sandpaper. If needed, sand the cavity itself. These areas must have a rough surface to allow the gelcoat putty to bond properly.

FILLING THE CAVITY

The prepared surface must be cleaned with acetone on a cloth. Use the Bombardier gelcoat repair kit (P/N 295 500 100). Follow the mixing instructions in the kit when preparing the gelcoat putty.

Carefully mix the required amount while making sure there are no air bubbles in the mixture. With a putty knife, fill the repair area and cover with plastic film. Curing time may depend on temperature, amount of putty and percentage of catalyst. After 2 hours, press lightly on the surface with fingers to test the hardness. When the area becomes hard, remove the plastic film.

Section 11 HULL/BODY

Sub-Section 02 (ADJUSTMENT AND REPAIR)

SANDING

Begin block sanding the patch with 320-grit sandpaper until you come close to the original surface. Remove dust with a water soaked cloth and continue sanding with a 400-grit wet paper. Finish wet sanding with a 600-grit to remove deeper scratches. If needed you can wet sand with finer grit paper such as 1000-grit.

BUFFING AND WAXING

Buff the surface using a heavy duty polisher with a buffing pad. Make sure the pad is free of dirt or you may damage the gelcoat. Carefully begin buffing with a white medium compound. Finish off using a fine compound. While buffing, pay close attention to avoid overheating the surface.

Blisters

Possible Causes:

- Insert catalyst.
- Improper catalyst/gelcoat ratio.

A blister is a visible bump on the watercraft surface that may not necessarily come right through the gelcoat layer. In the case of only a few blisters, follow the same repair procedure as for air bubbles. If they are numerous and in close concentration, spray liquid gelcoat to achieve proper repair. This procedure is covered in **Minor Gelcoat Fractures**.

Minor Gelcoat Fractures

Possible Causes:

- Flexing of fiberglass laminate.
- Gelcoat thickness.
- Direct result of impact.

In case of fractures which have not penetrated past the gelcoat layer, the repair concerns the gelcoat only. If flex cracking or impact are evident, then additional reinforcement may be necessary. This subject will be covered in **Compound Fractures**.

PREPARING THE SURFACES

Small Fractures

Open the cracks up with a sharp triangular can opener or preferably a carbide tipped die grinder. The V groove will provide a good bonding area for the gelcoat. With 220-grit sandpaper, sand the sides of the notched out areas.

Numerous Fractures

Using a grinder with a 24-grit disk, remove the gelcoat. Sand the area edge with 220-grit sandpaper.

FILLING THE REPAIR AREA

Small Fractures

Refer to the same procedure as in the **Air Bubbles**.

Numerous Fractures Over Large Surface:

Prepare the area for spray application of liquid gelcoat. Wipe down the surface with acetone. Mask the area off to protect the watercraft from overspray.

Mix the needed quantity of gelcoat and catalyst according to suppliers recommendations. The gelcoat can be thinned with acetone up to 10%. If it needs more consistency you can add cabosil.

Make sure that the air supply is free of oil, dirt and water.

Test spray the gelcoat mixture on paper to verify its consistency and pattern. You may have to apply 5 or 6 coats to cover the area properly. Overlap each coat further than the last, leaving at least 30 seconds between passes. Avoid trying to coat the surface with only a few heavy coats, this will not allow the gelcoat to dry properly.

Apply a coat of polyvinyl alcohol to seal off the air and protect the gelcoat surface from dust. PVA speeds up the curing process because gelcoat will not cure properly when exposed to air.

SANDING

Wash the polyvinyl alcohol off with water. Depending on the size of the area repaired, you can either block sand as per previous procedure or you may use an air sander. Sand the surface down with progressively finer grits of sandpaper until the desired finish is achieved.

BUFFING AND WAXING

Buff the surface using a heavy duty polisher with a buffing pad. Make sure the pad is free of dirt or you may damage the gelcoat. Carefully begin buffing with a white medium compound. Finish off using a fine compound. While buffing, pay close attention to avoid overheating the surface.

Compound Fractures

Possible Causes:

- Thickness of fiberglass laminate.
- Direct result of impact.

Compound fractures are those that have gone past the gelcoated surface and in through the layers of fiberglass laminate. Two types of repairs have to be performed. The first is to restore the structural integrity of the damaged area. Fracture types can vary from a simple crack to a large hole. Usually, fiberglass reinforcement becomes necessary, especially if the fracture can be attributed to weakness. The final part of the repair is the gelcoating, which cannot be done until the interior and exterior laminate surfaces have been repaired.

Outside

Remove the damaged gelcoat and fiberglass with a 24-grit disk using a power sander. Grind outward at least 2 inches from the fracture to allow the patch to bond to strong material. Cut enough pieces of fiberglass mat necessary to build up the area. The pieces should be cut so they overlap each other by at least a half inch. For a smoother finish, the last layer should be fiberglass cloth. If the fracture is small enough all you may have to do is fill the area with an epoxy filler.

Inside

For the interior repair, you can grind more. This will allow for more fiberglass material which will strengthen the area. If the fracture opening is too large after surface preparation, you may need a backing support to cover the opening. Cut alternating pieces of fiberglass mat and cloth in overlapping sizes.

PATCHING THE REPAIR AREA

Outside

The outside should be done first. Wipe clean the area with acetone on a cloth, then mask off area. For a small crack use an epoxy filler in the same way you would use Bombardier's gelcoat repair putty. When laying up a larger area you will use mat, cloth and fiberglass resin and hardener. Use a clean container to mix the resin, mix only what you will need. Follow the recommended catalyst ratio.

Using a clean paintbrush, brush the mixed resin on the surface. Place the smallest piece of mat over the fracture and then wet out the mat. Follow with the remaining pieces of mat and final layer of cloth. While wetting the pieces make sure you work the air bubbles out and saturate all the pieces evenly. Try to work quickly, you may only have 15 or 20 minutes. You may clean the brush with acetone.

Wait until the repair has hardened before moving on to the interior repair. If the size of the opening is too large for the pieces to maintain the proper shape, you will have to use a backing support. It is a shaped piece of cardboard that fits flush to the interior surface and has a plastic layer on the repair side. It is held in place by tape or a support.

Inside

Wipe down the area with acetone on a cloth. Apply the same procedure as for outside repair when laminating the alternating pieces of fiberglass material. If a backing support was used, remove it before starting the repair. After the area has hardened, remove sharp edges of material from surface. If required paint the surface.

SANDING

Outside

This surface will have to be prepared for application of gelcoat. The size of the area will determine the gelcoating procedure to be used. Refer to the repair procedure for minor gelcoat fractures.

BUFFING AND WAXING

Refer to the buffing and waxing for **Minor Gelcoat Fractures**.

TOOLS AND MATERIALS LIST

Tools

- safety glasses
- air mask
- white cloths
- sanding block
- putty knife
- plastic film
- stirring stick
- cover sheets (for Sea-Doo)
- scissors
- buffing pad

Section 11 HULL/BODY

Sub-Section 02 (ADJUSTMENT AND REPAIR)

- heavy-duty polisher
- power sander
- paint brush
- plastic container (mixing)
- spray gun
- plastic squeegee

Materials

- fiberglass mat
- fiberglass cloth
- polyester resin
- cardboard
- masking tape
- sandpaper
(100-grit, 220-grit, 320-grit, 400-grit, 600-grit, 1000-grit)
- 24-grit sanding disks
- Bombardier gelcoat putty
- Bombardier liquid gelcoat
- acetone
- cabosil
- epoxy filler
- medium compound (white)
- fine compound (white)
- wax

HULL INSERT REPAIR

For hull insert repair proceed as follows:

Cut plastic hull insert flush with hull using a saw.

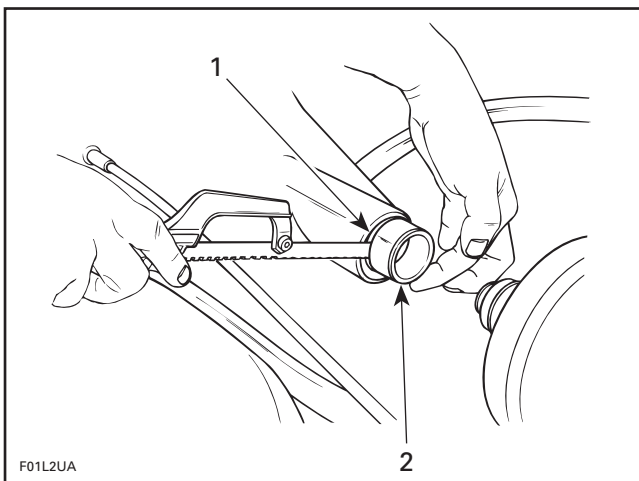

1. Hull
2. Plastic hull insert

Mix epoxy glue (3M-05900), follow manufacturer instructions.

Apply epoxy glue on aluminum insert (P/N 292 000 075) knurled surface and on plastic insert inner bore.

▼ CAUTION

If you notice any clearance between plastic insert and aluminum insert, fill gap with epoxy glue to obtain good adhesion of aluminum insert.

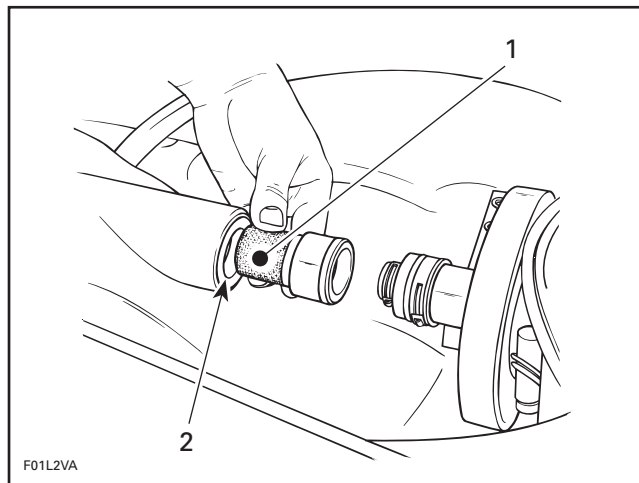

1. Knurled surface
2. Inner bore

Install aluminum insert into plastic hull insert.

NOTE: Align aluminum insert as much as possible with PTO flywheel.

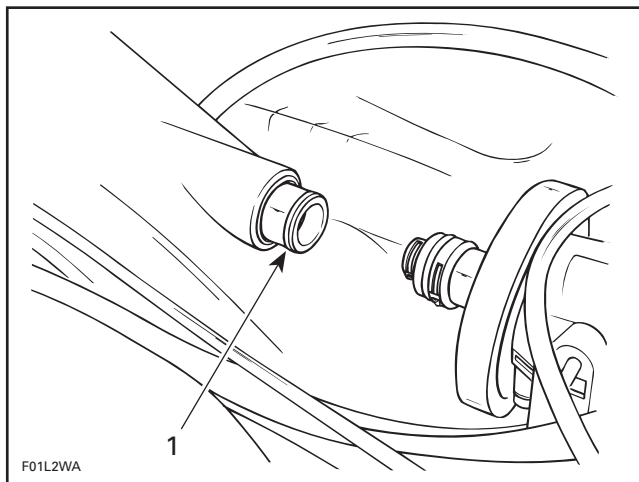

1. Aluminum insert

NOTE: The epoxy glue curing time is 30 minutes.

Section 12 TECHNICAL DATA
Sub-Section 01 (SP AND SPX MODELS)

SP AND SPX MODELS

ENGINE		SP (5879)	SPX (5834/5661)
Engine type		Bombardier-Rotax 717D	Bombardier-Rotax 787
Induction type		Rotary valve	
Exhaust system	Type	Water cooled, water injected	Water cooled, water injected with regulator
	Water injection fitting (head)	4.5 mm (.177 in)	3.5 mm (.139 in)
	Water injection fitting (cone)	Not applicable	
	Water injection fitting (muffler)	Not applicable	3.5 mm (.139 in)
Exhaust valve		Not applicable	Rotax Adjustable Variable Exhaust (RAVE)
Starting system		Electric start	
Lubrication	Fuel/oil mixture	VROI (Variable Rate Oil Injection)	
	Oil injection pump	Gear driven	Direct driven
	Oil type	BOMBARDIER-ROTAX injection oil	
Number of cylinders		2	
Bore	Standard	82 mm (3.228 in)	
	First oversize	82.25 mm (3.238 in)	
	Second oversize	82.50 mm (3.248 in)	Not applicable
Stroke		68 mm (2.68 in)	74 mm (2.99 in)
Displacement		718.2 cm ³ (43.81 in ³)	781.6 cm ³ (47.7 in ³)
Corrected compression ratio		6.5: 1	6.0: 1
Cylinder head warpage (maximum)		0.05 mm (.002 in)	
Piston ring type and quantity		1 Semi-trapez – 1 Rectangular	
Ring end gap	New	0.25 - 0.40 mm (.010 - .016 in)	
	Wear limit	1.00 mm (.039 in)	
Ring/piston groove clearance	New	0.025 - 0.070 mm (.001 - .003 in)	
	Wear limit	0.2 mm (.008 in)	
Piston/cylinder wall clearance	New (minimum)	0.100 mm (.0039 in)	0.110 mm (.0043 in)
	Wear limit	0.200 mm (.008 in)	
Cylinder taper (maximum)		0.100 mm (.004 in)	
Cylinder out of round (maximum)		0.080 mm (.003 in)	
Connecting rod big end axial play	New	0.311 - 0.678 mm (.012 - .027 in)	0.230 - 0.617 (.009 - .024 in)
	Wear limit	1.2 mm (.047 in)	
Crankshaft deflection		MAG side: 0.050 mm (.002 in) PTO side: 0.030 mm (.001 in)	
Rotary valve timing	Opening	134° ± 5 BTDC	146.5° ± 5 BTDC
	Closing	51.5° ± 5 ATDC	64° ± 5 ATDC
Rotary valve duration		132°	159°
Crankcase/rotary valve gap		0.25 - 0.35 mm (.010 - .014 in)	
Connecting rod/crankshaft pin radial clearance	New	0.020 - 0.033 mm (.0008 - .0013 in)	0.023 - 0.034 mm (.0009 - .0013 in)
	Wear limit	0.050 mm (.002 in)	
Connecting rod/piston pin radial clearance	New	0.003 - 0.012 mm (.00012 - .00047 in)	
	Wear limit	0.015 mm (.00059 in)	
ADDITIONAL INFORMATION:			

Section 12 TECHNICAL DATA

Sub-Section 01 (SP AND SPX MODELS)

ELECTRICAL		SP (5879)	SPX (5834/5661)
Magneto generator output		160 W @ 6000 RPM or 4.0 A @ 2000 RPM	180 W @ 6000 RPM or 5.0 A @ 6000 RPM
Ignition system type		Digital CDI	Digital DC-CDI
Spark plug	Make and type	NGK BR7ES	NGK BR8ES
	Gap	0.5 - 0.6 mm (.020 - .024 in)	
Ignition timing (BTDC)	mm (in)	2.59 (.102)	3.38 (.133)
	Degrees	20° ± 1 ①	22° ± 1 @ 3500 RPM
Generating coil		40 - 76 Ω	Not applicable
Battery charging coil		0.05 - 0.6 Ω	0.1 - 1 Ω
Trigger coil		Not applicable	190 - 300 Ω
Ignition coil	Primary	Not applicable	0.33 - 0.62 Ω
	Secondary	9 - 15 kΩ	8.4 - 15.6 kΩ
Engine rev limiter setting		5900 (± 50) RPM	7200 (± 50) RPM
Battery		(Yuasa/Exide) 12 V, 19 A•h	
Fuse	Starting system	5 A	
	Charging system	15 A	2 x 15 A
	VTS system	Not applicable	7.5 A
ADDITIONAL INFORMATION: ① Engine cold @ 5500 RPM.			
CARBURETION		SP (5879)	SPX (5834/5661)
Carburetor	Type	Mikuni BN-38 (diaphragm)	Mikuni BN-40I (diaphragm)
	Quantity	1	2
Main jet		135	142.5
Pilot jet		57.5	70
Spring		115 g	80 g
Adjustment	Low-speed screw	1-3/4 turn ± 1/4	1 turn ± 1/4
	High-speed screw	0	
	Idle speed (in water)	1500 RPM	
	Idle speed (out of water)	3000 RPM	
Fuel	Type	Regular unleaded gasoline	
	Minimum octane no.	87	
Fuel return line orifice		0.8 mm (.031 in)	MAG and PTO: 0.8 mm (.031 in)
ADDITIONAL INFORMATION:			
COOLING		SP (5879)	SPX (5834/5661)
Type		Open circuit – Direct flow from jet propulsion unit	
Thermostat		None	
Monitoring beeper setting		95-103°C (203-217°F)	
ADDITIONAL INFORMATION:			

Section 12 TECHNICAL DATA
Sub-Section 01 (SP AND SPX MODELS)

PROPULSION		SP (5879)	SPX (5834/5661)
Propulsion system		Bombardier Formula Pump	
Jet pump type		Axial flow single stage	
Impeller rotation (seen from rear)		Counterclockwise	
Transmission		Direct drive	
Coupling type		Crown splines	
Oil type		SEA-DOO JET PUMP SYNTHETIC POLYOLESTER OIL 75W90 GL5	
Steering nozzle pivoting angle		26°	
Minimum required water level		90 cm (35 in)	
Drive shaft deflection (maximum)		0.5 mm (.020 in)	
Impeller outside diameter		139.5 mm (5.490 in)	
Impeller/wear ring clearance	New	0.0 - 0.4 mm (.000 - .016 in)	
	Wear limit	1.0 mm (.040 in)	
Impeller shaft end play (new)		0.12 - 0.54 mm (.005 - .021 in)	
Impeller shaft side play		0.05 mm (.002 in)	
Impeller pitch/material		Progressive pitch 16° - 35°/aluminum	Progressive pitch 16° - 23°/stainless steel
ADDITIONAL INFORMATION: Do not mix different brands or oil types.			
DIMENSIONS		SP (5879)	SPX (5834/5661)
Number of passenger (driver incl.)		2	
Overall length		254 cm (100 in)	
Overall width		105 cm (41.3 in)	
Overall height		92 cm (36.2 in)	
Dry weight		187 kg (412 lb)	197 kg (434 lb)
Load limit (passenger and 10 kg (22 lb) luggage)		160 kg (352 lb)	
ADDITIONAL INFORMATION:			
CAPACITIES		SP (5879)	SPX (5834/5661)
Fuel tank		34 L (9 U.S. gal)	
Impeller shaft reservoir	Capacity	70 mL (2.4 U.S. oz)	
	Oil level height	Up to plug	
Oil injection reservoir		4.5 L (1.2 U.S. gal)	
ADDITIONAL INFORMATION:			

Section 12 TECHNICAL DATA

Sub-Section 01 (SP AND SPX MODELS)

MATERIALS		SP (5879)	SPX (5834/5661)
Hull		Composite	
Inlet grate		Plastic	
Impeller housing/stator/venturi/nozzle		Plastic/plastic/ plastic/plastic	Plastic/brass/plastic/ aluminum
Air intake silencer		Thermoplastic	
Flame arrester		Multi-layer wire screen	
Exhaust muffler		Aluminum	
Steering padding		Thermoplastic elastomer with polystyrene foam	
Fuel tank		Polyethylene	
Oil injection reservoir		Polyethylene	
Seat		Polyurethane foam	
ADDITIONAL INFORMATION:			
STANDARD EQUIPMENT		SP (5879)	SPX (5834/5661)
Safety lanyard		Standard	
Digitally Encoded Security System		Standard	
Tool kit		Standard	
Fuel tank reserve		Standard	
Monitoring beeper		Standard	
Speedometer		Optional	
Fuel/oil gauge (analog)		Optional	Standard
Tachometer		Optional	
Variable trim system (VTS)		Optional (manual)	Standard
Reverse		Not applicable	
Storage compartment		Standard	
Rear grab handle		Optional	Standard
Extinguisher holder		Standard	
ADDITIONAL INFORMATION:			
PERFORMANCE		SP (5879)	SPX (5834/5661)
Estimated pump power		42 kW (57 hp)	
Maximum fuel consumption at wide open throttle		23.5 L/h (6.2 U.S. gal/h)	44.5 L/h (11.7 U.S. gal/h)
Cruising time at full throttle	Fuel tank without reserve	1 hour 14 minutes	39 minutes
	Fuel tank reserve	13 minutes	7 minutes
ADDITIONAL INFORMATION:			

Section 12 TECHNICAL DATA
Sub-Section 01 (SP AND SPX MODELS)

TIGHTENING TORQUES		SP (5879)	SPX (5834/5661)	
ENGINE	Exhaust manifold screw	24 N•m (17 lbf•ft) (4)	40 N•m (30lbf•ft) (3) (4)	
	Magneto flywheel nut	145 N•m (107 lbf•ft) (1)	105 N•m (77 lbf•ft) (1)	
	Flywheel (PTO side)	110 N•m	(81 lbf•ft) (5)	
	Crankcase screws	M8	24 N•m	(17 lbf•ft) (3) (4)
		M10	40 N•m	(30 lbf•ft) (3) (4)
	Crankcase/engine support nuts	35 N•m	(26 lbf•ft) (1)	
	Engine mount/hull	25 N•m	(18 lbf•ft) (1)	
	Cylinder head screws	24 N•m	(17 lbf•ft) (1) (4)	
	Crankcase/cylinder screws	24 N•m (17 lbf•ft) (1) (4)	40 N•m (30 lbf•ft) (3) (4)	
	Tuned pipe flange screws/nut	25 N•m (18 lbf•ft) (1)	40 N•m (30 lbf•ft) (1)	
	Tuned pipe fixation screws	25 N•m	(18 lbf•ft) (1)	
	Flame arrester screws	10 N•m	(88 lbf•in) (1)	
	Magneto housing cover screws	9 N•m	(80 lbf•in) (5)	
	Starter mounting screws	22 N•m	(16 lbf•ft) (1)	
	Starter lock nuts	7 N•m	(62 lbf•in)	
Spark plugs	24 N•m	(17 lbf•ft) (5)		
JET PUMP	Impeller	70 N•m	(52 lbf•ft) (2)	
	Pump/hull nuts	33 N•m	(24 lbf•ft) (1)	
	Venturi/pump housing screws	21 N•m	(16 lbf•ft) (1)	
	VTS ring screws	Not applicable	14 N•m (10 lbf•ft) (1)	
	Pump housing cover screws	4 N•m	(35 lbf•in) (1)	
	Inlet grate screws	8 N•m	(71 lbf•in) (1)	
	Riding plate screws	10 N•m	(88 lbf•in) (1)	
STEERING	Cable retaining block bolts	6 N•m	(53 lbf•in)	
	Steering cable/stem arm bolt	3 N•m	(26 lbf•in)	
	Steering stem arm bolts	6 N•m	(53 lbf•in)	
	Handlebar clamp bolts	26 N•m	(19 lbf•ft)	
	Steering cable ball joint (nozzle)	2 N•m (18 lbf•in)	7 N•m (62 lbf•in)	
	Front support bolts	15 N•m	(11 lbf•ft)	
	Rear support/cable bracket bolts	15 N•m	(11 lbf•ft)	
ADDITIONAL INFORMATION: apply where indicated; (1) Loctite 242 (blue) (2) Loctite 271 (red) (3) Loctite 515 (4) Synthetic grease (5) Anti-seize lubricant <div style="text-align: center;">  WARNING: Correct torques and use of Loctite must be strictly followed. </div>				

GS AND GSI MODELS

ENGINE		GS (5621)	GSI (5622)
Engine type		Bombardier-Rotax 717	
Induction type		Rotary valve	
Exhaust system	Type	Water cooled, water injected	
	Water injection fitting (head)	3.5 mm (.139 in)	
	Water injection fitting (cone)	3.5 mm (.139 in)	
Starting system		Electric start	
Lubrication	Fuel/oil mixture	VROI (Variable Rate Oil Injection)	
	Oil injection pump	Gear driven	
	Oil type	BOMBARDIER-ROTAX injection oil	
Number of cylinders		2	
Bore	Standard	82 mm (3.228 in)	
	First oversize	82.25 mm (3.238 in)	
	Second oversize	82.50 mm (3.248 in)	
Stroke		68 mm (2.677 in)	
Displacement		718.2 cm ³ (43.81 in ³)	
Corrected compression ratio		6.2: 1	
Cylinder head warpage (maximum)		0.05 mm (.002 in)	
Piston ring type and quantity		1 Semi-trapez – 1 Rectangular	
Ring end gap	New	0.25 - 0.40 mm (.010 - .016 in)	
	Wear limit	1.00 mm (.039 in)	
Ring/piston groove clearance	New	0.025 - 0.070 mm (.001 - .003 in)	
	Wear limit	0.2 mm (.008 in)	
Piston/cylinder wall clearance	New (minimum)	0.100 mm (.0039 in)	
	Wear limit	0.2 mm (.008 in)	
Cylinder taper (maximum)		0.100 mm (.004 in)	
Cylinder out of round (maximum)		0.080 mm (.003 in)	
Connecting rod big end axial play	New	0.311 - 0.678 mm (.012 - .027 in)	
	Wear limit	1.2 mm (.047 in)	
Crankshaft deflection		MAG side: 0.050 mm (.002 in) PTO side: 0.030 mm (.001 in)	
Rotary valve timing	Opening	147° ± 5 BTDC	
	Closing	65.5° ± 5 ATDC	
Rotary valve duration		159°	
Crankcase/rotary valve gap		0.25 - 0.35 mm (.010 - .014 in)	
Connecting rod/crankshaft pin radial clearance	New	0.020 - 0.033 mm (.0008 - .0013 in)	
	Wear limit	0.050 mm (.002 in)	
Connecting rod/piston pin radial clearance	New	0.003 - 0.012 mm (.00012 - .00047 in)	
	Wear limit	0.015 mm (.00059 in)	
ADDITIONAL INFORMATION:			

Section 12 TECHNICAL DATA

Sub-Section 02 (GS AND GSI MODELS)

ELECTRICAL		GS (5621)	GSI (5622)
Magneto generator output		160 W @ 6000 RPM or 4.0 A @ 2000 RPM	
Ignition system type		Digital CDI	
Spark plug	Make and type	NGK BR8ES	
	Gap	0.5 - 0.6 mm (.020 - .024 in)	
Ignition timing (BTDC)	mm (in)	2.59 (.102)	
	Degrees	20° ± 1 ①	
Generating coil		40 - 76 Ω	
Battery charging coil		0.05 - 0.6 Ω	
Ignition coil	Primary	0.33 - 0.62 Ω	
	Secondary	8.4 - 15.6 kΩ	
Engine rev limiter setting		7000 ± 50 RPM	
Battery		(Yuasa/Exide) 12 V, 19 A•h	
Fuse	Starting system	5 A	
	Charging system	2 x 15 A	
ADDITIONAL INFORMATION: ① Engine cold @ 6000 RPM.			
CARBURETION		GS (5621)	GSI (5622)
Carburetor	Type	Mikuni BN-40I (diaphragm)	
	Quantity	1	
Main jet		175	
Pilot jet		70	
Spring		80 g	
Adjustment	Low-speed screw	1-3/4 turn ± 1/4	
	High-speed screw	0	
	Idle speed (in water)	1500 RPM	
	Idle speed (out of water)	3000 RPM	
Fuel	Type	Regular unleaded gasoline	
	Minimum octane no.	87	
Fuel return line orifice		0.8 mm (.031 in)	
ADDITIONAL INFORMATION:			
COOLING		GS (5621)	GSI (5622)
Type		Open circuit – Direct flow from jet propulsion unit	
Thermostat		None	
Monitoring beeper setting		86-94°C (187-201°F)	
ADDITIONAL INFORMATION:			

Section 12 TECHNICAL DATA
Sub-Section 02 (GS AND GSI MODELS)

PROPULSION		GS (5621)	GSI (5622)
Propulsion system		Bombardier Formula Pump	
Jet pump type		Axial flow single stage	
Impeller rotation (seen from rear)		Counterclockwise	
Transmission		Direct drive	
Coupling type		Crown splines	
Oil type		SEA-DOO JET PUMP SYNTHETIC POLYOLESTER OIL 75W90 GL5	
Steering nozzle pivoting angle		26°	
Minimum required water level		90 cm (35 in)	
Drive shaft deflection (maximum)		0.5 mm (.020 in)	
Impeller outside diameter		139.5 mm (5.490 in)	
Impeller/wear ring clearance	New	0.0 - 0.4 mm (.000 - .016 in)	
	Wear limit	1.0 mm (.040 in)	
Impeller shaft end play (new)		0.12 - 0.54 mm (.005 - .021 in)	
Impeller shaft side play		0.05 mm (.002 in)	
Impeller pitch/material		Progressive pitch 10° - 25°/aluminum	Progressive pitch 11° - 22°/stainless steel
ADDITIONAL INFORMATION: Do not mix different brands or oil types.			
DIMENSIONS		GS (5621)	GSI (5622)
Number of passenger (driver incl.)		2	
Overall length		267 cm (105 in)	
Overall width		116 cm (45.7 in)	
Overall height		94 cm (37 in)	
Dry weight		217 kg (478 lb)	
Load limit (passenger and 10 kg (22 lb) luggage)		165 kg (364 lb)	
ADDITIONAL INFORMATION:			
CAPACITIES		GS (5621)	GSI (5622)
Fuel tank		56.5 L (15 U.S. gal)	
Impeller shaft reservoir	Capacity	70 mL (2.4 U.S. oz)	
	Oil level height	To bottom of cover hole	
Oil injection reservoir		6 L (1.6 U.S. gal)	
ADDITIONAL INFORMATION:			

Section 12 TECHNICAL DATA

Sub-Section 02 (GS AND GSI MODELS)

MATERIALS	GS (5621)	GSI (5622)
Hull	Composite	
Inlet grate	Aluminum	
Impeller housing/stator/venturi/nozzle	Plastic/plastic/plastic/plastic	
Air intake silencer	Thermoplastic	
Flame arrester	Multi-layer wire screen	
Exhaust muffler	Aluminum	
Steering padding	Thermoplastic with Polyethylene foam	
Fuel tank	Polyethylene	
Oil injection reservoir	Polyethylene	
Seat	Polyurethane foam	
ADDITIONAL INFORMATION:		
STANDARD EQUIPMENT	GS (5621)	GSI (5622)
Safety lanyard	Standard	
Digitally Encoded Security System	Standard	
Fuel tank reserve	Standard	
Monitoring beeper	Standard	
Fuel/oil gauge (analog)	Standard	Not applicable
Info Center	Not applicable	Standard
Variable trim system	Optional	Standard
Storage compartment	Standard	
Rear grab handle	Standard	
Reverse	Not applicable	
Extinguisher holder	Standard	
Tool kit	Standard	
ADDITIONAL INFORMATION: Info Center standard functions: Fuel level/low fuel level/low oil level/low voltage/tachometer/high temperature/hour meter/clock/maintenance information/trim/chronometer		
PERFORMANCE	GS (5621)	GSI (5622)
Estimated pump power	34.9 kW (46.8 hp)	
Maximum fuel consumption at wide open throttle	33 L/h (8.7 U.S. gal/h)	
Cruising time at full throttle	Fuel tank without reserve	1 hour 21 minutes
	Fuel tank reserve	21 minutes
ADDITIONAL INFORMATION:		

Section 12 TECHNICAL DATA
Sub-Section 02 (GS AND GSI MODELS)

TIGHTENING TORQUES		GS (5621)	GSI (5622)	
ENGINE	Exhaust manifold screw	24 N•m	(17 lbf•ft) (4)	
	Magneto flywheel nut	145 N•m	(107 lbf•ft) (1)	
	Flywheel (PTO side)	110 N•m	(81 lbf•ft) (5)	
	Crankcase screws	M8	24 N•m	(17 lbf•ft) (3) (4)
		M10	40 N•m	(30 lbf•ft) (3) (4)
	Crankcase/engine support nuts	35 N•m	(26 lbf•ft) (1)	
	Engine mount/hull	25 N•m	(18 lbf•ft) (1)	
	Cylinder head screws	24 N•m	(17 lbf•ft) (1) (4)	
	Crankcase/cylinder screws	24 N•m	(17 lbf•ft) (1) (4)	
	Tuned pipe nut	25 N•m	(18 lbf•ft) (1)	
	Tuned pipe fixation screws	25 N•m	(18 lbf•ft) (1)	
	Flame arrester screws	10 N•m	(88 lbf•in) (1)	
	Magneto housing cover screws	9 N•m	(80 lbf•in) (5)	
	Starter mounting screws	22 N•m	(16 lbf•ft) (1)	
	Starter lock nuts	7 N•m	(62 lbf•in)	
Spark plugs	24 N•m	(17 lbf•ft) (5)		
JET PUMP	Impeller	70 N•m	(52 lbf•ft) (2)	
	Pump/hull nuts	31 N•m	(23 lbf•ft) (1)	
	Venturi/pump housing screws	21 N•m	(16 lbf•ft) (1)	
	VTS ring screws	Not applicable	14 N•m (10 lbf•ft) (1)	
	Pump housing cover screws	4 N•m	(35 lbf•in) (1)	
	Inlet grate screws	8 N•m	(71 lbf•in) (1)	
	Riding plate screws	22 N•m	(16 lbf•ft) (1)	
STEERING	Cable retaining block bolts	6 N•m	(53 lbf•in)	
	Steering cable/stem arm bolt	3 N•m	(26 lbf•in)	
	Steering stem arm bolts	6 N•m	(53 lbf•in)	
	Handlebar clamp bolts	26 N•m	(19 lbf•ft)	
	Steering cable ball joint (nozzle)	2 N•m	(18 lbf•in)	
	Steering support bolts	15 N•m	(11 lbf•ft) (1)	
	Handlebar grip screw	14 N•m	(10 lbf•ft)	
<p>ADDITIONAL INFORMATION: apply where indicated; (1) Loctite 242 (blue) (2) Loctite 271 (red) (3) Loctite 515 (4) Synthetic grease (5) Anti-seize lubricant</p> <p style="text-align: center;"> WARNING: Correct torques and use of Loctite must be strictly followed.</p>				

GSX MODEL

ENGINE		GSX (5624)
Engine type		Bombardier-Rotax 787
Induction type		Rotary valve
Exhaust system	Type	Water cooled, water injected with regulator
	Water injection fitting (head)	3.5 mm (.139 in)
	Water injection fitting (cone)	Not applicable
	Water injection fitting (muffler)	3.5 mm (.139 in)
Exhaust valve		Rotax Adjustable Variable Exhaust (RAVE)
Starting system		Electric start
Lubrication	Fuel/oil mixture	VROI (Variable Rate Oil Injection)
	Oil injection pump	Direct driven
	Oil type	BOMBARDIER-ROTAX injection oil
Number of cylinders		2
Bore	Standard	82 mm (3.228 in)
	First oversize	82.25 mm (3.238 in)
	Second oversize	Not applicable
Stroke		74 mm (2.99 in)
Displacement		781.6 cm ³ (47.7 in ³)
Corrected compression ratio		6.0: 1
Cylinder head warpage (maximum)		0.05 mm (.002 in)
Piston ring type and quantity		1 Semi-trapez – 1 Rectangular
Ring end gap	New	0.25 - 0.40 mm (.010 - .016 in)
	Wear limit	1.00 mm (.039 in)
Ring piston groove	New	0.025 - 0.070 mm (.001 - .003 in)
	Wear limit	0.2 mm (.008 in)
Piston/cylinder wall clearance	New (minimum)	0.110 mm (.0043 in)
	Wear limit	0.200 mm (.008 in)
Cylinder taper (maximum)		0.100 mm (.004 in)
Cylinder out of round (maximum)		0.080 mm (.003 in)
Connecting rod big end axial play	New	0.230 - 0.617 mm (.009 - .024 in)
	Wear limit	1.2 mm (.047 in)
Crankshaft deflection		MAG side: 0.050 mm (.002 in); PTO side: 0.030 mm (.001 in)
Rotary valve timing	Opening	146.5° ± 5 BTDC
	Closing	64° ± 5 ATDC
Rotary valve duration		159°
Crankcase/rotary valve gap		0.25 - 0.35 mm (.010 - .014 in)
Connecting rod/crankshaft pin radial clearance	New	0.023 - 0.034 mm (.0009 - .0013 in)
	Wear limit	0.050 mm (.002 in)
Connecting rod/piston pin radial clearance	New	0.003 - 0.012 mm (.00012 - .00047 in)
	Wear limit	0.015 mm (.00059 in)
ADDITIONAL INFORMATION:		

Section 12 TECHNICAL DATA

Sub-Section 03 (GSX MODEL)

ELECTRICAL		GSX (5624)
Magneto generator output		180 W @ 6000 RPM or 5.0 A @ 6000 RPM
Ignition system type		Digital DC-CDI
Spark plug	Make and type	NGK BR8ES
	Gap	0.5 - 0.6 mm (.020 - .024 in)
Ignition timing (BTDC)	mm (in)	3.38 (.133)
	Degrees	22° ± 1 @ 3500 RPM
Generating coil		Not applicable
Battery charging coil		0.1 - 1 Ω
Trigger coil		190 - 300 Ω
Ignition coil	Primary	0.33 - 0.62 Ω
	Secondary	8.4 - 15.6 k Ω
Engine rev limiter setting		7200 (± 50) RPM
Battery		(Yuasa/Exide) 12 V, 19 A•h
Fuse	Starting system	5 A
	Charging system	2 x 15 A
	VTS system	7.5 A
ADDITIONAL INFORMATION:		
CARBURETION		GSX (5624)
Carburetor	Type	Mikuni BN-40I-38 (diaphragm)
	Quantity	2
Main jet		142.5
Pilot jet		70
Spring		80 g
Adjustment	Low-speed screw	1 turn ± 1/4
	High-speed screw	0
	Idle speed (in water)	1500 RPM
	Idle speed (out of water)	3000 RPM
Fuel	Type	Regular unleaded gasoline
	Minimum octane no.	87
Fuel return line orifice		MAG and PTO: 0.8 mm (.031 in)
ADDITIONAL INFORMATION:		
COOLING		GSX (5624)
Type		Open circuit – Direct flow from jet propulsion unit
Thermostat		None
Monitoring beeper setting		86-94°C (187-201°F)
ADDITIONAL INFORMATION:		

Section 12 TECHNICAL DATA
Sub-Section 03 (GSX MODEL)

PROPULSION		GSX (5624)
Propulsion system		Bombardier Formula Pump
Jet pump type		Axial flow single stage
Impeller rotation (seen from rear)		Counterclockwise
Transmission		Direct drive
Coupling type		Crown splines
Oil type		SEA-DOO JET PUMP SYNTHETIC POLYOLESTER OIL 75W90 GL5
Steering nozzle pivoting angle		26°
Minimum required water level		90 cm (35 in)
Drive shaft deflection (maximum)		0.5 mm (.020 in)
Impeller outside diameter		139.5 mm (5.490 in)
Impeller/wear ring clearance	New	0.0 - 0.4 mm (.000 - .016 in)
	Wear limit	1.00 mm (.040 in)
Impeller shaft end play (new)		0.12 - 0.54 mm (.005 - .021 in)
Impeller shaft side play		0.05 mm (.002 in)
Impeller pitch/material		Progressive pitch 16° - 23°/stainless steel
ADDITIONAL INFORMATION: Do not mix different brands or oil types.		
DIMENSIONS		GSX (5624)
Number of passenger (driver incl.)		2
Overall length		267 cm (105 in)
Overall width		116 cm (45.7 in)
Overall height		94 cm (37 in)
Dry weight		227 kg (500 lb)
Load limit (passenger and 10 kg (22 lb) luggage)		165 kg (364 lb)
ADDITIONAL INFORMATION:		
CAPACITIES		GSX (5624)
Fuel tank		56.5 L (15 U.S. gal)
Impeller shaft reservoir	Capacity	70 mL (2.4 U.S. oz)
	Oil level height	Up to plug
Oil injection reservoir		6 L (1.6 U.S. gal)
ADDITIONAL INFORMATION:		

Section 12 TECHNICAL DATA

Sub-Section 03 (GSX MODEL)

MATERIALS		GSX (5624)
Hull		Composite
Inlet grate		Aluminum
Impeller housing/stator/venturi/nozzle		Plastic/brass/plastic/aluminum
Air intake silencer		Thermoplastic
Flame arrester		Multi-layer wire screen
Exhaust muffler		Aluminum
Steering padding		Thermoplastic with polyethylene foam
Fuel tank		Polyethylene
Oil injection reservoir		Polyethylene
Seat		Polyurethane foam
ADDITIONAL INFORMATION:		
STANDARD EQUIPMENT		GSX (5624)
Safety lanyard		Standard
Digitally Encoded Security System		Standard
Fuel tank reserve		Standard
Monitoring beeper		Standard
Speedometer		Standard
Info Center gauge		Standard
Variable trim system (VTS)		Standard
Reverse		Not applicable
Storage compartment		Standard
Rear grab handle		Standard
Extinguisher holder		Standard
Tool kit		Standard
ADDITIONAL INFORMATION: Info Center standard functions: Fuel level/low fuel level/low oil level/low voltage/high temperature/tachometer/hour meter/clock/maintenance information/speedometer/average speed/peak speed/chronometer/trim		
PERFORMANCE		GSX (5624)
Estimated pump power		42 kW (56 hp)
Maximum fuel consumption at wide open throttle		44.5 L/h (11.7 U.S. gal/h)
Cruising time at full throttle	Fuel tank without reserve	1 hour 1 minutes
	Fuel tank reserve	15 minutes
ADDITIONAL INFORMATION:		

Section 12 TECHNICAL DATA
Sub-Section 03 (GSX MODEL)

TIGHTENING TORQUES		GSX (5624)			
ENGINE	Exhaust manifold screw		40 N•m (30 lbf•ft)	(3) (4)	
	Magneto flywheel nut		105 N•m (77 lbf•ft)	(1)	
	Flywheel (PTO side)		110 N•m (81 lbf•ft)		
	Crankcase screws	M8		24 N•m (17 lbf•ft)	(3) (4)
		M10		40 N•m (30 lbf•ft)	(3) (4)
	Crankcase/engine support nuts		35 N•m (26 lbf•ft)	(1)	
	Engine mount/hull		25 N•m (18 lbf•ft)	(1)	
	Cylinder head screws		24 N•m (17 lbf•ft)	(1) (4)	
	Crankcase/cylinder screws		40 N•m (30 lbf•ft)	(3) (4)	
	Tuned pipe flange screws/nut		40 N•m (30 lbf•ft)	(1)	
	Tuned pipe fixation screws		25 N•m (18 lbf•ft)	(1)	
	Flame arrester screws		10 N•m (88 lbf•in)	(1)	
	Magneto housing cover screws		9 N•m (80 lbf•in)	(5)	
	Starter mounting screws		22 N•m (16 lbf•ft)	(1)	
	Starter lock nuts		7 N•m (62 lbf•in)		
Spark plugs		24 N•m (17 lbf•ft)	(5)		
JET PUMP	Impeller		70 N•m (52 lbf•ft)	(2)	
	Pump/hull nuts		31 N•m (23 lbf•ft)	(1)	
	Venturi/pump housing screws		21 N•m (16 lbf•ft)	(1)	
	VTS ring screws		14 N•m (10 lbf•ft)	(1)	
	Pump housing cover screws		4 N•m (35 lbf•in)	(1)	
	Inlet grate screws		8 N•m (71 lbf•in)	(1)	
	Riding plate screws		22 N•m (16 lbf•ft)	(1)	
STEERING	Cable retaining block bolts		6 N•m (53 lbf•in)		
	Steering cable/stem arm bolt		3 N•m (26 lbf•in)		
	Steering stem arm bolts		6 N•m (53 lbf•in)		
	Handlebar clamp bolts		26 N•m (19 lbf•ft)		
	Steering cable ball joint bolt (nozzle)		7 N•m (62 lbf•in)		
	Steering support bolts		15 N•m (11 lbf•ft)	(1)	
	Handlebar grip screw		14 N•m (10 lbf•ft)		
ADDITIONAL INFORMATION: apply where indicated; (1) Loctite 242 (blue) (2) Loctite 271 (red) (3) Loctite 515 (4) Synthetic grease (5) Anti-seize lubricant <p align="center">◆ WARNING: Correct torques and use of Loctite must be strictly followed.</p>					

GTS MODEL

ENGINE		GTS (5818)
Engine type		Bombardier-Rotax 717
Induction type		Rotary valve
Exhaust system	Type	Water cooled, water injected
	Water injection fitting (head)	3.5 mm (.139 in)
	Water injection fitting (cone)	3.5 mm (.139 in)
Starting system		Electric start
Lubrication	Fuel/oil mixture	VROI (Variable Rate Oil Injection)
	Oil injection pump	Gear driven
	Oil type	BOMBARDIER-ROTAX injection oil
Number of cylinders		2
Bore	Standard	82 mm (3.228 in)
	First oversize	82.25 mm (3.238 in)
	Second oversize	82.50 mm (3.248 in)
Stroke		68 mm (2.68 in)
Displacement		718.2 cm ³ (43.81 in ³)
Corrected compression ratio		6.2: 1
Cylinder head warpage (maximum)		0.05 mm (.002 in)
Piston ring type and quantity		1 Semi-Trapez – 1 Rectangular
Ring end gap	New	0.25 - 0.40 mm (.010 - .016 in)
	Wear limit	1.00 mm (.039 in)
Ring/piston groove clearance	New	0.025 - 0.070 mm (.001 - .003 in)
	Wear limit	0.2 mm (.008 in)
Piston/cylinder wall clearance	New (minimum)	0.100 mm (.0039 in)
	Wear limit	0.200 mm (.008 in)
Cylinder taper (maximum)		0.100 mm (.004 in)
Cylinder out of round (maximum)		0.080 mm (.003 in)
Connecting rod big end axial play	New	0.311 - 0.678 mm (.012 - .027 in)
	Wear limit	1.2 mm (.047 in)
Crankshaft deflection		MAG side: 0.05 mm (.002 in) PTO side: 0.03 mm (.001 in)
Rotary valve timing	Opening	147° ± 5 BTDC
	Closing	65.5° ± 5 ATDC
Rotary valve duration		159°
Rotary valve/cover clearance		0.25 - 0.35 mm (.010 - .014 in)
Connecting rod/crankshaft pin radial clearance	New	0.020 - 0.033 mm (.0008 - .0013 in)
	Wear limit	0.050 mm (.002 in)
Connecting rod/piston pin radial clearance	New	0.003 - 0.012 mm (.00012 - .00047 in)
	Wear limit	0.015 mm (.00059 in)
ADDITIONAL INFORMATION:		

Section 12 TECHNICAL DATA

Sub-Section 04 (GTS MODEL)

ELECTRICAL		GTS (5818)
Magneto generator output		160 W @ 6000 RPM or 4.0 A @ 2000 RPM
Ignition system type		Digital CDI
Spark plug	Make and type	NGK BR8ES
	Gap	0.5 - 0.6 mm (.020 - .024 in)
Ignition timing (BTDC)	mm (in)	2.59 (.102)
	Degrees	20° ± 1 Ⓢ
Generating coil		40 - 76 Ω
Battery charging coil		0.05 - 0.6 Ω
Ignition coil	Primary	Not applicable
	Secondary	9 - 15 kΩ
Engine rev limiter setting		7000 ± 50 RPM
Battery		(Yuasa/Exide) 12 V, 19 A•h
Fuse	Starting system	5 A
	Charging system	15 A
ADDITIONAL INFORMATION: Engine cold @ 6000 RPM.		
CARBURETION		GTS (5818)
Carburetor	Type	Mikuni BN-40I (diaphragm)
	Quantity	1
Main jet		175
Pilot jet		70
Spring		80 g
Adjustment	Low-speed screw	1-3/4 turn ± 1/4
	High-speed screw	0
	Idle speed (in water)	1500 RPM
	Idle speed (out of water)	3000 RPM
Fuel	Type	Regular unleaded gasoline
	Minimum octane no.	87
Fuel return line orifice		0.8 mm (.031 in)
ADDITIONAL INFORMATION:		
COOLING		GTS (5818)
Type		Open circuit – Direct flow from jet propulsion unit
Thermostat		None
Monitoring beeper setting		95-103°C (203-217°F)
ADDITIONAL INFORMATION:		

Section 12 TECHNICAL DATA
Sub-Section 04 (GTS MODEL)

PROPULSION		GTS (5818)
Propulsion system		Bombardier Formula Pump
Jet pump type		Axial flow single stage
Impeller rotation (seen from rear)		Counterclockwise
Transmission		Direct drive
Coupling type		Crown splines
Oil type		SEA-DOO JET PUMP SYNTHETIC POLYOLESTER OIL 75W90 GL5
Steering nozzle pivoting angle		26°
Minimum required water level		90 cm (35 in)
Drive shaft deflection (maximum)		0.5 mm (.020 in)
Impeller outside diameter		139.5 mm (5.490 in)
Impeller/wear ring clearance	New	0.0 - 0.4 mm (.000 - .016 in)
	Wear limit	1.00 mm(.040 in)
Impeller shaft end play (new)		0.12 - 0.54 mm (.005 - .021 in)
Impeller shaft side play		0.05 mm (.002 in)
Impeller pitch/material		Progressive pitch, 11° - 22°/stainless steel
ADDITIONAL INFORMATION: Do not mix different brands or oil types.		
DIMENSIONS		GTS (5818)
Number of passenger (driver incl.)		3
Overall length		302 cm (119.0 in)
Overall width		119 cm (46.8 in)
Overall height		95 cm (37.4 in)
Dry weight		210 kg (463 lb)
Load limit (passenger and 10 kg (22 lb) luggage)		225 kg (496 lb)
ADDITIONAL INFORMATION:		
CAPACITIES		GTS (5818)
Fuel tank		47 L (12 U.S. gal)
Impeller shaft reservoir	Capacity	70 mL (2.4 U.S. oz)
	Oil level height	To bottom of cover hole
Oil injection reservoir		4.5 L (1.2 U.S. gal)
ADDITIONAL INFORMATION:		

Section 12 TECHNICAL DATA

Sub-Section 04 (GTS MODEL)

MATERIALS		GTS (5818)
Hull		Composite
Inlet grate		Plastic
Impeller housing/stator/venturi/nozzle		Plastic/brass/plastic/plastic
Air intake silencer		Thermoplastic
Flame arrester		Multi-layer wire screen
Exhaust muffler		Aluminum
Steering padding		Thermoplastic elastomer with polystyrene foam
Fuel tank		Polyethylene
Oil injection reservoir		Polyethylene
Seat		Polyurethane foam
ADDITIONAL INFORMATION:		
STANDARD EQUIPMENT		GTS (5818)
Safety lanyard		Standard
Digitally Encoded Security System		Standard
Fuel tank reserve		Standard
Monitoring beeper		Standard
Fuel gauge/low oil warning light		Standard
Tachometer		Optional
Speedometer		Optional
Variable trim system (VTS)		Not applicable
Reverse		Standard
Storage compartment		Standard
Rear grab handle		Standard
Extinguisher holder		Standard
Tool kit		Standard
ADDITIONAL INFORMATION:		
PERFORMANCE		GTS (5818)
Estimated pump power		34.9 kW (46.8 hp)
Maximum fuel consumption at wide open throttle		33.5 L/h (8.8 U.S. gal/h)
Cruising time at full throttle	Fuel tank without reserve	1 hour
	Fuel tank reserve	20 minutes
ADDITIONAL INFORMATION:		

Section 12 TECHNICAL DATA

Sub-Section 04 (GTS MODEL)

TIGHTENING TORQUES		GTS (5818)			
ENGINE	Exhaust manifold screws		24 N•m (17 lbf•ft)	(4)	
	Magneto flywheel nut		145 N•m (107 lbf•ft)	(1)	
	Flywheel (PTO side)		110 N•m (81 lbf•ft)	(5)	
	Crankcase screws	M8		24 N•m (17 lbf•ft)	(3) (4)
		M10		40 N•m (30 lbf•ft)	(3) (4)
	Crankcase/engine support nuts		35 N•m (26 lbf•ft)	(1)	
	Engine support/hull		25 N•m (18 lbf•ft)	(1)	
	Cylinder head screws		24 N•m (17 lbf•ft)	(1) (4)	
	Crankcase/cylinder screws		24 N•m (17 lbf•ft)	(1) (4)	
	Tuned pipe nut		25 N•m (18 lbf•ft)	(1)	
	Tuned pipe fixation screws		25 N•m (18 lbf•ft)	(1)	
	Flame arrester screws		10 N•m (88 lbf•in)	(1)	
	Magneto housing cover screws		9 N•m (80 lbf•in)	(5)	
	Starter mounting screws		22 N•m (16 lbf•ft)	(1)	
	Starter lock nuts		7 N•m (62 lbf•in)		
Spark plugs		24 N•m (17 lbf•ft)	(5)		
JET PUMP	Impeller		70 N•m (52 lbf•ft)	(2)	
	Pump/hull nuts		33 N•m (24 lbf•ft)	(1)	
	Venturi/pump housing screws		21 N•m (16 lbf•ft)	(1)	
	Nozzle/venturi screws		20 N•m (15 lbf•ft)	(1)	
	Pump housing cover screws		4 N•m (35 lbf•in)	(1)	
	Inlet grate screws		8 N•m (71 lbf•in)	(1)	
	Riding plate screws		10 N•m (88 lbf•in)	(1)	
STEERING	Steering cable jam nuts		10 N•m (88 lbf•in)		
	Steering support/collar screws		15 N•m (11 lbf•ft)	(1)	
	Steering stem screw		40 N•m (30 lbf•ft)	(2)	
	Handlebar nuts		26 N•m (19 lbf•ft)		
	Reverse gate screws		20 N•m (15 lbf•ft)	(1)	
	Steering cable ball joint (nozzle)		2 N•m (18 lbf•in)		
	Reverse cable ball joint nut		7 N•m (62 lbf•in)		
<p>ADDITIONAL INFORMATION: apply where indicated; (1) Loctite 242 (blue) (2) Loctite 271 (red) (3) Loctite 515 (4) Synthetic grease (5) Anti-seize lubricant</p> <p style="text-align: center;"> WARNING: Correct torques and use of Loctite must be strictly followed.</p>					

GTI AND GTX MODELS

ENGINE		GTI (5641)	GTX (5642)
Engine type		Bombardier-Rotax 717	Bombardier-Rotax 787
Induction type		Rotary valve	
Exhaust system	Type	Water cooled, water injected	Water cooled, water injected with regulator
	Water injection fitting (head)	3.5 mm (.139 in)	
	Water injection fitting (cone)	3.5 mm (.139 in)	Not applicable
	Water injection fitting (muffler)	Not applicable	3.5 mm (.139 in)
Exhaust valve		Not applicable	Rotax Adjustable Variable Exhaust (RAVE)
Starting system		Electric start	
Lubrication	Fuel/oil mixture	VROI (Variable Rate Oil Injection)	
	Oil injection pump	Gear driven	Direct driven
	Oil type	BOMBARDIER-ROTAX injection oil	
Number of cylinders		2	
Bore	Standard	82 mm (3.228 in)	
	First oversize	82.25 mm (3.238 in)	
	Second oversize	82.50 mm (3.248 in)	Not applicable
Stroke		68 mm (2.68 in)	74 mm (2.99 in)
Displacement		718.2 cm ³ (43.81 in ³)	781.6 cm ³ (47.7 in ³)
Corrected compression ratio		6.2: 1	6.0: 1
Cylinder head warpage (maximum)		0.05 mm (.002 in)	
Piston ring type and quantity		1 Semi-trapez – 1 Rectangular	
Ring end gap	New	0.25 - 0.40 mm (.010 - .016 in)	
	Wear limit	1.00 mm (.039 in)	
Ring/piston groove clearance	New	0.025 - 0.070 mm (.001 - .003 in)	
	Wear limit	0.2 mm (.008 in)	
Piston/cylinder wall clearance	New (minimum)	0.100 mm (.0039 in)	0.110 mm (.0043 in)
	Wear limit	0.200 mm (.008 in)	
Cylinder taper (maximum)		0.100 mm (.004 in)	
Cylinder out of round (maximum)		0.080 mm (.003 in)	
Connecting rod big end axial play	New	0.311 - 0.678 mm (.012 - .027 in)	0.230 - 0.617 (.009 - .024 in)
	Wear limit	1.2 mm (.047 in)	
Crankshaft deflection		MAG side: 0.050 mm (.002 in) PTO side: 0.030 mm (.001 in)	
Rotary valve timing	Opening	147° ± 5 BTDC	146.5° ± 5 BTDC
	Closing	65.5° ± 5 ATDC	64° ± 5 ATDC
Rotary valve duration		159°	
Crankcase/rotary valve gap		0.25 - 0.35 mm (.010 - .014 in)	
Connecting rod/crankshaft pin radial clearance	New	0.020 - 0.033 mm (.0008 - .0013 in)	0.023 - 0.034 mm (.0009 - .0013 in)
	Wear limit	0.050 mm (.002 in)	
Connecting rod/piston pin radial clearance	New	0.003 - 0.012 mm (.00012 - .00047 in)	
	Wear limit	0.015 mm (.00059 in)	
ADDITIONAL INFORMATION:			

Section 12 TECHNICAL DATA

Sub-Section 05 (GTI AND GTX MODELS)

ELECTRICAL		GTI (5641)	GTX (5642)
Magneto generator output		160 W @ 6000 RPM or 4.0 A @ 2000 RPM	180 W @ 6000 RPM or 5.0 A @ 6000 RPM
Ignition system type		Digital CDI	Digital DC-CDI
Spark plug	Make and type	NGK BR8ES	
	Gap	0.5 - 0.6 mm (.020 - .024 in)	
Ignition timing (BTDC)	mm (in)	2.59 (.102)	3.38 (.133)
	Degrees	20° ± 1 ①	22° ± 1 @ 3500 RPM
Generating coil		40 - 76 Ω	Not applicable
Battery charging coil		0.05 - 0.6 Ω	0.1 - 1 Ω
Trigger coil		Not applicable	190 - 300 Ω
Ignition coil	Primary	0.33 - 0.62 Ω	
	Secondary	8.4 - 15.6 kΩ	
Engine rev limiter setting		7000 (± 50) RPM	7200 (± 50) RPM
Battery		(Yuasa/Exide) 12 V, 19 A•h	
Fuse	Starting system	5 A	
	Charging system	2 x 15 A	
	VTS system	Not applicable	
ADDITIONAL INFORMATION: ① Engine cold @ 6000 RPM.			
CARBURETION		GTI (5641)	GTX (5642)
Carburetor	Type	Mikuni BN-40I (diaphragm)	
	Quantity	1	2
Main jet		175	142.5
Pilot jet		70	
Spring		80 g	
Adjustment	Low-speed screw	1-3/4 turn ± 1/4	1 turn ± 1/4
	High-speed screw	0	
	Idle speed (in water)	1500 RPM	
	Idle speed (out of water)	3000 RPM	
Fuel	Type	Regular unleaded gasoline	
	Minimum octane no.	87	
Fuel return line orifice		0.8 mm (.031 in)	MAG and PTO: 0.8 mm (.031 in)
ADDITIONAL INFORMATION:			
COOLING		GTI (5641)	GTX (5642)
Type		Open circuit – Direct flow from jet propulsion unit	
Thermostat		None	
Monitoring beeper setting		86-94°C (187-201°F)	
ADDITIONAL INFORMATION:			

Section 12 TECHNICAL DATA
Sub-Section 05 (GTI AND GTX MODELS)

PROPULSION		GTI (5641)	GTX (5642)
Propulsion system		Bombardier Formula Pump	
Jet pump type		Axial flow single stage	
Impeller rotation (seen from rear)		Counterclockwise	
Transmission		Direct drive	
Coupling type		Crown splines	
Oil type		SEA-DOO JET PUMP SYNTHETIC POLYOLESTER OIL 75W90 GL5	
Steering nozzle pivoting angle		23°	
Minimum required water level		90 cm (35 in)	
Drive shaft deflection (maximum)		0.5 mm (.020 in)	
Impeller outside diameter		139.5 mm (5.490 in)	
Impeller/wear ring clearance	New	0.0 - 0.4 mm (.000 - .016 in)	
	Wear limit	1.0 mm (.040 in)	
Impeller shaft end play (new)		0.12 - 0.54 mm (.005 - .021 in)	
Impeller shaft side play		0.05 mm (.002 in)	
Impeller pitch/material		Progressive pitch 11° - 22°/stainless steel	Progressive pitch 17° - 25°/stainless steel
ADDITIONAL INFORMATION: Do not mix different brands or oil types.			
DIMENSIONS		GTI (5641)	GTX (5642)
Number of passenger (driver incl.)		3	
Overall length		312 cm (122.8 in)	
Overall width		119 cm (47 in)	
Overall height		94 cm (37 in)	
Dry weight			262 kg (578 lb)
Load limit (passenger and 10 kg (22 lb) luggage)		230 kg (507 lb)	
ADDITIONAL INFORMATION:			
CAPACITIES		GTI (5641)	GTX (5642)
Fuel tank		56.5 L (15 U.S. gal)	
Impeller shaft reservoir	Capacity	70 mL (2.4 U.S. oz)	
	Oil level height	Up to plug	
Oil injection reservoir		6 L (1.6 U.S. gal)	
ADDITIONAL INFORMATION:			

Section 12 TECHNICAL DATA

Sub-Section 05 (GTI AND GTX MODELS)

MATERIALS		GTI (5641)	GTX (5642)
Hull		Composite	
Inlet grate		Aluminum	
Impeller housing/stator/venturi/nozzle		Plastic/brass/plastic/ plastic	
Air intake silencer		Thermoplastic	
Flame arrester		Multi-layer wire screen	
Exhaust muffler		Aluminum	
Steering padding		Thermoplastic with polyethylene foam	
Fuel tank		Polyethylene	
Oil injection reservoir		Polyethylene	
Seat		Polyurethane foam	
ADDITIONAL INFORMATION:			
STANDARD EQUIPMENT		GTI (5641)	GTX (5642)
Safety lanyard		Standard	
Digitally Encoded Security System		Standard	
Fuel tank reserve		Standard	
Monitoring beeper		Standard	
Speedometer		Standard	
Fuel/oil gauge (analog)		Standard	Not applicable
Tachometer		Not applicable	Standard
Info Center		Not applicable	Standard
Reverse		Standard	
Storage compartment		Standard	
Glove box		Standard	
Rear grab handle		Standard	
Extinguisher holder		Standard	
Tool kit		Standard	
ADDITIONAL INFORMATION: Info Center standard functions: Fuel level/low fuel level/low oil level/low voltage/high temperature/tachometer/speedometer/average speed/peak speed/trip meter/hour meter/clock/compass/exterior temperature/lake temperature/chronometer/maintenance information.			
PERFORMANCE		GTI (5641)	GTX (5642)
Estimated pump power		34.9 kW (46.8 hp)	42 kW (56 hp)
Maximum fuel consumption at wide open throttle		33.5 L/h (8.8 U.S. gal/h)	44.5 L/h (11.7 U.S. gal/h)
Cruising time at full throttle	Fuel tank without reserve	1 hour 21 minutes	1 hour 1 minute
	Fuel tank reserve	20 minutes	15 minutes
ADDITIONAL INFORMATION:			

Section 12 TECHNICAL DATA
Sub-Section 05 (GTI AND GTX MODELS)

TIGHTENING TORQUES		GTI (5641)	GTX (5642)	
ENGINE	Exhaust manifold screw	24 N•m (17 lbf•ft) (4)	40 N•m (30 lbf•ft) (3) (4)	
	Magneto flywheel nut	145 N•m (107 lbf•ft) (1)	105 N•m (77 lbf•ft) (1)	
	Flywheel (PTO side)	110 N•m (81 lbf•ft)	(5)	
	Crankcase screws	M8	24 N•m (17 lbf•ft)	(3) (4)
		M10	40 N•m (30 lbf•ft)	(3) (4)
	Crankcase/engine support nuts	35 N•m (26 lbf•ft)	(1)	
	Engine mount/hull	25 N•m (18 lbf•ft)	(1)	
	Cylinder head screws	24 N•m (17 lbf•ft)	(1) (4)	
	Crankcase/cylinder screws	24 N•m (17 lbf•ft) (1) (4)	40 N•m (30 lbf•ft) (3) (4)	
	Tuned pipe flange screws/nut	25 N•m (18 lbf•ft) (1)	40 N•m (30 lbf•ft) (1)	
	Tuned pipe fixation screws	25 N•m (18 lbf•ft)	(1)	
	Flame arrester screws	10 N•m (88 lbf•in)	(1)	
	Magneto housing cover screws	9 N•m (80 lbf•in)	(5)	
	Starter mounting screws	22 N•m (16 lbf•ft)	(1)	
	Starter lock nuts	7 N•m (62 lbf•in)		
Spark plugs	24 N•m (17 lbf•ft)	(5)		
JET PUMP	Impeller	70 N•m (52 lbf•ft)	(2)	
	Pump/hull nuts	31 N•m (23 lbf•ft)	(1)	
	Venturi/pump housing screws	21 N•m (16 lbf•ft)	(1)	
	Pump housing cover screws	4 N•m (35 lbf•in)	(1)	
	Inlet grate screws	8 N•m (71 lbf•in)	(1)	
	Riding plate screws	22 N•m (16 lbf•ft)	(1)	
STEERING	Cable retaining block bolts	6 N•m (53 lbf•in)		
	Steering cable/stem arm bolt	3 N•m (26 lbf•in)		
	Steering stem arm bolts	6 N•m (53 lbf•in)		
	Handlebar clamp bolts	26 N•m (19 lbf•ft)		
	Steering cable ball joint (nozzle)	2 N•m (18 lbf•in)		
	Steering support bolts	15 N•m (11 lbf•ft)	(1)	
	Handlebar grip screw	14 N•m (10 lbf•ft)		
<p>ADDITIONAL INFORMATION: apply where indicated; (1) Loctite 242 (blue) (2) Loctite 271 (red) (3) Loctite 515 (4) Synthetic grease (5) Anti-seize lubricant</p> <p style="text-align: center;">◆ WARNING: Correct torques and use of Loctite must be strictly followed.</p>				

HX AND XP MODELS

ENGINE		HX (5882)	XP (5662)
Engine type		Bombardier-Rotax 717	Bombardier-Rotax 787
Induction type		Rotary valve	
Exhaust system	Type	Water cooled, water injected	Water cooled, water injected with regulator
	Water injection fitting (head)	3.5 mm (.139 in)	
	Water injection fitting (cone)	3.5 mm (.139 in)	Not applicable
	Water injection fitting (muffler)	Not applicable	3.5 mm (.139 in)
Exhaust valve		Not applicable	Rotax Adjustable Variable Exhaust (RAVE)
Starting system		Electric start	
Lubrication	Fuel/oil mixture	VROI (Variable Rate Oil Injection)	
	Oil injection pump	Gear driven	Direct driven
	Oil type	BOMBARDIER-ROTAX injection oil	
Number of cylinders		2	
Bore	Standard	82 mm (3.228 in)	
	First oversize	82.25 mm (3.238 in)	
	Second oversize	82.50 mm (3.248 in)	Not applicable
Stroke		68 mm (2.68 in)	74 mm (2.99 in)
Displacement		718.2 cm ³ (43.81 in ³)	781.6 cm ³ (47.7 in ³)
Corrected compression ratio		6.2: 1	6.0: 1
Cylinder head warpage (maximum)		0.05 mm (.002 in)	
Piston ring type and quantity		1 Semi-trapez – 1 Rectangular	
Ring end gap	New	0.25 - 0.40 mm (.010 - .016 in)	
	Wear limit	1.00 mm (.039 in)	
Ring/piston groove clearance	New	0.025 - 0.070 mm (.001 - .003 in)	
	Wear limit	0.2 mm (.008 in)	
Piston/cylinder wall clearance	New (minimum)	0.100 mm (.0039 in)	0.110 mm (.0043 in)
	Wear limit	0.200 mm (.008 in)	
Cylinder taper (maximum)		0.100 mm (.004 in)	
Cylinder out of round (maximum)		0.080 mm (.003 in)	
Connecting rod big end axial play	New	0.311 - 0.678 mm (.012 - .027 in)	0.230 - 0.617 (.009 - .024 in)
	Wear limit	1.2 mm (.047 in)	
Crankshaft deflection		MAG side: 0.050 mm (.002 in) PTO side: 0.030 mm (.001 in)	
Rotary valve timing	Opening	147° ± 5 BTDC	146.5° ± 5 BTDC
	Closing	65.5° ± 5 ATDC	64° ± 5 ATDC
Rotary valve duration		159°	
Crankcase/rotary valve gap		0.25 - 0.35 mm (.010 - .014 in)	
Connecting rod/crankshaft pin radial clearance	New	0.020 - 0.033 mm (.0008 - .0013 in)	0.023 - 0.034 mm (.0009 - .0013 in)
	Wear limit	0.050 mm (.002 in)	
Connecting rod/piston pin radial clearance	New	0.003 - 0.012 mm (.00012 - .00047 in)	
	Wear limit	0.015 mm (.00059 in)	
ADDITIONAL INFORMATION:			

Section 12 TECHNICAL DATA

Sub-Section 06 (HX AND XP MODELS)

ELECTRICAL		HX (5882)	XP (5662)
Magneto generator output		160 W @ 6000 RPM or 4.0 A @ 2000 RPM	180 W @ 6000 RPM or 5.0 A @ 6000 RPM
Ignition system type		Digital CDI	Digital DC-CDI
Spark plug	Make and type	NGK BR8ES	
	Gap	0.5 - 0.6 mm (.020 - .024 in)	
Ignition timing (BTDC)	mm (in)	2.59 (.102)	3.38 (.133)
	Degrees	20° ± 1 ①	22° ± 1 @ 3500 RPM
Generating coil		40 - 76 Ω	Not applicable
Battery charging coil		0.05 - 0.6 Ω	0.1 - 1 Ω
Trigger coil		Not applicable	190 - 300 Ω
Ignition coil	Primary	Not applicable	0.33 - 0.62 Ω
	Secondary	9 - 15 kΩ	8.4 - 15.6 kΩ
Engine rev limiter setting		7000 (± 50) RPM	7200 (± 50) RPM
Battery		(Yuasa/Exide) 12 V, 19 A•h	
Fuse	Starting system	5 A	
	Charging system	15 A	2 x 15 A
	VTS system	Not applicable	7.5 A
ADDITIONAL INFORMATION: ① Engine cold @ 6000 RPM.			
CARBURETION		HX (5882)	XP (5662)
Carburetor	Type	Mikuni BN-38I (diaphragm)	Mikuni BN-40I (diaphragm)
	Quantity	2	
Main jet		130	142.5
Pilot jet		75	70
Spring		80 g	
Adjustment	Low-speed screw	1-1/2 turn ± 1/4	1 turn ± 1/4
	High-speed screw	0	
	Idle speed (in water)	1500 RPM	
	Idle speed (out of water)	3000 RPM	
Fuel	Type	Regular unleaded gasoline	
	Minimum octane no.	87	
Fuel return line orifice		MAG and PTO: 0.8 mm (.031 in)	
ADDITIONAL INFORMATION:			
COOLING		HX (5882)	XP (5662)
Type		Open circuit – Direct flow from jet propulsion unit	
Thermostat		None	
Monitoring beeper setting		86-94°C (187-201°F)	
ADDITIONAL INFORMATION:			

Section 12 TECHNICAL DATA
Sub-Section 06 (HX AND XP MODELS)

PROPULSION		HX (5882)	XP (5662)
Propulsion system		Bombardier Formula Pump	
Jet pump type		Axial flow single stage	
Impeller rotation (seen from rear)		Counterclockwise	
Transmission		Direct drive	
Coupling type		Crown splines	
Oil type		SEA-DOO JET PUMP SYNTHETIC POLYOLESTER OIL 75W90 GL5	
Steering nozzle pivoting angle		26°	
Minimum required water level		90 cm (35 in)	
Drive shaft deflection (maximum)		0.5 mm (.020 in)	
Impeller outside diameter		139.5 mm (5.490 in)	
Impeller/wear ring clearance	New	0.0 - 0.4 mm (.000 - .016 in)	
	Wear limit	1.0 mm (.040 in)	
Impeller shaft end play (new)		0.12 - 0.54 mm (.005 - .021 in)	
Impeller shaft side play		0.05 mm (.002 in)	
Impeller pitch/material		Progressive pitch 11° - 22°/stainless steel	Progressive pitch 16° - 23°/stainless steel
ADDITIONAL INFORMATION: Do not mix different brands or oil types.			
DIMENSIONS		HX (5882)	XP (5662)
Number of passenger (driver incl.)		1	2
Overall length		273 cm (107.5 in)	272 cm (107 in)
Overall width		85 cm (33.5 in)	111 cm (43.7 in)
Overall height		97 cm (38.2 in)	103 cm (40.6 in)
Dry weight		177 kg (390 lb)	238 kg (525 lb)
Load limit		110 kg (250 lb)	
ADDITIONAL INFORMATION:			
CAPACITIES		HX (5882)	XP (5662)
Fuel tank		27 L (7 U.S. gal)	41.5 L (11 U.S. gal)
Impeller shaft reservoir	Capacity	70 mL (2.4 U.S. oz)	
	Oil level height	Up to plug	
Oil injection reservoir		4 L (1 U.S. gal)	
ADDITIONAL INFORMATION:			

Section 12 TECHNICAL DATA

Sub-Section 06 (HX AND XP MODELS)

MATERIALS		HX (5882)	XP (5662)
Hull		Composite	
Inlet grate		Aluminum	
Impeller housing/stator/venturi/nozzle		Plastic/brass/plastic/ plastic	
Air intake silencer		Thermoplastic	
Flame arrester		Multi-layer wire screen	
Exhaust muffler		Aluminum	
Steering padding		Thermoplastic elastomer with polystyrene foam	Thermoplastic with polyethylene foam
Fuel tank		Polyethylene	
Oil injection reservoir		Polyethylene	
Seat		Polyurethane foam	
ADDITIONAL INFORMATION:			
STANDARD EQUIPMENT		HX (5882)	XP (5662)
Safety lanyard		Standard	
Digitally Encoded Security System		Standard	
Fuel tank reserve		Standard	
Monitoring beeper		Standard	
Speedometer		Not applicable	Standard
Tachometer		Optional	
Fuel/oil gauge (analog)		Standard	
VTS gauge		Not applicable	Standard
Info Center		Not applicable	
Variable trim system (VTS)		Standard (manual)	Standard
Reverse		Not applicable	
Storage compartment		Not applicable	
Rear grab handle		Standard	
Extinguisher holder		Standard	
Tool kit		Standard	
ADDITIONAL INFORMATION:			
PERFORMANCE		HX (5882)	XP (5662)
Estimated pump power		34.9 kW (46.8 hp)	42 kW (56 hp)
Maximum fuel consumption at wide open throttle		33.5 L/h (8.8 U.S. gal/h)	44.5 L/h (11.7 U.S. gal/h)
Cruising time at full throttle	Fuel tank without reserve	35 minutes	
	Fuel tank reserve	10 minutes	
ADDITIONAL INFORMATION:			

Section 12 TECHNICAL DATA
Sub-Section 06 (HX AND XP MODELS)

TIGHTENING TORQUES		HX (5882)	XP (5662)	
ENGINE	Exhaust manifold screw	24 N•m (17 lbf•ft) (4)	40 N•m (30 lbf•ft) (3) (4)	
	Magneto flywheel nut	145 N•m (107 lbf•ft) (1)	105 N•m (77 lbf•ft) (1)	
	Flywheel (PTO side)	110 N•m (81 lbf•ft)	(5)	
	Crankcase screws	M8	24 N•m (17 lbf•ft)	(3) (4)
		M10	40 N•m (30 lbf•ft)	(3) (4)
	Crankcase/engine support nuts	35 N•m (26 lbf•ft)	(1)	
	Engine mount/hull	25 N•m (18 lbf•ft)	(1)	
	Cylinder head screws	24 N•m (17 lbf•ft)	(1) (4)	
	Crankcase/cylinder screws	24 N•m (17 lbf•ft) (1) (4)	40 N•m (30 lbf•ft) (3) (4)	
	Tuned pipe flange screws/nut	25 N•m (18 lbf•ft) (1)	40 N•m (30 lbf•ft) (1)	
	Tuned pipe fixation screws	25 N•m (18 lbf•ft)	(1)	
	Flame arrester screws	10 N•m (88 lbf•in)	(1)	
	Magneto housing cover screws	9 N•m (80 lbf•in)	(5)	
	Starter mounting screws	22 N•m (16 lbf•ft)	(1)	
	Starter lock nuts	7 N•m (62 lbf•in)		
Spark plugs	24 N•m (17 lbf•ft)	(5)		
JET PUMP	Impeller	70 N•m (52 lbf•ft)	(2)	
	Pump/hull nuts	31 N•m (23 lbf•ft)	(1)	
	Venturi/pump housing screws	21 N•m (16 lbf•ft)	(1)	
	Pump housing cover screws	4 N•m (35 lbf•in)	(1)	
	Inlet grate screws	8 N•m (71 lbf•in)	(1)	
	Riding plate screws	10 N•m (88 lbf•in)	(1)	
STEERING	Cable retaining block bolts	6 N•m (53 lbf•in)		
	Steering cable/lever	3 N•m (26 lbf•in)		
	Steering stem arm bolts	6 N•m (53 lbf•in)		
	Handlebar clamp bolts	26 N•m (19 lbf•ft)		
	Steering cable ball joint (nozzle)	7 N•m (62 lbf•in)		
	Steering support bolts	15 N•m (11 lbf•ft)		
	Lever pivot bolt	6 N•m (53 lbf•in)		
	Handlebar grip screw	14 N•m (10 lbf•ft)		
<p>ADDITIONAL INFORMATION: apply where indicated; (1) Loctite 242 (blue) (2) Loctite 271 (red) (3) Loctite 515 (4) Synthetic grease (5) Anti-seize lubricant</p> <p style="text-align: center;"> WARNING: Correct torques and use of Loctite must be strictly followed.</p>				

WIRING DIAGRAMS

WIRE COLOR CODES

First color of a wire is the main color. Second color is the tracer.

Example: YELLOW/BLACK is a YELLOW wire with a BLACK tracer.

WIRE DIGIT CODES

GS, GSI, GSX, GTI and XP Models

First number indicates in which connector the wire is plugged in.

Second number indicates the position of the wire in the connector.

The letter at the end of the number (if applicable) indicates a common circuit in the MPEM printed circuit with another wire bearing the same letter.

Example: 2-18 (g)

The first number indicates that the wire is positioned in the connector **no. 2** of the MPEM.

The second number indicates that the wire is positioned in the terminal **no. 18**.

The letter (g) indicates a common circuit with another wire(s) bearing the same letter (g) in the circuit.

WIRE TERMINAL REMOVAL

To remove terminal from connector housing, use Snap-on TT600-4 tool.

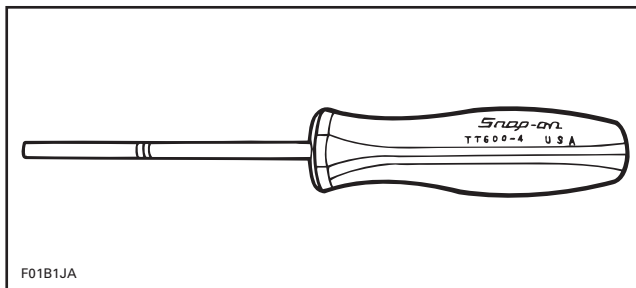

◆ **WARNING**

Ensure all terminals are properly crimped on wires and connector housings are properly fastened.

AMP CONNECTOR

GS, GSI, GSX, GTI and XP Models

These connectors are found on the MPEM of the aforementioned watercraft.

Description

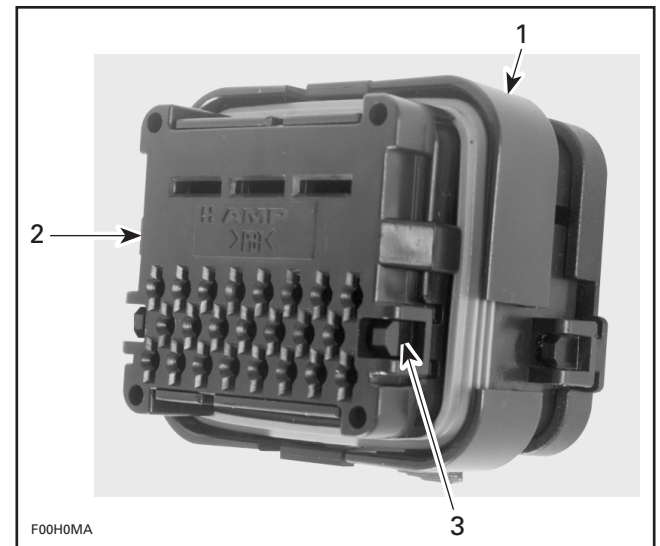

PLUG CONNECTOR

1. Housing
2. Wedge lock
3. Locking tab

Removal

To remove the plug connector from the header assembly, press both tabs and pull plug.

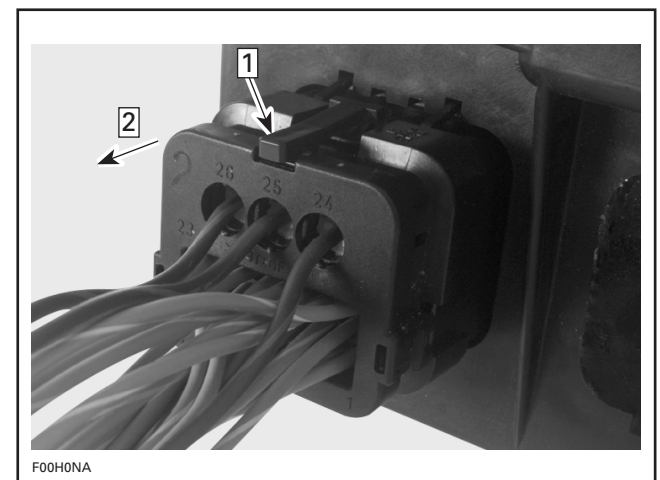

- Step **1**: Press tabs (both sides)
Step **2**: Pull plug

Section 13 WIRING DIAGRAMS

Sub-Section 01 (WIRING DIAGRAMS)

Contact Removal

Insert a screwdriver blade between the housing and wedge lock on the lock tab side.

Pry the wedge lock to unlock the tab (open position).

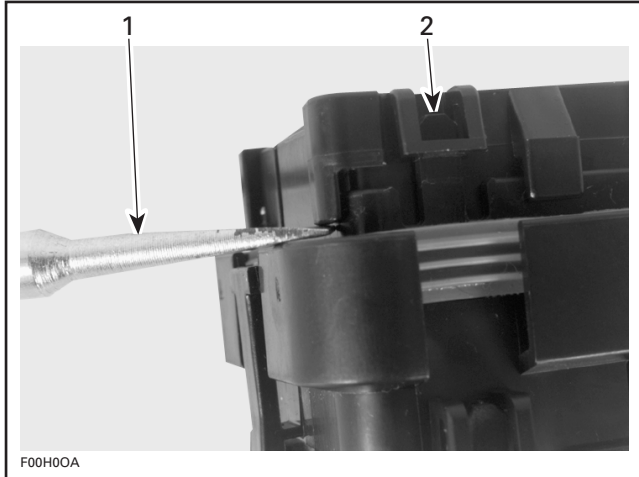

1. Screwdriver between wedge lock and housing
2. Locking tab

Repeat the same steps for the other locking tab retaining the wedge lock.

The wedge lock is now in the open position.

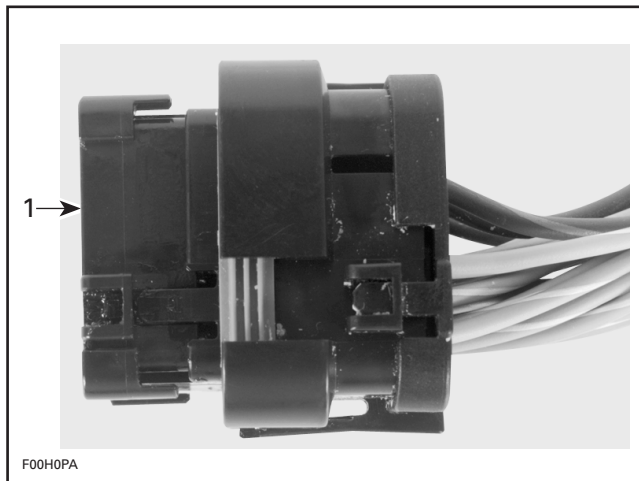

1. Wedge lock opened

While rotating the wire back and forth over a half turn (1/4 turn in each direction), gently pull the wire until the contact is removed.



1. Rotate wire back and forth
2. Pull wire



CAUTION

The wedge lock should never be removed from the housing for insertion or removal of the contacts.

Contact Installation

Make sure the wedge lock is in the **open** position.

To insert a contact, push it straight into the appropriate circuit cavity as far as it will go.

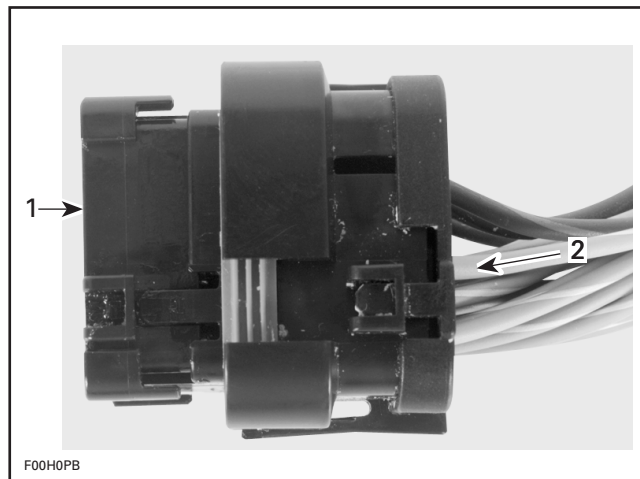

1. Wedge lock open
2. Push the wire

Pull back on the contact wire to be sure the retention fingers in the housing are holding the contact properly.

After all required contacts have been inserted, the wedge lock must be closed to its **locked** position.

Release the locking tabs by squeezing them inward.

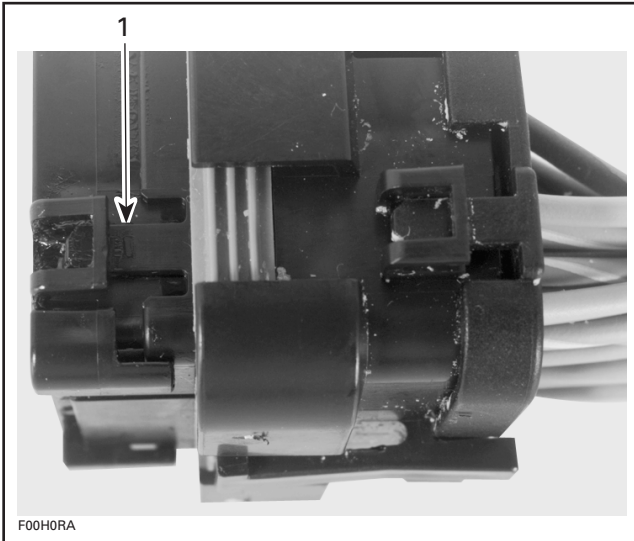

1. *Squeeze locking tab (both sides)*

Slide the wedge lock until it is flush with the housing.

SP MODEL 5879

MODEL SP '97

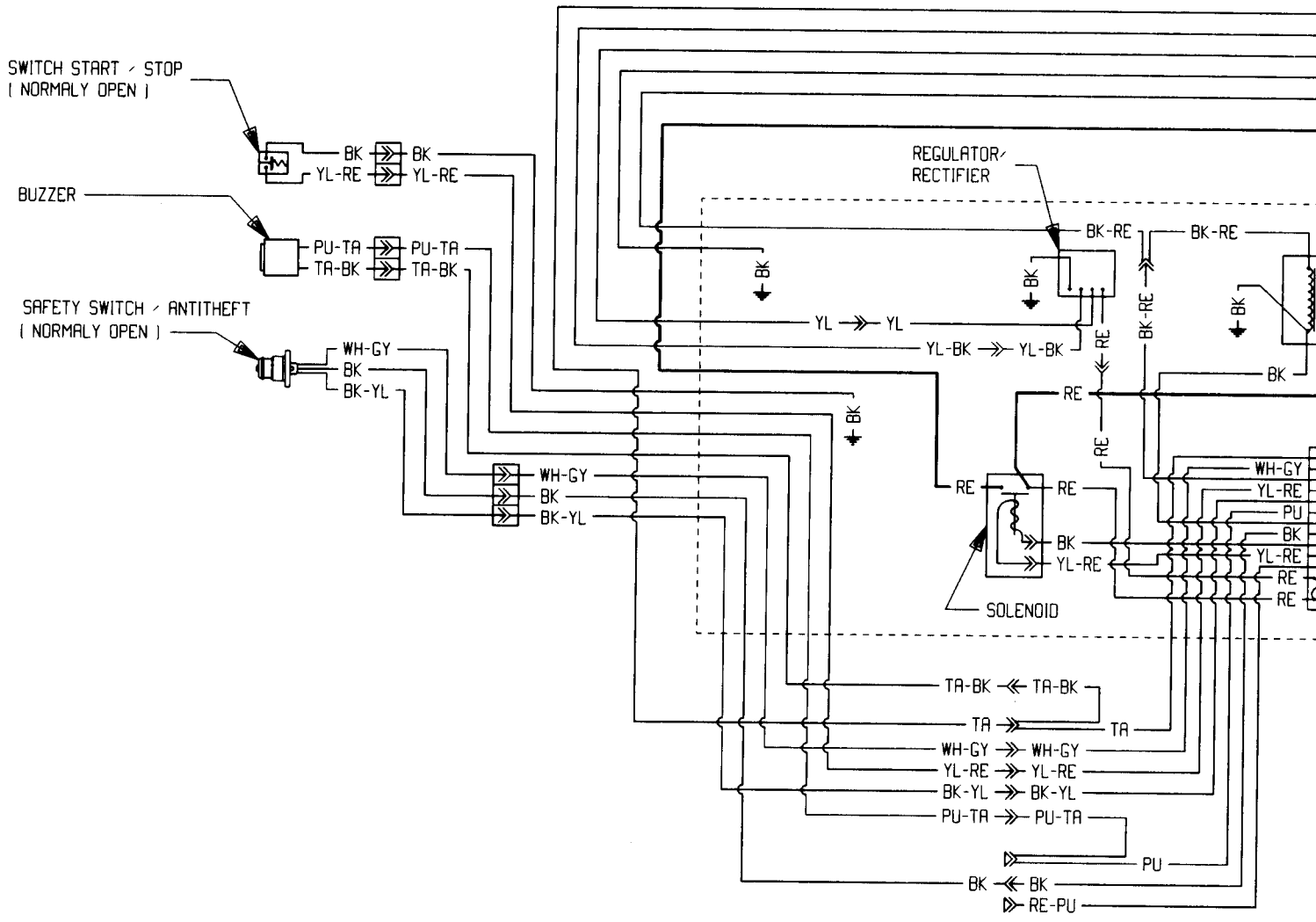

◆ WARN

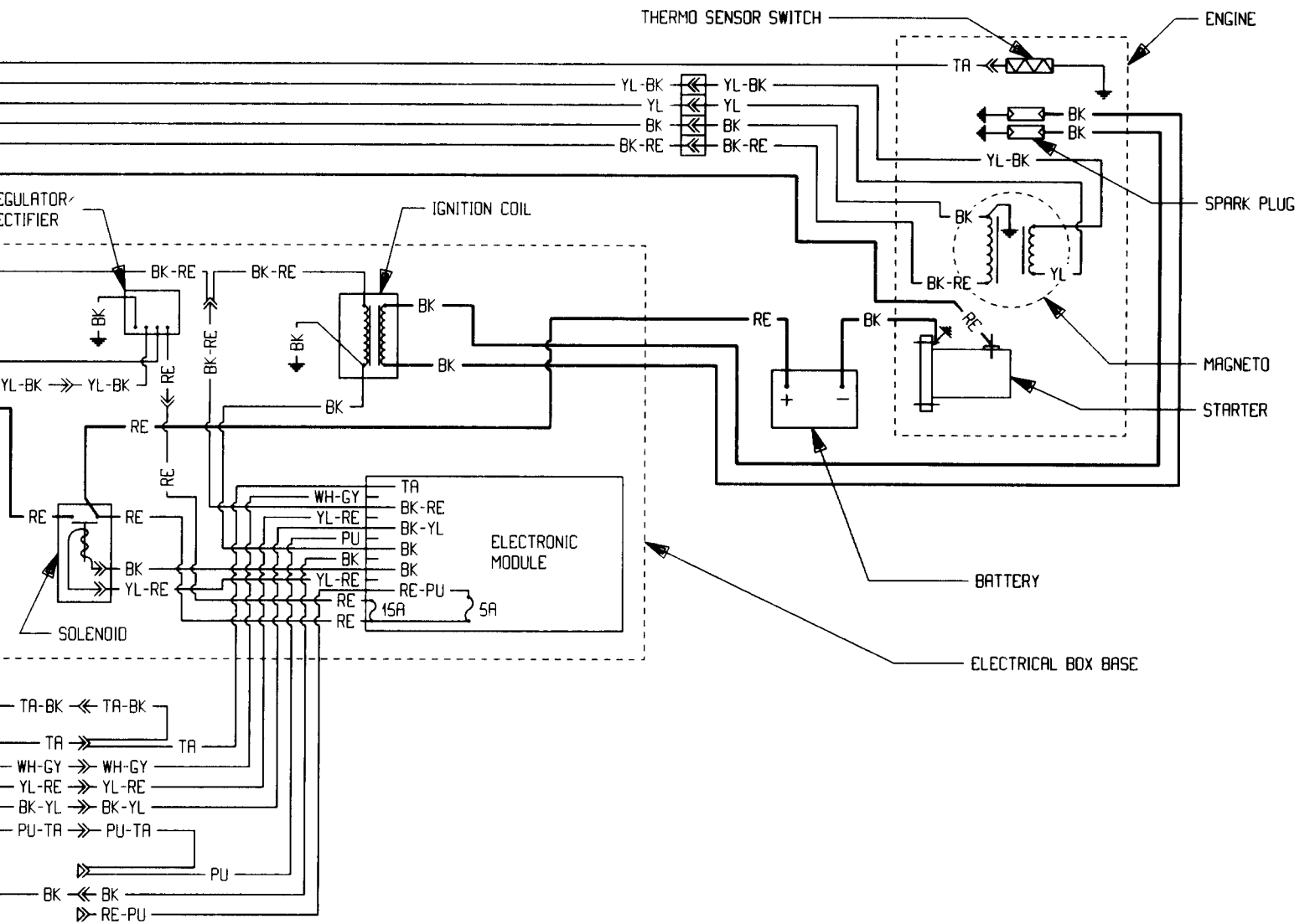

WARNING

- ENSURE ALL TERMINALS ARE PROPERLY CRIMPED ON THE WIRES AND ALL CONNECTOR HOUSING ARE PROPERLY FASTENED.

COLOR CODE	
WH = WHITE	BK = BLACK
RE = RED	YL = YELLOW
PU = PURPLE	TA = TAN
GY = GREY	

SPX MODEL

5834/5661

MODEL SPX '97

ELECTRICAL
BOX BASE

SWITCH START / STOP
(NORMALLY OPEN)

BUZZER

SAFETY SWITCH / ANTI THEFT
(NORMALLY OPEN)

ELECTRICAL
BOX COVER

VTS. GAUGE

PU-GY
BK-GY
BW-BK
BW-WH
BK-TA
PU-TA

OIL / FUEL GAUGE

PU
BK
PK
PK-BK
BL
BL-BK

OIL SENSOR

FUEL SENSOR

RECTIFIER

RE-PU
YL-RE
BK
GY

RE-PU
YL-RE
BK
GY

VTS SWITCH

DOWN

UP

◆ **WARNI**

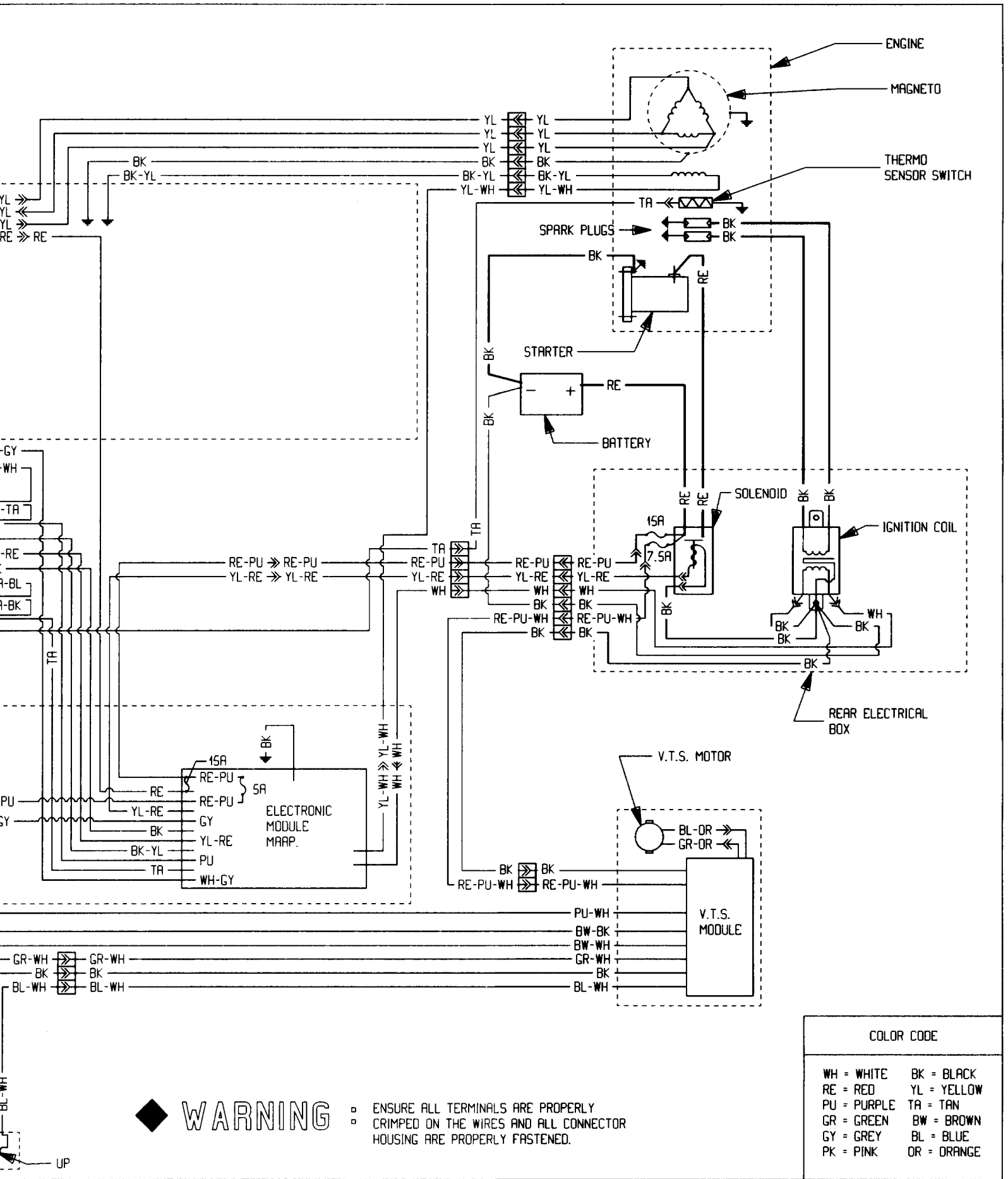

WARNING

- ENSURE ALL TERMINALS ARE PROPERLY CRIMPED ON THE WIRES AND ALL CONNECTOR HOUSING ARE PROPERLY FASTENED.

COLOR CODE	
WH = WHITE	BK = BLACK
RE = RED	YL = YELLOW
PU = PURPLE	TA = TAN
GR = GREEN	BW = BROWN
GY = GREY	BL = BLUE
PK = PINK	OR = ORANGE

GS MODEL 5621

MODEL GS '97

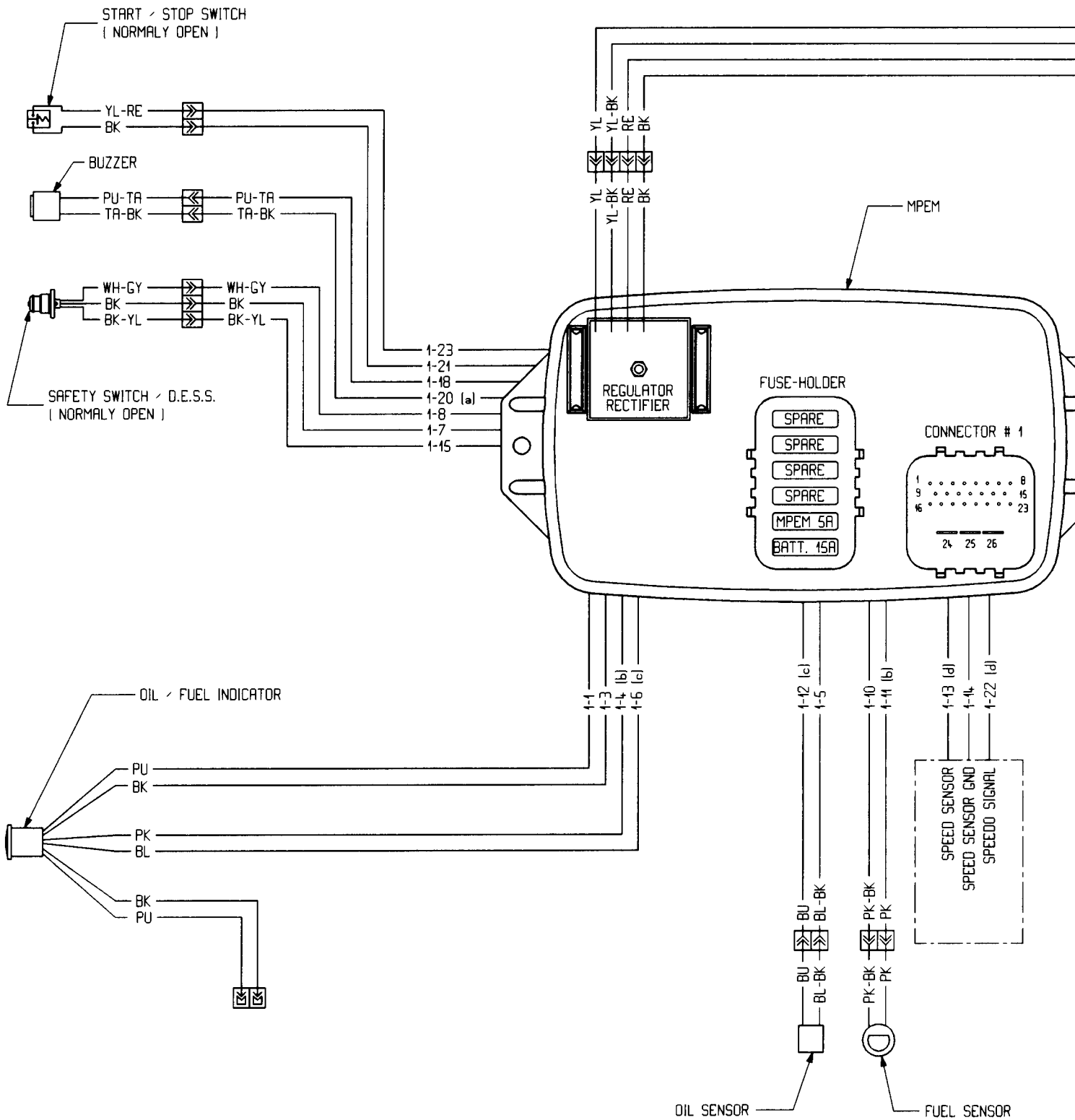

◆ WARNING

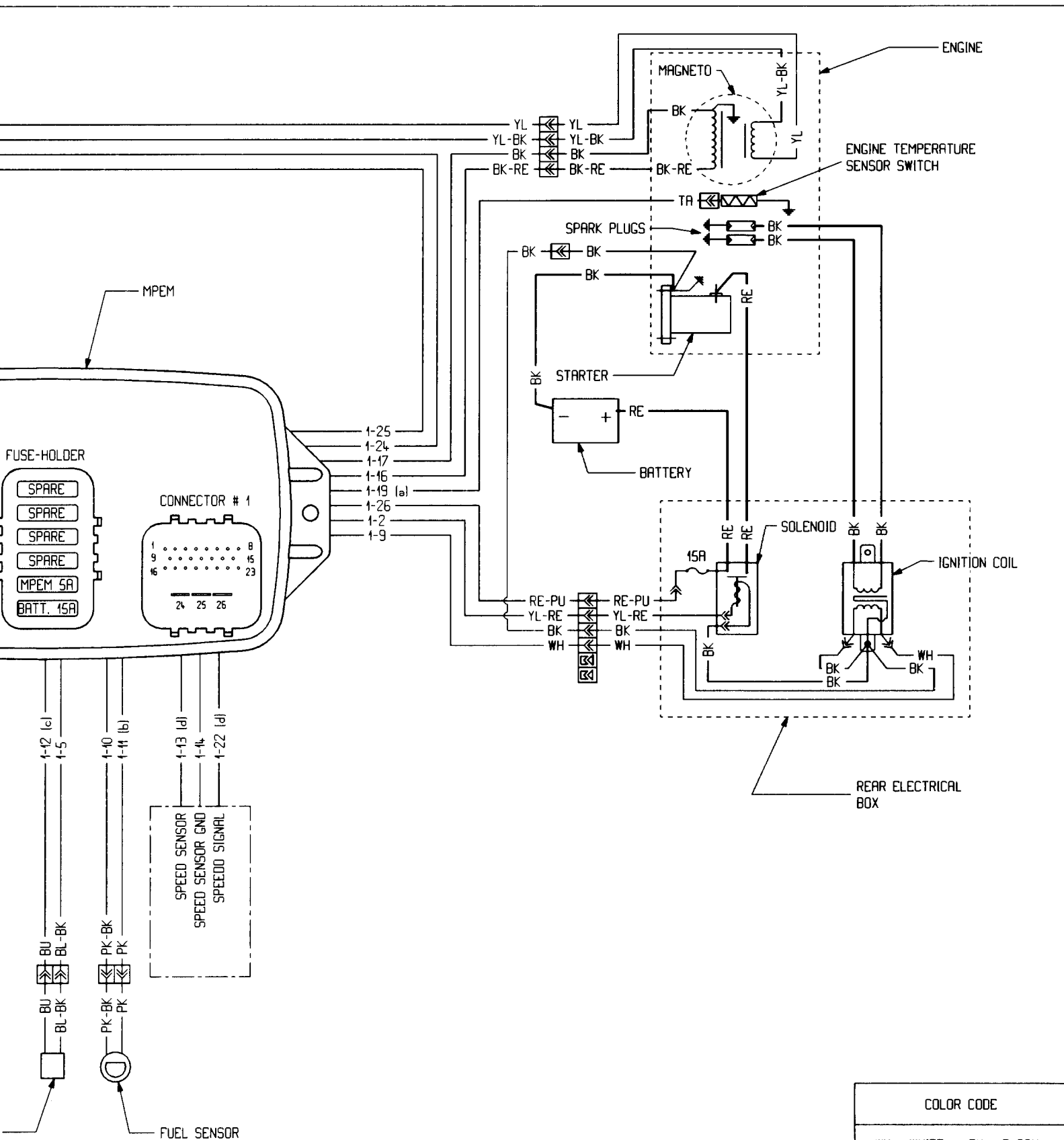

WARNING

- ENSURE ALL TERMINALS ARE PROPERLY CRIMPED ON THE WIRES AND ALL CONNECTOR HOUSING ARE PROPERLY FASTENED.

COLOR CODE	
WH = WHITE	BK = BLACK
RE = RED	YL = YELLOW
PU = PURPLE	TA = TAN
GR = GREEN	BW = BROWN
GY = GREY	BL = BLUE
PK = PINK	OR = ORANGE

GSI MODEL 5622

MODEL GSI '97

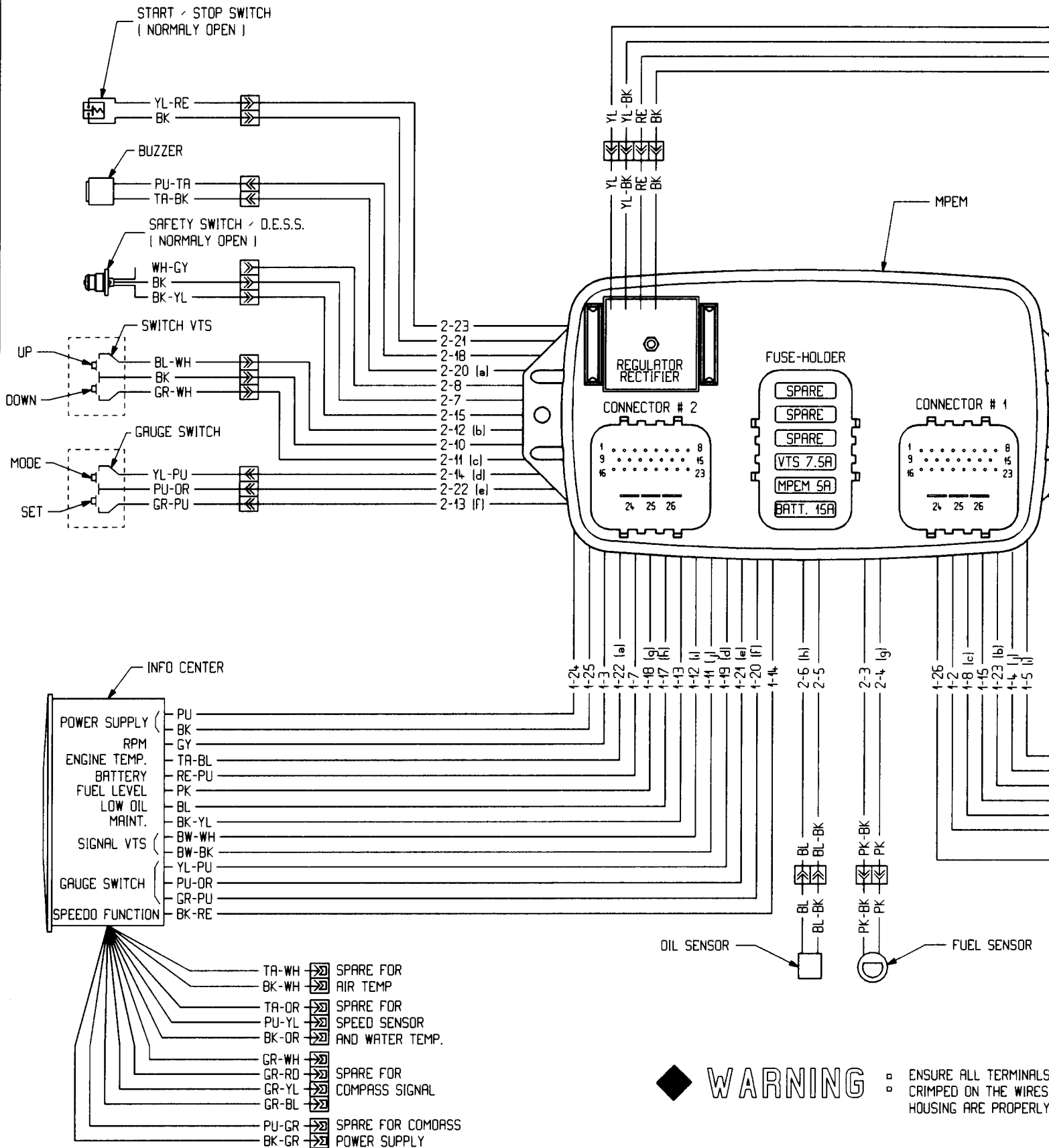

WARNING ■ ENSURE ALL TERMINALS CRIMPED ON THE WIRES HOUSING ARE PROPERLY

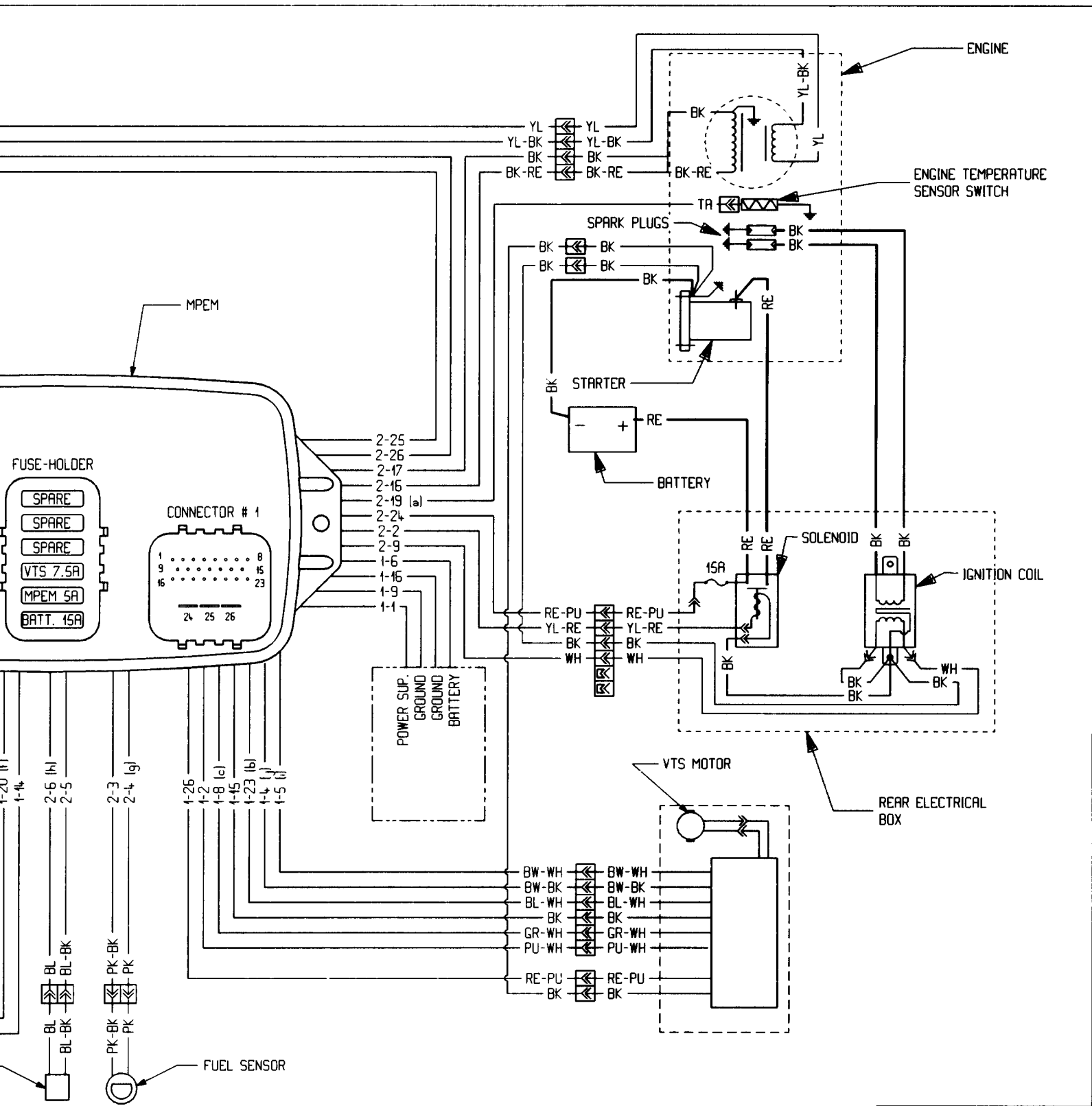

WARNING

- ENSURE ALL TERMINALS ARE PROPERLY CRIMPED ON THE WIRES AND ALL CONNECTOR HOUSING ARE PROPERLY FASTENED.

COLOR CODE	
WH = WHITE	BK = BLACK
RE = RED	YL = YELLOW
PU = PURPLE	TA = TAN
GR = GREEN	BW = BROWN
GY = GREY	BL = BLUE
PK = PINK	OR = ORANGE

GSX MODEL

5624

MODEL GSX '97

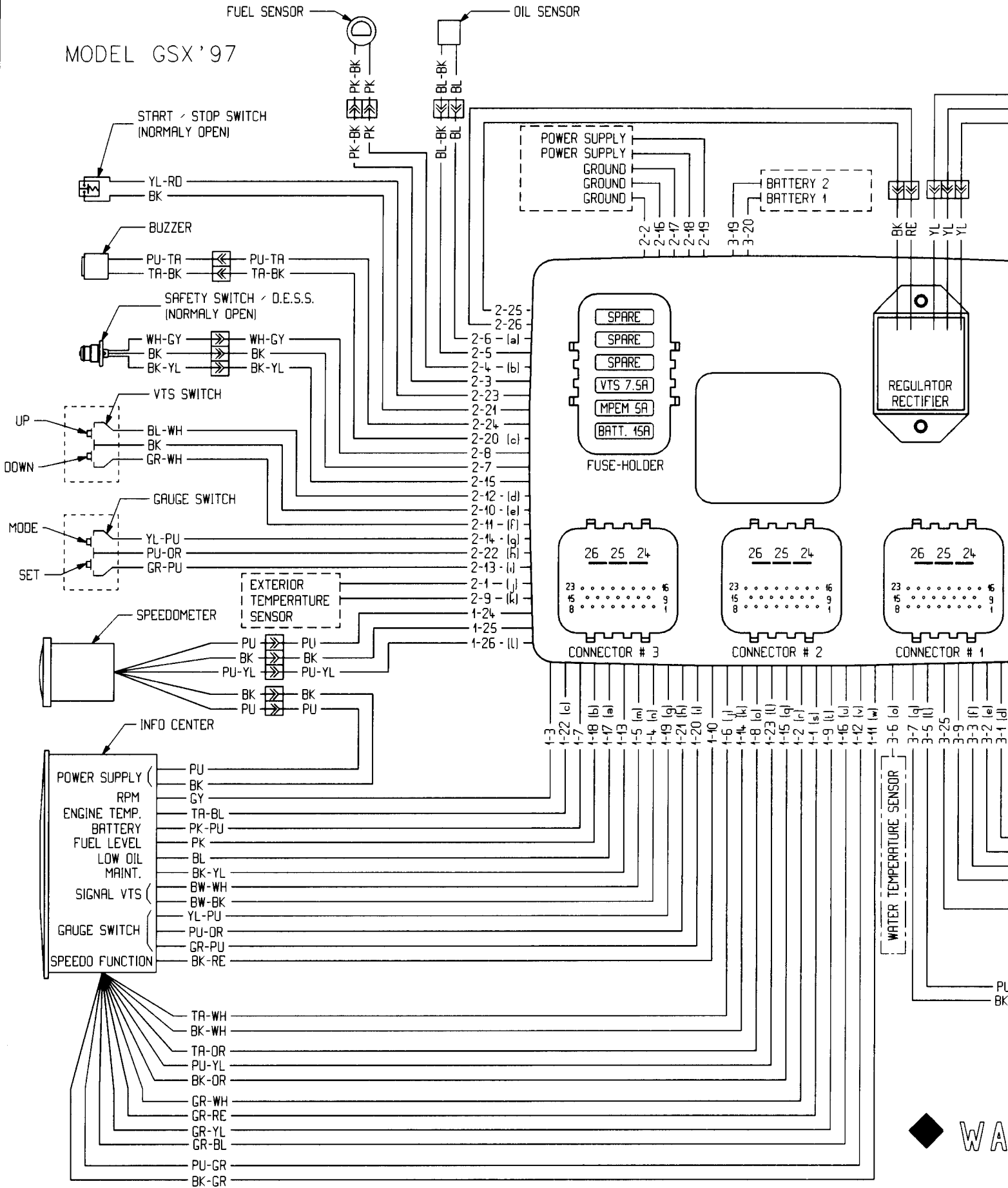

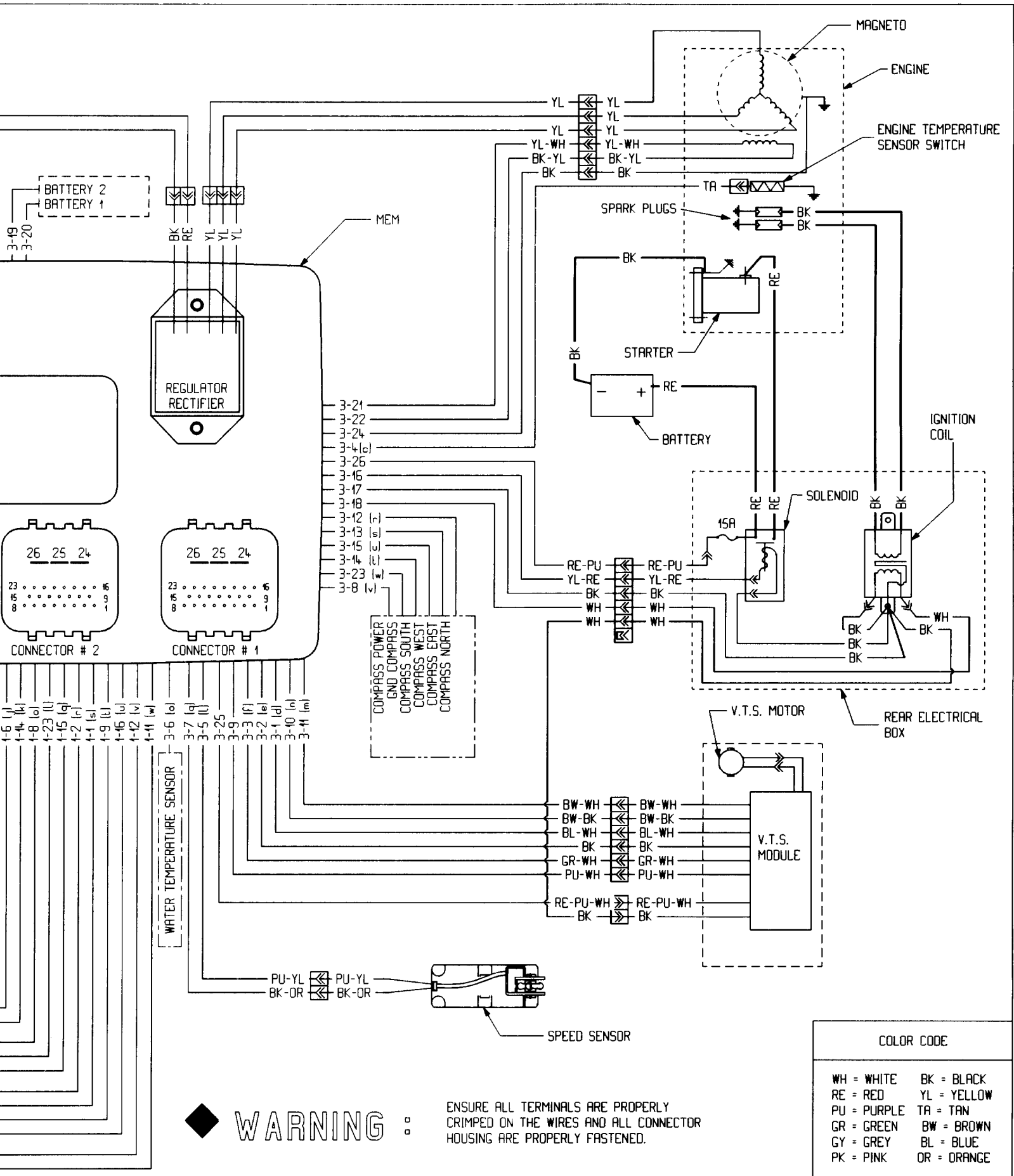

WARNING

ENSURE ALL TERMINALS ARE PROPERLY CRIMPED ON THE WIRES AND ALL CONNECTOR HOUSING ARE PROPERLY FASTENED.

COLOR CODE	
WH = WHITE	BK = BLACK
RE = RED	YL = YELLOW
PU = PURPLE	TA = TAN
GR = GREEN	BW = BROWN
GY = GREY	BL = BLUE
PK = PINK	OR = ORANGE

GTS MODEL

5818

MODEL GTS '97

RECTIFIER

IGNITION C

SWITCH STOP / START
(NORMALLY OPEN)

BUZZER

SAFETY SWITCH / ANTITHEFT
(NORMALLY OPEN)

OIL / FUEL GAUGE

OIL SENSOR

FUEL SENSOR

ELECTRICAL
BOX COVER

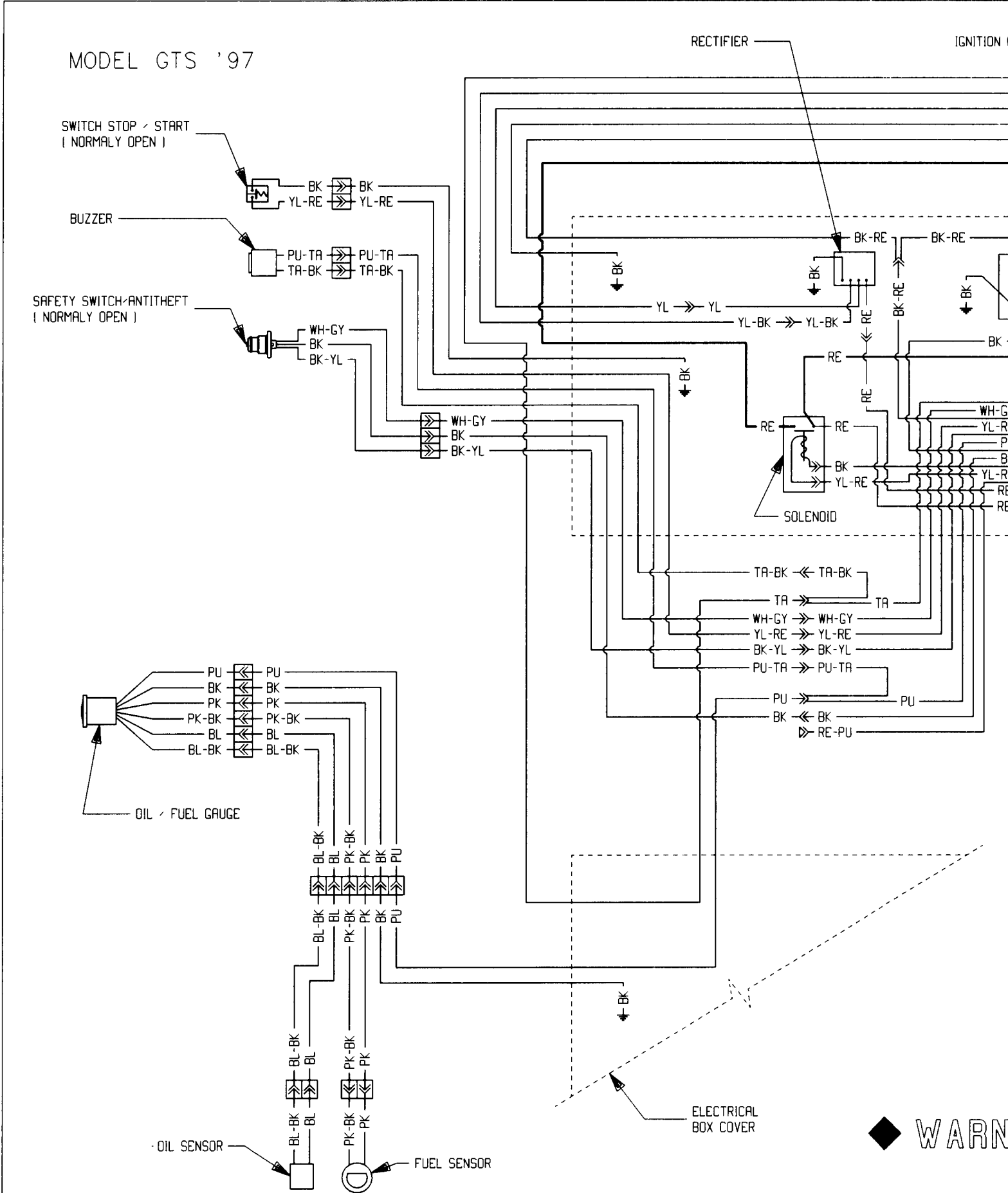

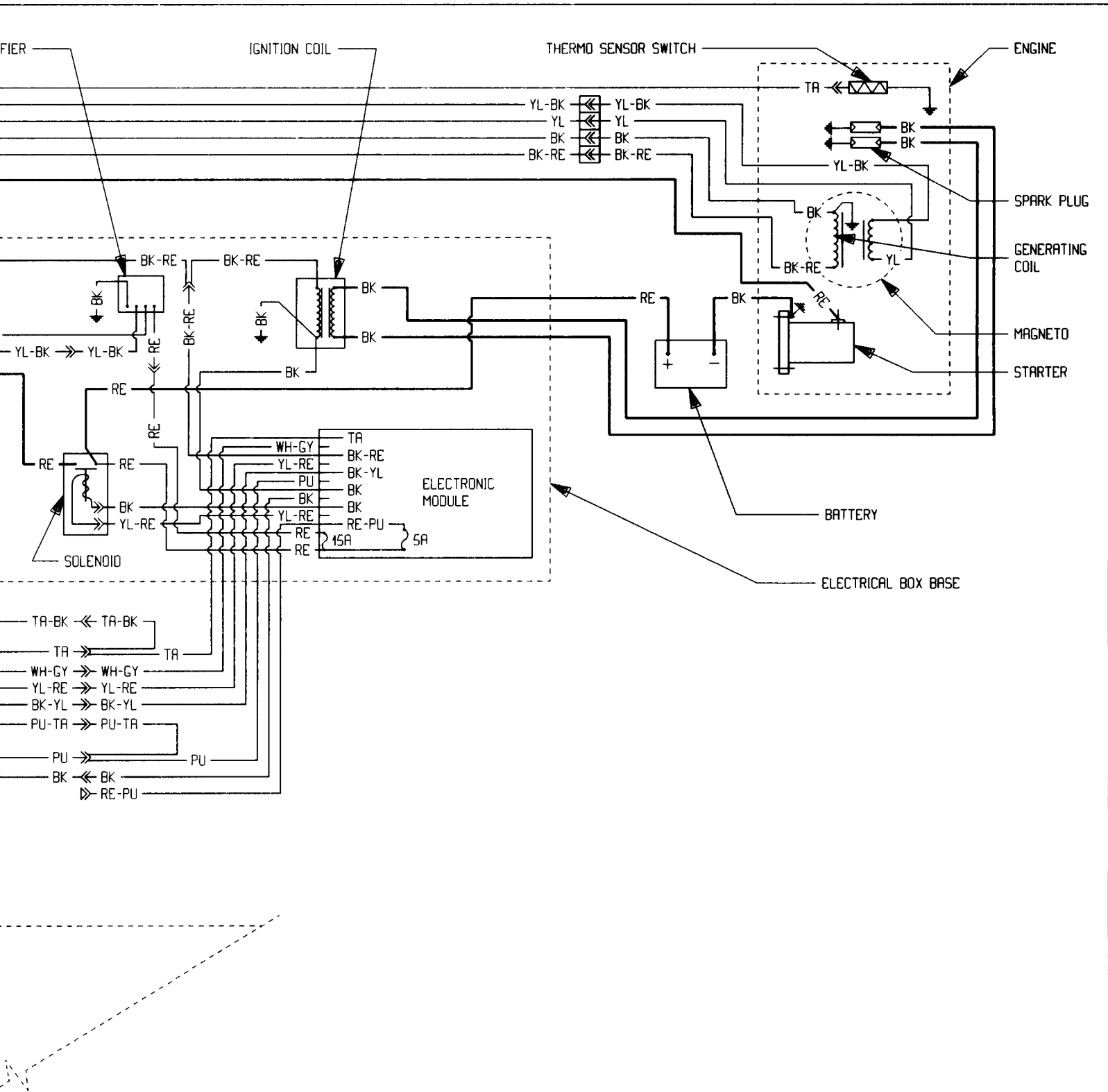

TRICAL
COVER



WARNING

- ENSURE ALL TERMINALS ARE PROPERLY CRIMPED ON THE WIRES AND ALL CONNECTOR HOUSING ARE PROPERLY FASTENED.

COLOR CODE

WH = WHITE	BK = BLACK
RE = RED	YL = YELLOW
PU = PURPLE	TA = TAN
GY = GREY	BL = BLUE
PK = PINK	

GTI MODEL 5641

MODEL GTI '97

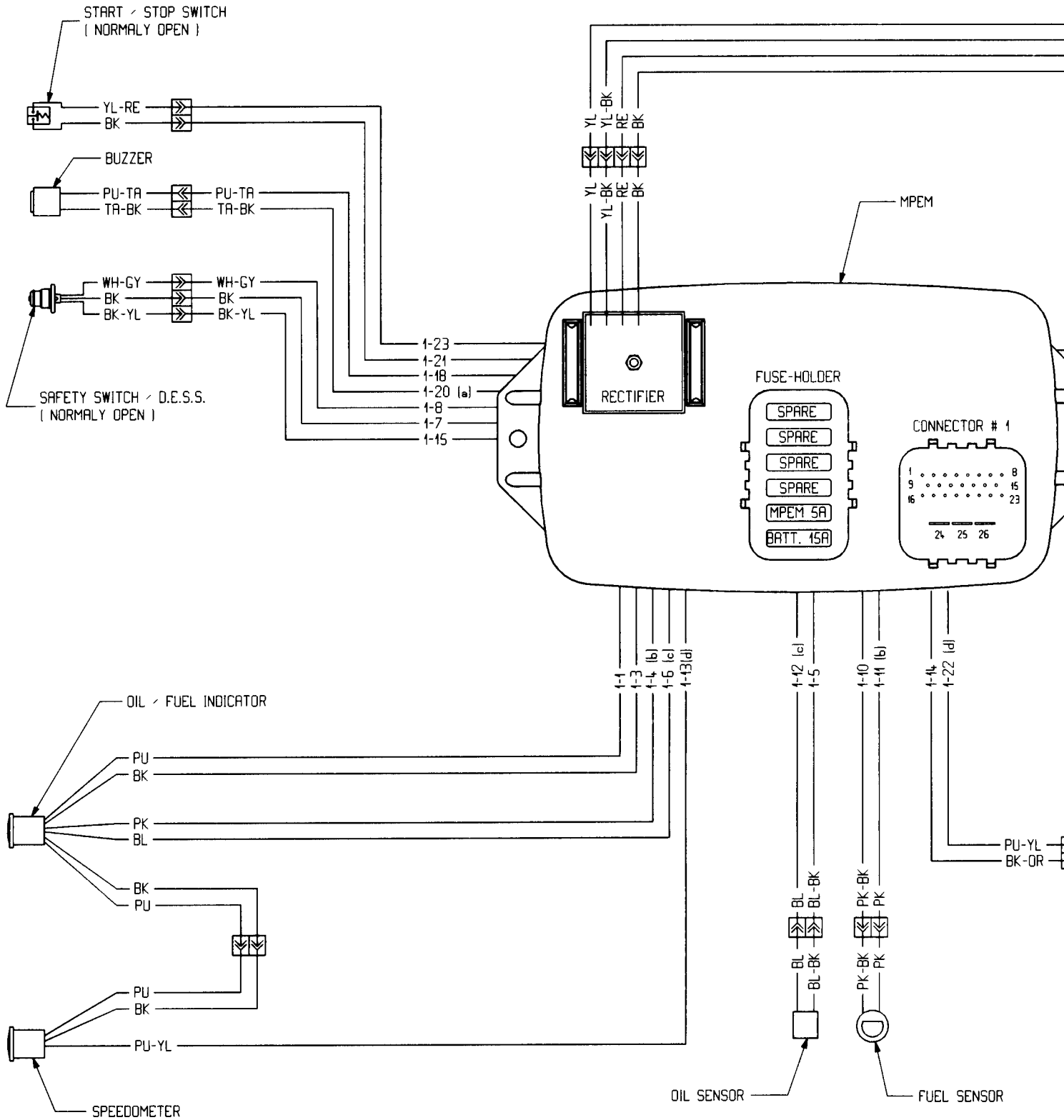

◆ **WARN**

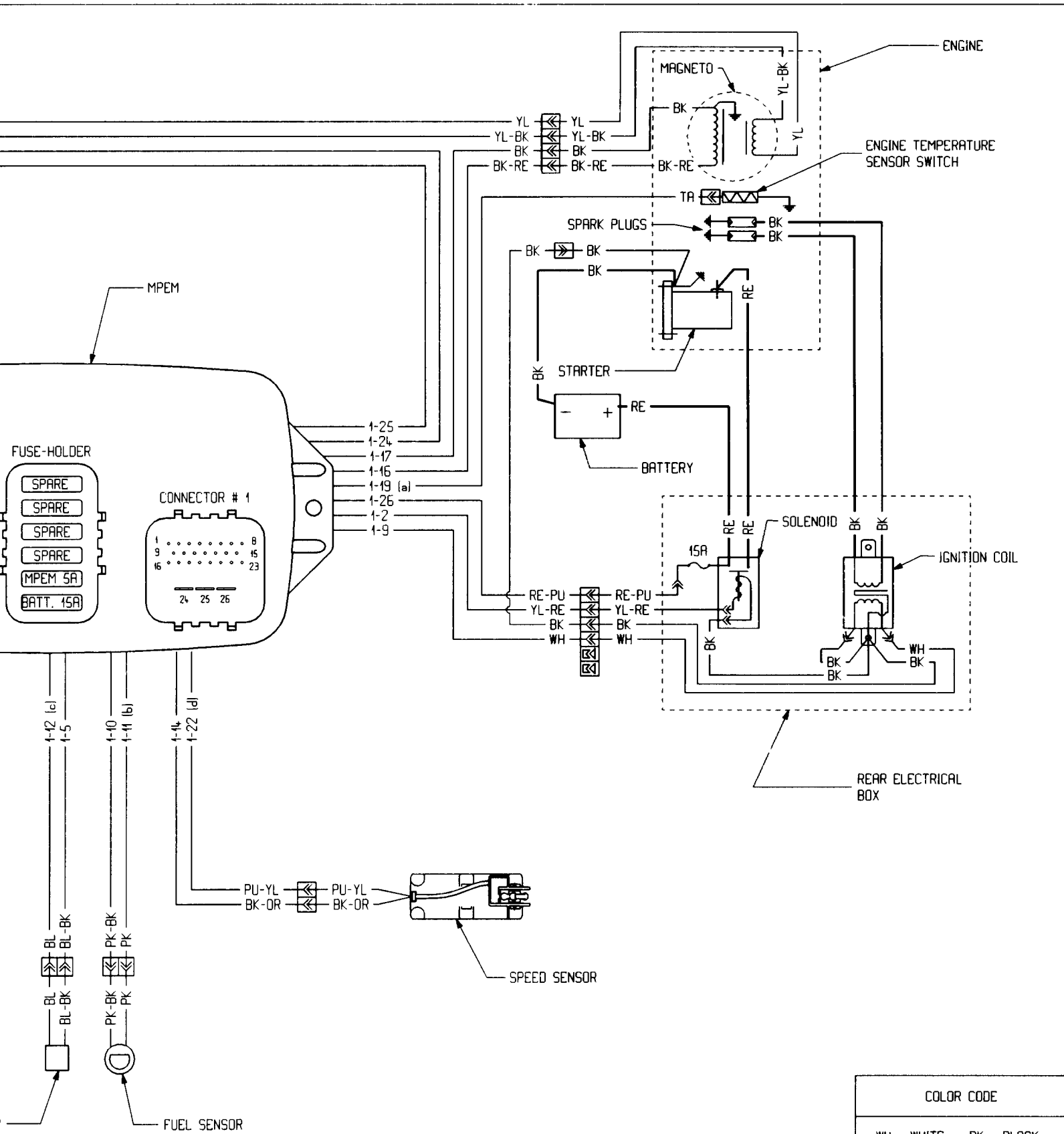

WARNING

- o ENSURE ALL TERMINALS ARE PROPERLY CRIMPED ON THE WIRES AND ALL CONNECTOR HOUSING ARE PROPERLY FASTENED.

COLOR CODE	
WH = WHITE	BK = BLACK
RE = RED	YL = YELLOW
PU = PURPLE	TA = TAN
GR = GREEN	BW = BROWN
GY = GREY	BL = BLUE
PK = PINK	OR = ORANGE

5642

GTX MODEL

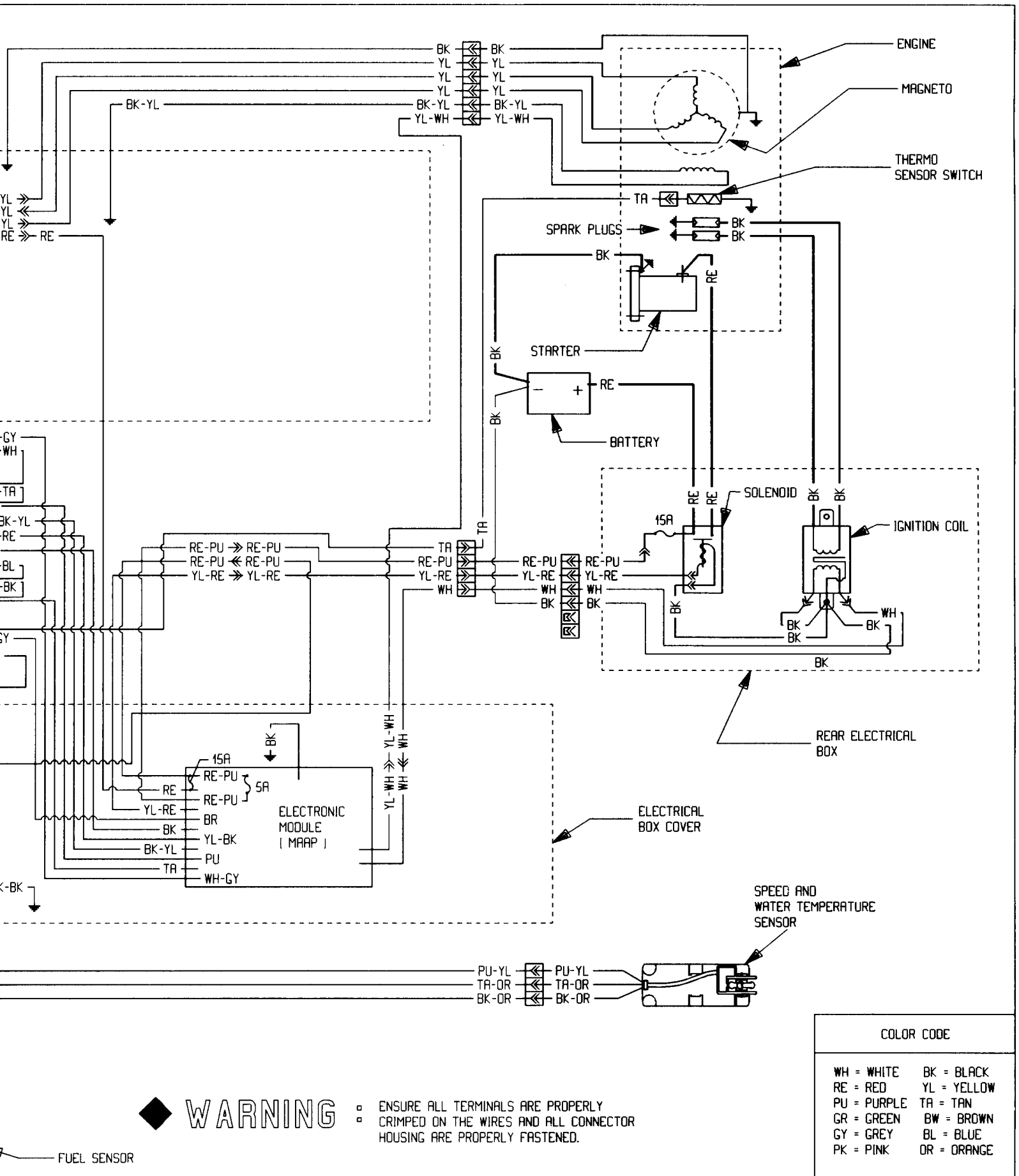

WARNING

- ENSURE ALL TERMINALS ARE PROPERLY CRIMPED ON THE WIRES AND ALL CONNECTOR HOUSING ARE PROPERLY FASTENED.

COLOR CODE	
WH = WHITE	BK = BLACK
RE = RED	YL = YELLOW
PU = PURPLE	TA = TAN
GR = GREEN	BW = BROWN
GY = GREY	BL = BLUE
PK = PINK	OR = ORANGE

XP MODEL

5662

MODEL XP '97

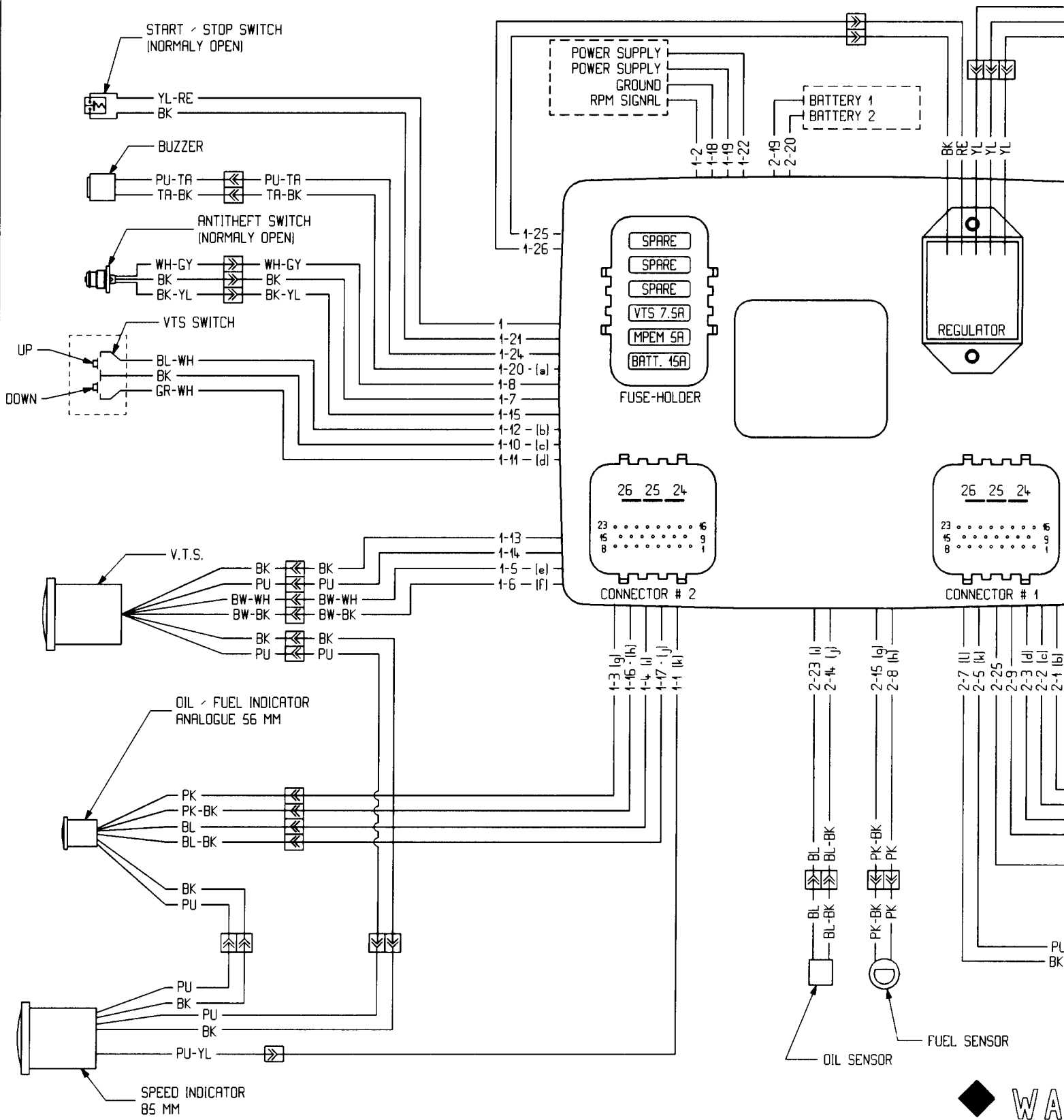

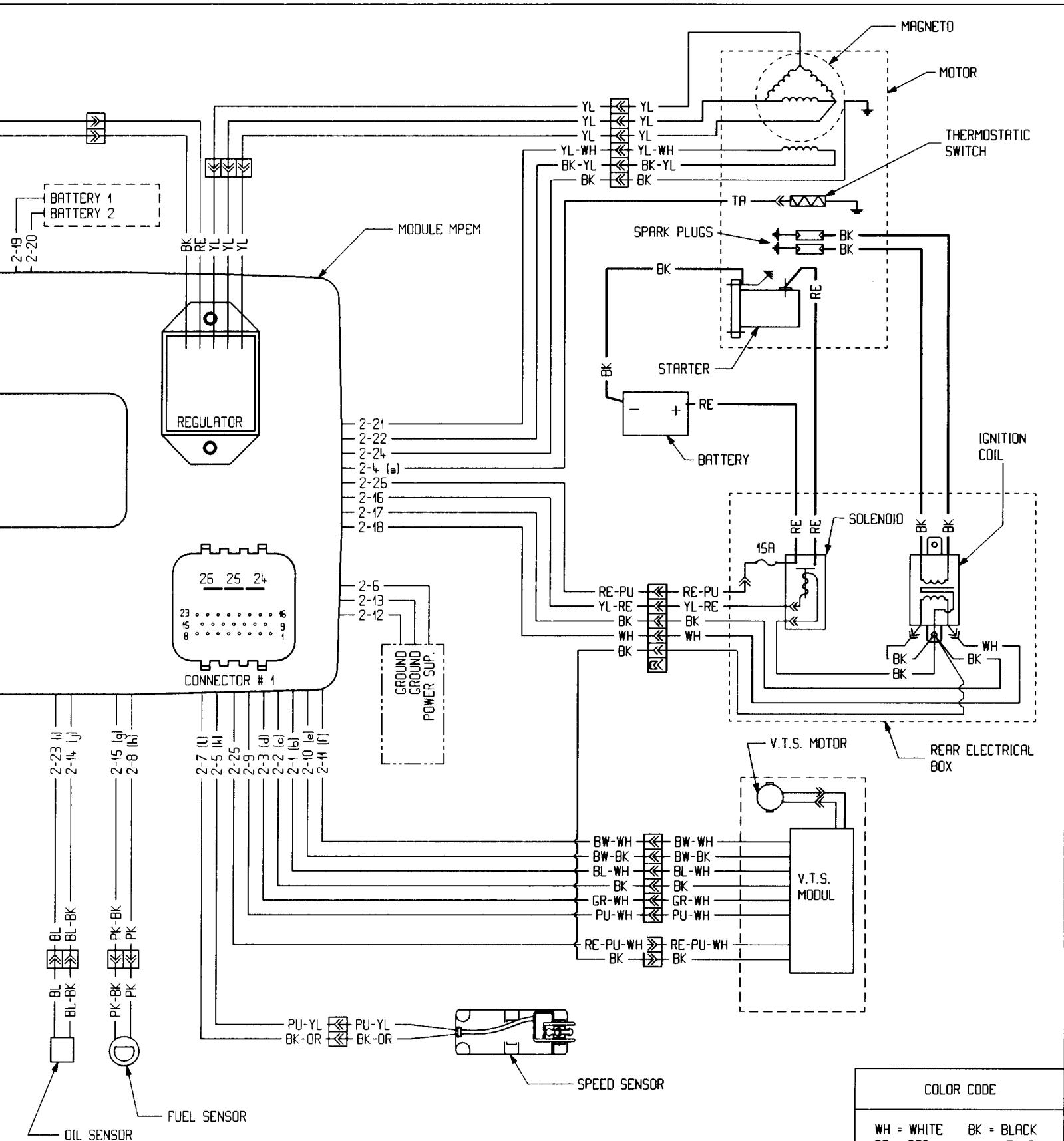

WARNING ◻ ◻

ENSURE ALL TERMINALS ARE PROPERLY CRIMPED ON THE WIRES AND ALL CONNECTOR HOUSING ARE PROPERLY FASTENED.

COLOR CODE	
WH = WHITE	BK = BLACK
RE = RED	YL = YELLOW
PU = PURPLE	TA = TAN
GR = GREEN	BW = BROWN
GY = GREY	BL = BLUE
PK = PINK	OR = ORANGE

HX MODEL 5882

MODEL HX '97

RECTIFIER

IGNITION COIL

SWITCH STOP / START
(NORMALLY OPEN)

BUZZER

SAFETY SWITCH
(NORMALLY OPEN)

OIL / FUEL GAUGE

OIL SENSOR

FUEL SENSOR

ELECTRICAL
BOX COVER

◆ **WARN**

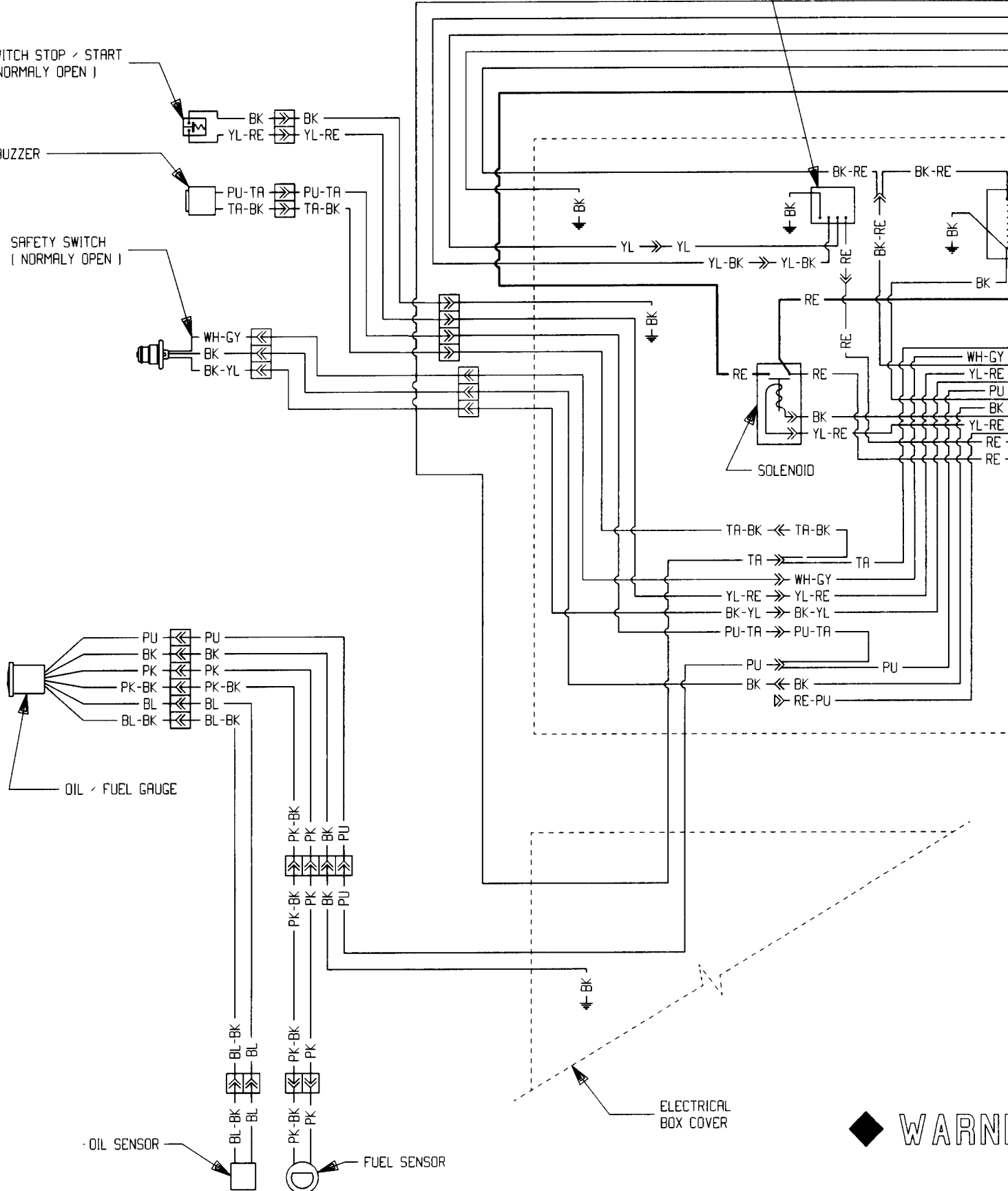

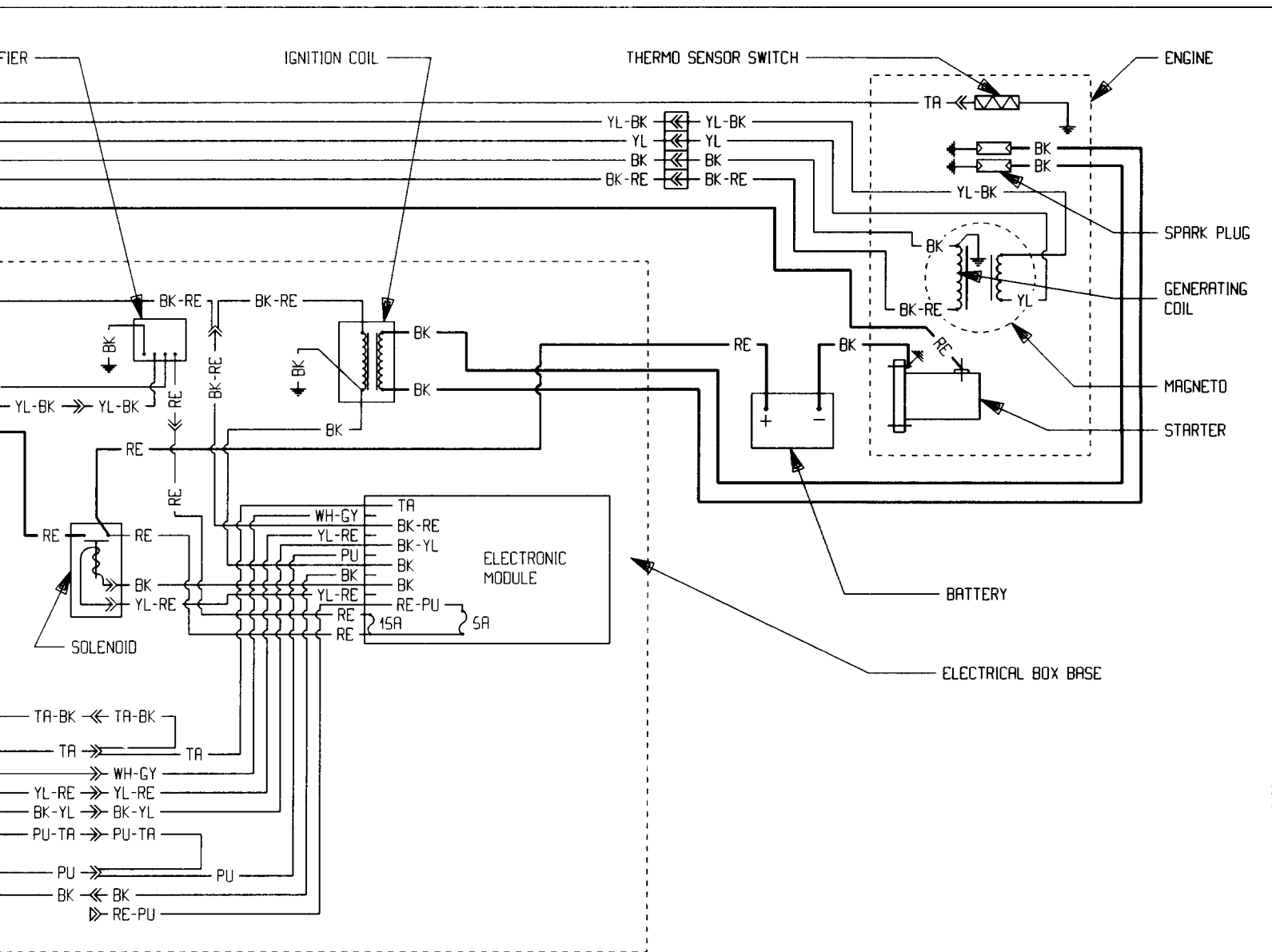

WARNING

- ENSURE ALL TERMINALS ARE PROPERLY CRIMPED ON THE WIRES AND ALL CONNECTOR HOUSING ARE PROPERLY FASTENED.

COLOR CODE	
WH = WHITE	BK = BLACK
RE = RED	YL = YELLOW
PU = PURPLE	TA = TAN
GY = GREY	BL = BLUE
PK = PINK	